



United Nations  
Educational, Scientific and  
Cultural Organization



International  
Hydrological Programme  
of UNESCO

# Practices and experiences of water and wastewater technology

*Proceedings of the Seminar organized by the Regional Centre  
on Urban Water Management (RCUWM-Tehran)*

5-7 October 2004  
Muscat, Sultanate of Oman

**Published in 2006 by the International Hydrological Programme (IHP) of the  
United Nations Educational, Scientific and Cultural Organization (UNESCO)**  
1 rue Miollis, 75732 Paris Cedex 15, France

**IHP-VI Technical Document in Hydrology N°79  
UNESCO Working Series SC-2006/WS/13**

© UNESCO/IHP 2006

The designations employed and the presentation of material throughout the publication do not imply the expression of any opinion whatsoever on the part of UNESCO concerning the legal status of any country, territory, city or of its authorities, or concerning the delimitation of its frontiers or boundaries.

This publication may be reproduced in whole or in part in any form for education or nonprofit use, without special permission from the copyright holder, provided acknowledgement of the source is made. As a courtesy the authors should be informed of any use made of their work. No use of this publication may be made for commercial purposes.

Publications in the series of *IHP Technical Documents in Hydrology* are available from:

IHP Secretariat | UNESCO | Division of Water Sciences  
1 rue Miollis, 75732 Paris Cedex 15, France  
Tel: +33 (0)1 45 68 40 01 | Fax: +33 (0)1 45 68 58 11  
E-mail: [ihp@unesco.org](mailto:ihp@unesco.org)  
<http://www.unesco.org/water/ihp>

## PREFACE

The 21<sup>st</sup> century could be considered as an urbanizing century. According to statistics, by the year 2020 almost 60 percent of the world's population will be settled in urban areas. This trend is already apparent in some countries like Iran, and is predicted to further increase over the next 15 years.

Yet population growth in urban areas results in increased water demands. Finite water resources and difficulties in managing water and wastewater lead to the three following types of challenges:

- Social challenges: the need for fair water allocation in different sectors, sustainable and reliable water supply and water conveyance for the population, and the creation of facilities to hygienically dispose of wastewater, particularly in poor residential urban areas;
- Environmental challenges: the need to deal with increases in urban wastewater; and
- Financial challenges: the need to meet expenses for water supply and water treatment.

Overcome these challenges, providing suitable action plans - and thereby achieving the Millennium Development Goals and those of the Johannesburg World Summit on Sustainable Development (2002) - requires extensive activities at the national, international and regional levels.

Already, political and civil societies have increasingly expressed concern about and interest in water-related problems and water management. Commitment and activism has been demonstrated by the UN entitling the decade from 2005 to 2015 as "Water for Life", as well as through regional solutions, plans and conferences, such as "Water for African Cities" and "Water for Asian Cities". Efficient cooperation is required for the execution phase of these plans, and, together with other local and civil society initiatives, they constitute high priorities in addressing today's water and wastewater related challenges.

It is expected that continuing to hold regionally-based seminars will provide a positive way forward. Seminars help to focus on regionally important problems and identify deficiencies, potential risks and threats associated with current means of water and wastewater management, while also enabling participants to suggest realistic solutions.

Water is a finite yet important resource, the cornerstone of sustainable development in urban areas, and vital to economic and social development. I believe that, in order to promote it as such, the following points should be considered in executive and operational policies and plans:

- Methods of integrated water resources management in urban areas that take into account social, environmental and economic constraints;
- Harmony between programming and executing regulations relating to urban development and water resources planning and management;
- Consideration of demand management as a priority strategy in urban water management planning;
- Support of technology propagation in order to reduce wastewater in urban water distribution systems, water harvesting in urban areas and reusing wastewater, for example;
- Promotion of good governance in urban water management;
- Promotion of supply methods for financial recourses through modern approaches and water pricing.

Undoubtedly, concentrating on such approaches will help secure the sustainability of international cooperation between different countries in the region.

I hope that these suggestions, along with the other key notes that are exchanged during this seminar, particularly those valuable papers which are presented, as well as the outcomes of the seminar, will be helpful for decision makers, experts and those involved in urban water management in the region.

The Regional Centre on Urban Water Management (RCUWM – Tehran) hereby declares its intention and preparedness to follow relevant suggestions and recommendations in this respect.

I also wish to express my sincere appreciation and acknowledgement of our partners from the Ministry of Municipalities, Environment and Water Resources, Sultanate of Oman and the Federal Ministry of Education and Research, Germany - both of whom are respectful members of the Governing Board of the Centre - due to their efforts in organizing such a fruitful event as this in Muscat, Oman.

Reza Ardakanian, Director  
Regional Centre on Urban Water Management – Tehran

Address: No. 120, Khoramshahr St., Tehran, 1553713511, Iran  
Tel: +98 21 88 75 49 36  
Fax: +98 21 88 74 12 30  
Email: [info@rcuwm.org.ir](mailto:info@rcuwm.org.ir)  
Website: [www.rcuwm.org.ir](http://www.rcuwm.org.ir)

## TABLE OF CONTENTS

Preface	i
Desalination in Oman and the Fundamentals of Reverse Osmosis design <i>Ahmed Al-Busaidi</i>	1
Quality Aspects Of Reclaimed Domestic Wastewater In Jordan <i>Uleimat, Ahmed Ali</i>	15
Data and Information Management for Capacity Building of the Water Resources Sector in Indonesia <i>M. A. Fulazzak, H. Akil</i>	26
Evaluation of the Performance of Carbon Dioxide Removal Processes in Reverse Osmosis Desalination Systems <i>Professor Dr. Alaa' Abdulrazaq Jassim; Professor Dr. Saleh Ismial, Mahmood Shaker</i>	35
Water Reuse: An Overview <i>Prof. Dr.-Ing. Peter Cornel and Dipl.-Ing.Barbara Weber</i>	38
Measures to Minimize Water Consumption and Water Losses - Case Study Of Berlin <i>Bernd Heinzmann</i>	48
Middle East Desalination Research Centre: A Contribution to Desalination Research and Development <i>Kandi Venkat Reddy and Mousa K. Abu Arabi</i>	58
Wastewater Management in Urban and Rural Areas: A Review of The Islamic Republic Of Iran's Experiences <i>Seyed Ali Mahmoudian</i>	75
Supply and Consumption Management in Megacities: Experiences of theMegacity of Tehran <i>Sattar Mahmoudi</i>	92
Training And Capacity Building In Water And Water Technology In Egypt <i>Mohamed B. Abdel Ghany, Dalal S. Alnaggar</i>	102
Public Education: An Effective Water Demand Management Strategy <i>Niaz Mazaraa</i>	117
Refinery Wastewater Treatment By Microfiltration And Ultrafiltration Membranes <i>Noredine Ghaffour1, Jean Luc Negrel andRahim Jassim</i>	122
Wastewater Technology In Yemen <i>Dr. Fadhl Ali Al-Nozaily</i>	133
Overcoming Constraints In Treated Greywater Reuse In Oman <i>SA Prathapar, A.Jamrah, M Ahmed, S Al Adawi, S Al Sidair and A Al Harassi</i>	138
Desalination Privatization In The Sultanate Of Oman Case Study: Barka Power and Desalination Plant <i>Taher M. Ali Sajwani andAhmed Al Subhi</i>	148

Decentralized Wastewater Use For Urban Agriculture In Peri-Urban Areas: An Imminent Option For The Organisation Of Islamic Conference Countries <i>Al-Beirut, Shihab N.</i>	151
Use Of Pyroaurite Type Sorbent, Activated Carbon And Flyash In Reducing Cod Of Domestic Wastewater Dr R.P. Singh, Piyush Gupta, Namrata Gupta and Radha Gupta	160
Removal Of Heavy Metals From Electroplating Effluents By Carbonized Agrowastes <i>R.P Singh, N. Gupta, R. Suman and Radha Gupta</i>	167
Ash'sharqiyah Sands Water Supply Scheme <i>Eng. Zaher Bin Khalid Al Sulaimani, Eng. Said Bin Khamis Al Khamisi, Dr. Ali Gharbi, Eng. Ziad Al Aswad</i>	174
Fayoum City Sewage Treatment Plant, Development Stages, Case Study <i>Ahmed El-Zayat</i>	189

# DESALINATION IN OMAN AND THE FUNDAMENTALS OF REVERSE OSMOSIS DESIGN

Ahmed Al-Busaidi

Ministry of Housing, Electricity and Water, Sultanate of Oman

Tel: +968 699177, Fax: +968 607076, Email: abusaidi@omantel.net.om

## ABSTRACT

Desalination is the process of exploitation of non-conventional water resources. In Oman, over the last 10 years there has been a wide increase in the number of the water desalination plants which utilise a distillation process and reverse osmosis membrane technology for the production of potable water. Oman has experience with both water desalination from a sea water intake system and brackish water. The Al-Gubrah (MSF) and Sur (RO) plants are the largest plants of their kind, with a total production capacity of 42 and 1.660 million gallons per day respectively. Examining this desalination experience comprises the first part of this paper. The second part of the paper presents the fundamentals of the reverse osmosis desalination plants' design, including the design features and the operating parameters an existing RO plants in Oman.

*Keywords: Desalination-Oman; Reverse Osmosis; RO plant design, RO Performance Parameters.*

## INTRODUCTION

Oman is located in the south-east part of the Arabian peninsular. Particularly during the last 10 to 15 years, it has experienced a substantial increase in water demands due to the deterioration of ground water and a decrease in rainfall, precipitating an increase in the number and size of the water desalination plants. In this regard, both the distillation process and the reverse osmosis (RO) membrane technology have been used in Oman for the production of potable water.

Several RO desalination plants have been constructed for the production of drinking water in the regional areas of Oman. Here, plant design has been of primary importance, in terms of its efficiency, limited or reduced installation and operation costs, and the extent to which it makes water publicly available. Implementing reverse osmosis processes therefore greatly depends on these fundamentals of design. Further details of implementation of desalination initiatives are explained in more detail below.

## OMAN'S EXPERIENCE IN DESALINATION

Due to the per capita increase in water demand, the expansion of industrial activities and the development of tourism, desalination became the best solution for the production of fresh water. Since 1976, in facing the problem of water needs in Oman and seeking to overcome water shortages amplified by the demographics of the region, several desalination plants were constructed for the production of drinking water for domestic and industrial use from brackish and sea water.

### Oman's desalination production capacity

The production capacity of water in Oman reached over 64 million GDP as at 2003, as shown in Figure 1 (below). Of this, 95 percent of the water was produced for sea water distillation process (MSF) and the rest from Reverse osmosis membrane technology, including 0.022 million GDP produced by an electro dialysis (ED) plant constructed 1982. The desalinated water salinity in Oman ranges from 2500 to 17000 PPM for brackish water, and the salinity range from sea water is between 32,000 and 40,000 PPM.

Figure 1: Oman's desalination production capacity 1967-2003

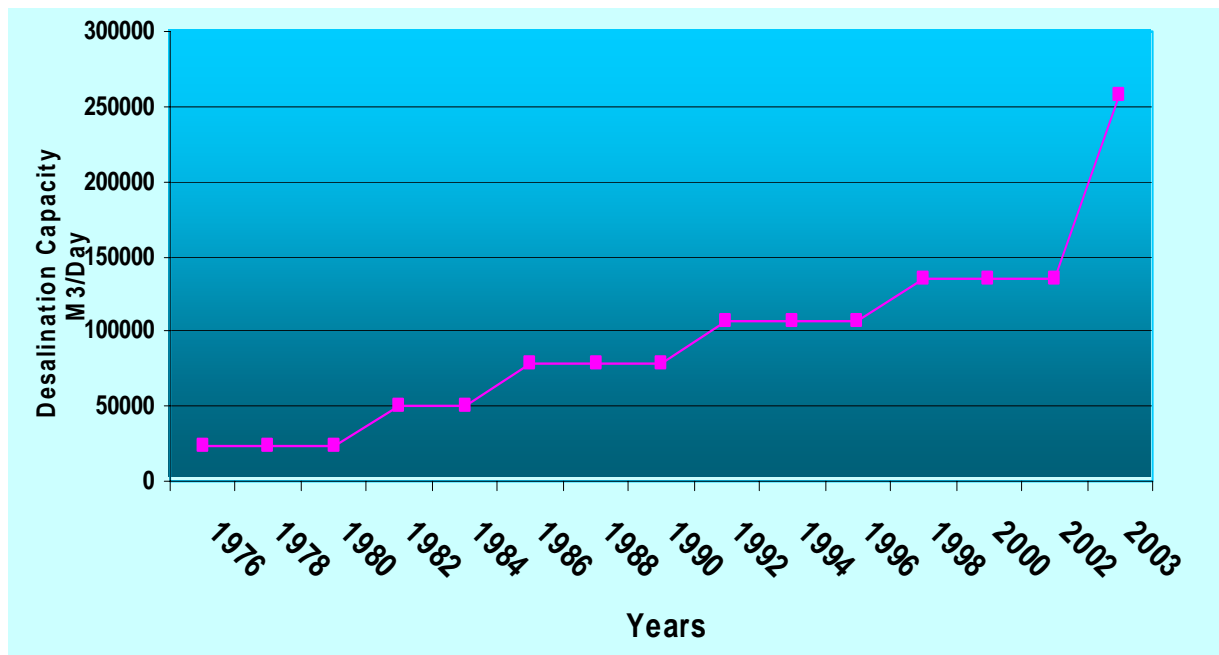

### Typical sea water chemical analysis in Oman

The chemical composition of Oman sea water is almost constant, however the total amount of dissolved solids changes subject to local conditions. Table 1 (below) shows the typical composition of sea water in Oman, which has salinity of 34,775 PPM.



Table 1: Typical composition of sea water in Oman - Source location Sur- dated March 2004

ITEM	UNIT	CONCENTRATION
Color	Pt/Co Scale	1
Odour		Odourless
Taste		Salty
Turbidity	NTU	0.09
Temperature	°C	23.5
pH		7.31
Electrical Conductivity at 25 °C	Us/cm	53500
Total Dissolved Solids (TDS)	Mg/L	34775
Phenolphthalein Alkalinity as CaCO <sub>3</sub>	Mg/L	0.0
Methyl Orange Alkalinity as CaCO <sub>3</sub>	Mg/L	109
Bicarbonate Alkalinity as CaCO <sub>3</sub>	Mg/L	109
Carbonate Alkalinity as CaCO <sub>3</sub>	Mg/L	0.0
Hydroxide Alkalinity as CaCO <sub>3</sub>	Mg/L	0.0
Chloride as Cl	Mg/L	22481
Total Hardness as CaCO <sub>3</sub>	Mg/L	7360
Calcium as Ca <sup>++</sup>	Mg/L	840
Magnesium as Mg <sup>++</sup>	Mg/L	1262
Carbonate Hardness as CaCO <sub>3</sub>	Mg/L	109
Non-Carbonate Hardness as CaCO <sub>3</sub>	Mg/L	7250
Langelier Index	Mg/L	-
Total Iron as Fe <sup>++</sup>	Mg/L	0.462
Phosphate as PO <sub>4</sub> <sup>-</sup>	Mg/L	-
Nitrate as NO <sub>3</sub> <sup>-</sup>	Mg/L	>0.2
Fluoride as F	Mg/L	0.65
Free Residual Chlorine as Cl <sub>2</sub>	Mg/L	0
Copper as Cu <sup>++</sup>	Mg/L	-
Sulphate as So <sub>4</sub> <sup>-</sup>	Mg/L	1657.3
Potassium as K <sup>+</sup>	Mg/L	435.0
Sodium as Na <sup>+</sup>	Mg/L	11600.0
Phenolic Compounds as PHENOL	Mg/L	-
Dissolved Oxygen as O <sub>2</sub>	Mg/L	4.28

## FUNDAMENTALS OF REVERSE OSMOSIS DESIGN

### Principle of reverse osmosis

The process of osmosis is illustrated in Figure 2 (below). A semi-permeable membrane is placed between two compartments. In this configuration, the direction of solvent flow is determined by its chemical potential, which is a function of pressure, temperature and concentration of dissolved solids. Pure water, in contact with both sides of an ideal semi-permeable membrane at equal pressure and temperature, has no net flow across the membrane because the chemical potential is equal on both sides. If a soluble salt is added on one side, the chemical potential of this salt solution is reduced. Osmotic flow from the pure water side across the membrane to the salt solution side will occur until the equilibrium of chemical potential is restored. Equilibrium occurs when the hydrostatic pressure differential resulting from the volume changes on both sides is equal to the osmotic pressure. Application of an external high pressure to the salt solution side will raise the chemical potential of the water in the salt solution and cause a solvent flow to the pure water side.

**Figure2: Osmosis and reverse osmosis processes**

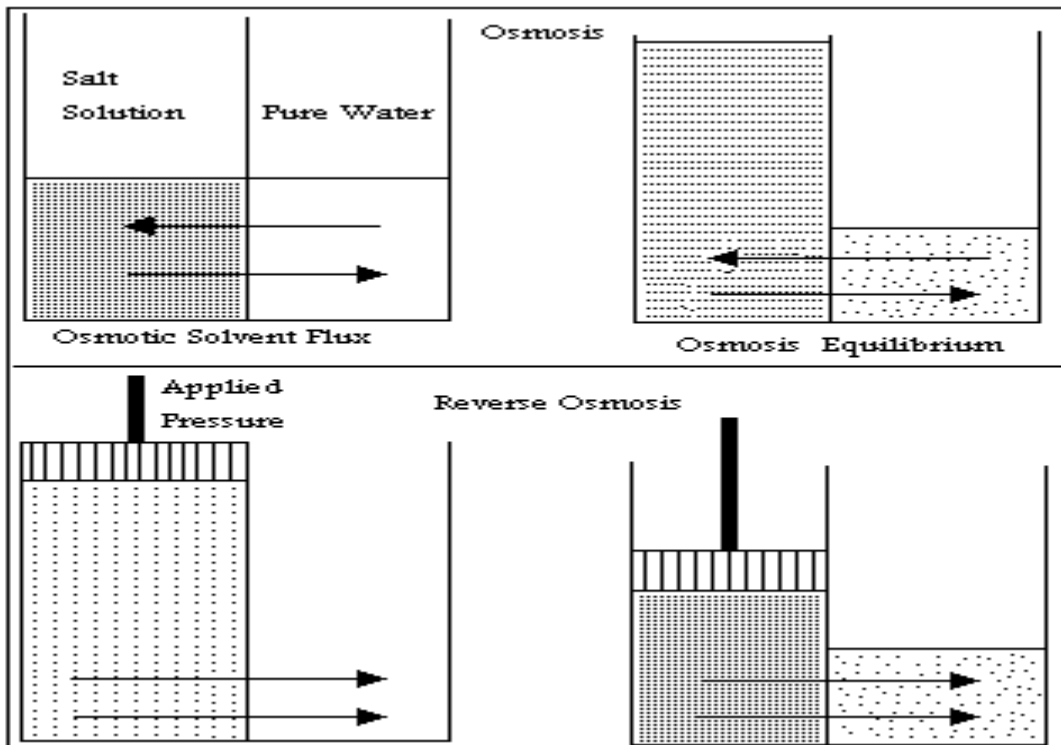

**Reverse osmosis process description**

With a high pressure pump, pressurized saline feed water is continuously pumped to the module system. Within the module, consisting of a pressure vessel and a membrane element, the feed water will be split into a low saline product, called permeate and a high saline brine, called reject. A flow-regulating valve, called a concentrate valve, controls the percentage of feed water that is going to the concentrate stream and the permeate which will be obtained from the feed.

The flow diagram depicted in Figure 3 (below) shows the flow of the pressurized water into the membrane vessel (in the case of a spiral wound module) and through the channels between the spiral windings of the elements. The feed water flows from one element to the other and exits into the concentrate valve, where the applied pressure will be released, and the water produced will be collected from the permeate tube installed in the center of each spiral wound element.

**Figure 3: Reverse osmosis process**

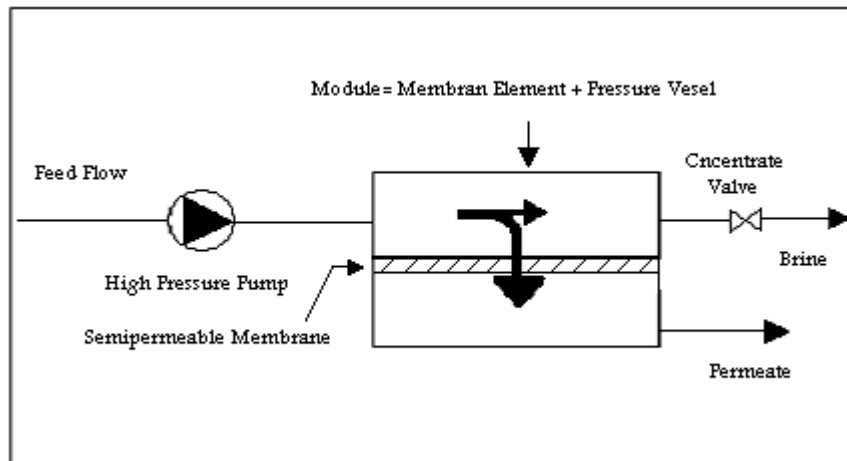

### **Reverse osmosis membranes**

Membrane performance tends to deteriorate over time due to fouling. Although membrane longevity has improved, it is still relatively short (typically three to five years although some are used for much longer). Reverse osmosis membranes are made in a variety of configurations. Two of the most commercially successful are hollow fiber and spiral wound, described in more detail in the following sections.

#### **Hollow fiber**

This configuration uses membrane in the form of hollow fibers, which have been extruded from cellulosic or non-cellulosic materials. The fiber is asymmetric in structure and is as fine as a human hair. Millions of these fibers are formed into a bundle and folded in half to a length of approximately 120 cm. A perforated plastic tube, serving as a feed water distributor, is inserted in the center and extends the full length of the bundle. The bundle is wrapped and both ends are epoxy sealed to form a sheet-like permeate tube end and a terminal end which prevents the feed stream from bypassing to the brine outlet.

#### **Spiral wound**

In the spiral wound configuration (see Figure 4 below), two flat sheets of membrane are separated with a permeate collector channel material to form a leaf. This assembly is sealed on three sides, with the fourth side left open for permeate to exit. A feed/brine spacer material sheet is added to the leaf assembly. A number of these assemblies or leaves are wound around a central plastic permeate tube. This tube is perforated to collect the permeate from the multiple leaf assemblies. The feed/brine flow through the element is straight axial path from the feed end to the opposite brine end, running parallel to the membrane surface.

Figure 4: Spiral wound membrane module

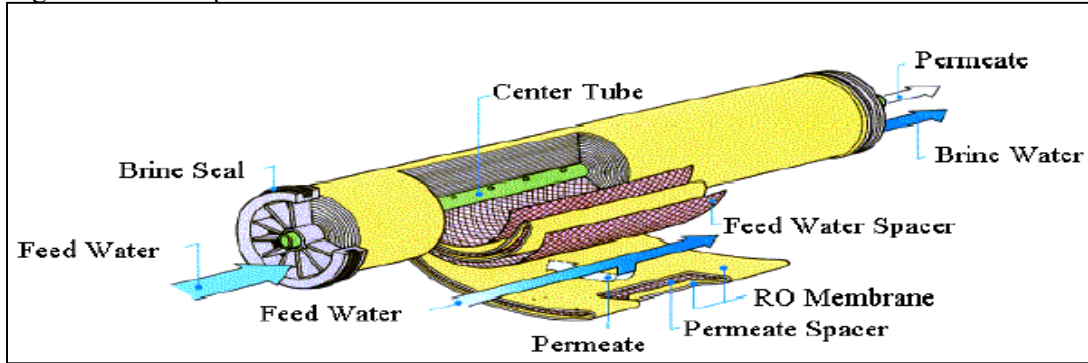

### Reverse osmosis performance parameters

Reverse osmosis is defined in terms of a number of variables, which include: osmotic and operating pressure, salt rejection and permeate recovery. These are described in more detail below.

### Osmotic and operating pressure

The osmotic pressure -  $\pi$  - of a solution can be determined experimentally by measuring the concentration of dissolved salts in the solution. The osmotic pressure is obtained from the following equation:

$$\pi = RT \sum X_i$$

where

$\pi$  is the osmotic pressure (kpa)

T is the temperature (k)

R is the universal gas constant, 8.314 kPa m<sup>3</sup>/kgmol K

$\sum X_i$  is the concentration of all constituents in a solution (kgmol/m<sup>3</sup>)

An approximation for  $\pi$  may be made by assuming that 1000 PPM of total dissolved solids (TDS) equals 75.84 kPa of osmotic pressure.

The operating pressure is adjusted to overcome the adverse effects of osmotic pressure, friction losses, membrane resistance and permeate pressure.

If the operating pressure is set to the sum of the above equation, the net permeate flow rate across the membrane would be minimal or equal to zero; therefore, the operating pressure is set at a higher value in order to maintain an economical permeate flow rate.

## **Salt rejection**

Salt rejection is the opposite of salt passage, and is defined as:

$$SR = 100\% - SP$$

where

SR is the salt rejection (in %) and SP is the salt passage as defined in by:

$$SP = 100 \% * (C_p/C_{avg})$$

where

$C_p$  = salt concentrate in the permeate

$C_{avg}$  = mean salt concentration in the feed stream.

This concentration may be estimated as follows:

$$C_{avg} = (C_f + C_b) / 2$$

where

$C_f$  = Feed concentration

$C_b$  = Brine concentration

## **Permeate recovery rate**

Permeate recovery is another important parameter in the design and operation of RO systems. The recovery rate of feed water to product is defined as:

$$R = 100\% * (Q_p/Q_f)$$

where

R is the Recovery rate (in %),

$Q_p$  is the product water flow rate,

and  $Q_f$  is the feed water flow rate.

## **Factors influencing reverse osmosis performance**

Permeate flux and salt rejection are the key performance parameters of a reverse osmosis process. They are mainly influenced by pressure, temperature, recovery, and feed water salt concentration.

The following graphs show the impact of those parameters when the other three parameters are kept constant. Not to be neglected are several other important factors which cannot be seen directly in membrane performance, namely, the maintenance and operation of the plant and proper pretreatment design. Their impacts are as follows:

- With increasing effective feed pressure, the permeate TDS will decrease while the permeate flux and the salt passage will increase (see Figure 5 below);
- If the temperature increases and all other parameters are kept constant, the permeate flux and the salt passage will increase (see Figure 6 below);

- Increased recovery of the permeate flux will decrease and stop if the salt concentration reaches a value where the osmotic pressure of the concentrate is as high as the applied feed pressure. The salt rejection will drop with increasing recovery (see Figure 7 below);
- The feed water salt concentration will impact the permeate flux and the salt rejection (see Figure 8 below).

Figures 5,6,7,8: Permeate Flux and Salt Rejection – performance vs. variables

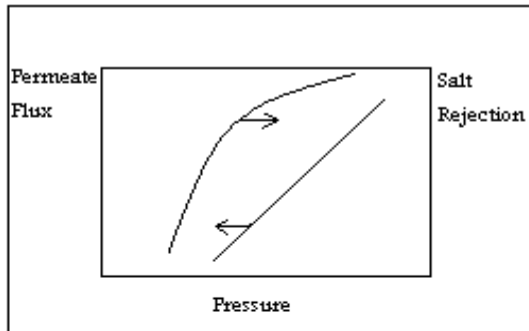

Fig5 Performance vs. Pressure

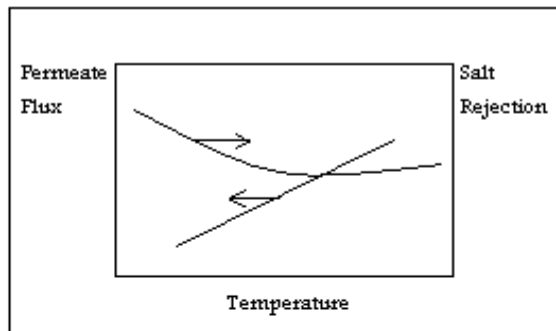

Fig6 Performance vs. Temperature

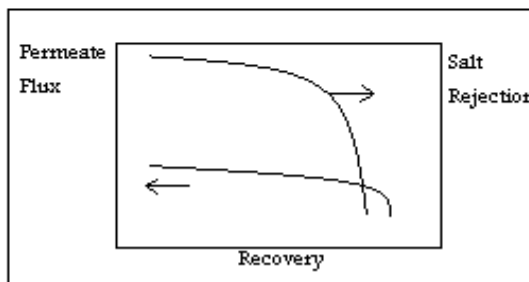

Fig 7 Performance vs. Recovery

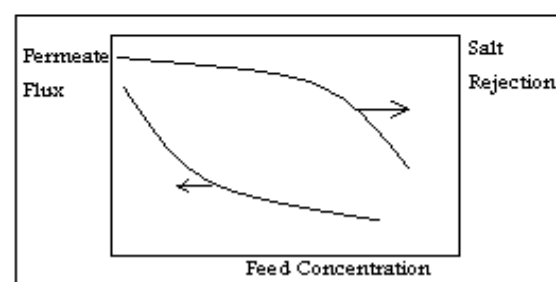

Fig8 Performance vs. Feed water Salt Concentration

## Reverse osmosis and system variables

The reverse osmosis process is defined in terms of a number of variables, including the osmotic pressure, water transport, salt transport, salt rejection, permeate recovery and concentration polarization. Some of these are described in more detail in the following sections.

### Water transport

The rate of water passage through a semi-permeable membrane is defined as follows:

$$Q_w = (\Delta P - \pi \Delta) K_w * s/d$$

where

$Q_w$  is the rate of water flow through the membrane

$\Delta P$  is the hydraulic pressure differential across the membrane

$\pi \Delta$  is the osmotic pressure differential across the membrane

$K_w$  is the membrane permeability coefficient for water

$S$  is the membrane area

$d$  is the membrane thickness.

## Salt transport

The rate of salt flow through the membrane is defined as:

$$Q_s = (C_m - C_p) * K_s * S/d$$

where:

- Q<sub>s</sub> is the flow rate of salt through the membrane
- K<sub>s</sub> is the membrane permeability coefficient for salt
- C<sub>m</sub> is the salt concentration at the membrane surface
- C<sub>p</sub> is the salt concentration in the permeate
- S is the membrane area
- d is the membrane thickness.

## CONCENTRATION POLARIZATION

The value of the concentration polarization factor of 1.2 corresponds to 18 percent permeate recovery for a 40 inch-long membrane element.

As feed water flows and salts are rejected by the membranes, a boundary layer is formed near the membrane surface, in which the salt concentration there exceeds the salt concentration in the bulk solution. This increased salt concentration is called concentration polarization. This effect of concentration polarization is to reduce the actual product water flow rate and salt rejection versus theoretical estimates. The effects of concentration polarization are as follows:

- greater osmotic pressure at the membrane surface than in the bulk feed solution ( $\Delta P - \pi\Delta$ )
- reduced water flow across the membrane (Q<sub>w</sub>)
- increased salt flow across the membrane (Q<sub>s</sub>)
- increased probability of exceeding solubility of sparingly soluble salts at the membrane surface, and the distinct possibility of precipitation causing membrane scaling.

The Concentration Polarization Factor (CPF) can be defined as a ratio of salt concentration at the membrane surface (C<sub>s</sub>) to bulk concentration (C<sub>b</sub>):

$$CPF = C_s/C_b$$

An increase in permeate flux will increase the delivery rate of ions to the membrane surface and increase C<sub>s</sub>. An increase of feed flow increases turbulence and reduces the thickness of the high concentration layer near the membrane surface. Therefore, the CPF is directly proportional to permeate flow (Q<sub>p</sub>), and inversely proportional to average feed flow (Q<sub>f</sub>):

$$CPF = k_p * \exp(Q_p/Q_f)$$

where k<sub>p</sub> is proportionality constant depending on system geometry.

Using the arithmetic average of feed and concentrate flow as average feed flow, the CPF can be expressed as a function of the permeate recovery rate a of membrane element (R<sub>i</sub>):

$$CPF = k_p * \exp(2R_i/(2-R_i))$$

## Saving energy using a pressure exchanger (PX) in the RO System

In the desalination system, the concentrate is released under high pressure to win back the energy from the concentrate flow. The concentrate flow from the membranes is directed through the pressure exchanger, where it directly transfers energy to part of the incoming feed water with maximum affectivity. The features and advantages of the pressure exchanger include that it reduces the HP pump size by approximately 60 percent, has a high efficiency energy transfer up to 94 percent, and drives energy consumption under 2 to 3 kwh/M3.

### PX main principle

In the conventional system, all feed has to go through the high pressure pump, a process with an efficiency of less than 90 percent. Applying PX Technology to salt water reverse osmosis has achieved a high reduction in power consumption where reject brine passes through the PX unit and its pressure is transferred to the incoming sea water. This sea water then passes through a small booster pump to join the sea water from the high pressure pump, as demonstrated in Figure 9 below.

Figure 9: Implementation of pressure exchanger in RO systems

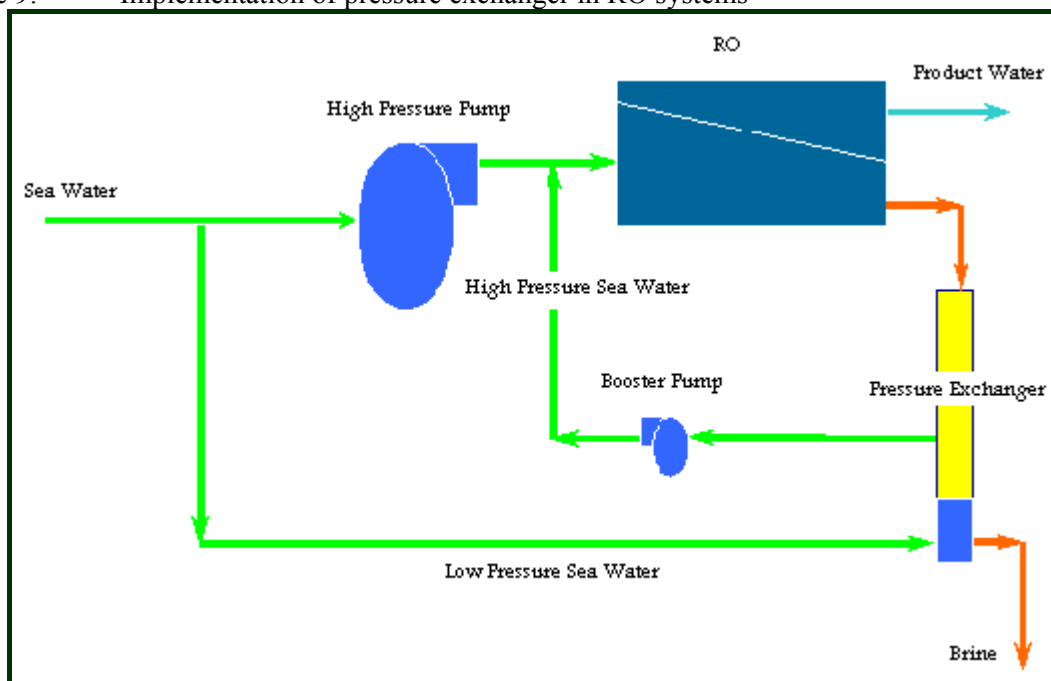

## REVERSE OSMOSIS PRODUCT WATER COST CALCULATIONS

The most critical parameters in cost evaluation are the fixed charges and the energy cost for the production of desalinated water. Other factors that may have lower effect on the unit product cost include the cost of chemicals and labour.

The following method of calculation may be used to calculate the cost of water desalinated by reverse osmosis technology. The calculations proceed as follows:



Calculate the amortization factor  
 $a = i(1+i)^n / ((1+i)^n - 1)$

Calculate the annual fixed charges  
 $A1 = (a) (DC)$

Calculate the annual electric power cost  
 $A2 = (c) (w) (f) (m) (365)$

Calculate the annual chemical cost  
 $A3 = (k) (f) (m) (365)$

Calculate the annual membrane replacement cost  
 $A4 = 10\% \text{ of membrane purchase cost}$

Calculate total annual labor cost  
 $A5 = (l) (f) (m)$

Calculate total annual cost  
 $At = A1 + A2 + A3 + A4 + A5$

Calculate unit product cost (m<sup>3</sup>)  
 $As = At / ((f) (m) (365))$

Calculate unit product cost (m<sup>3</sup>/d)  
 $As = At / ((f) (m) (365))$

## **FOULING AND SCALING OF THE REVERSE OSMOSIS SYSTEM**

Fouling and scaling are the major operational problems that affect the overall performance of a reverse osmosis plant, such as by increasing the maintenance costs and reducing membrane life. When designing a plant, in order to minimize these operational problems, a detailed study should be undertaken on feed water quality and the required pre-treatment system. Consideration should also be given to the earlier-mentioned performance parameters.

### **Scaling**

Scaling is concerned with the seclusion of suspended inorganic partials, including the following:

- calcium carbonate
- calcium sulfate
- silica complexes
- barium sulfate
- strontium sulfate
- calcium fluoride

It should be stressed that the formed scale is made of several compounds. This is because the first compound being precipitated would provide nucleation sites for other compounds.

## Fouling

Fouling is concerned with the seclusion of organic, colloids and suspended particles. Bacteria and other microorganisms that decompose these particles will create substrates. As a consequence they will grow and develop further. Fouling affects reverse osmosis performance by gradual deterioration of the system's performance. This includes a period of rapid decline followed by an asymptotic limit. Performance is affected by a decrease in the permeate flux, increase in pressure drop and decrease in salt rejection.

The bio-fouling potential depends on feed water conditions, system design, and operating conditions. Feed water temperature is a very important parameter, as in the Gulf and equatorial regions, the seawater temperature during the long summer period remains close to 30 °C. Such conditions are highly favorable for bacterial growth and biofilm formation and the effects of these trends are examined in the case study below.

## CASE STUDY AT SUR DESALINATION PLANT-OMAN

This case study examines seawater reverse osmosis membranes (B-10 of Dupont) at Sur, Oman. The Sur reverse osmosis desalination plant (two separate trains) was commissioned in 1993 and has a production capacity of 1,000,000 GPD of drinking water.

Raw water from the beach well is collected in a buffer tank. From there it passes through DMF, 5 um CFs and then to the membranes. The membranes are Dupont HFF-B10 models. All the saline water lines are made of TRP. The pipes outside the reverse osmosis hall are epoxy painted to avoid light diffusion. Those inside are not painted. There is no continuous chlorination, but the low pressure part up to the redox point (SMB addition point after the cartridge filter) is chlorinated every week. The whole system is kept anaerobic during normal operation. Once a month, membranes as well as the high pressure system are given shock SMB sterilization by 100 ppm SMB. The SMB is injected at the suction of HP pump.

The plant operation was good and the differential pressure has been almost steady at 1.5 bar. By the end of September, a gradual increase in the differential pressure of both streams was registered (see Figure 10 below). It has to be noted that:

- there was no increase in the feed pressure
- there was no decrease in the product flow
- feed water composition was unchanged
- SDI was normal
- there was no increase in the salt passage.

Figure 10: Increase in differential pressure-Sur RO plant – Sep to Apr following year

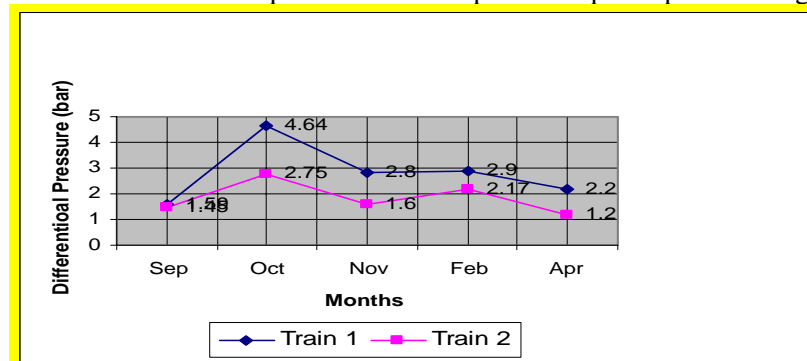

## **Probable reasons and conclusions for differential pressure**

The primary potential causal factor was that of biofouling of the membranes. However, if the increased pressure was due to biofouling, the rise would have peaked within four days, but the rise was very slow. The cartridge filters were clean. There was no reduction in the product flow and no increase in the reverse osmosis inlet pressure. The average rise in differential pressure of reverse osmosis Train 1 was different from that of reverse osmosis Train 2. In short, biofouling has to be ruled out.

Though doubtful, colloidal fouling has to be considered as well. Here also the SDI was normal (less than 0.3). The cartridge filter was found to be clean. There was no decrease in product flow. The rise in differential pressure was not similar for both trains. So colloidal fouling also has to be ruled out.

The cartridges were changed but the rise in differential pressure continued, and the feed header was opened for inspection. In the inner surface of the FRP pipes, more than a thin layer of puffy deposit was found and easily removed with a plastic brush. The growth was found only on a particular stretch of the unpainted FRP pipe.

It was concluded that the growth was most likely some kind of botanical growth. The color was brownish with light green tinges, thus it was most probably some kind of algae, such as brown algae. This algae theory appears to explain all that was observed. Initially, the algae might have entered from the raw water source and now also may be entering the pipe. The algae started growing where the conditions were optimum, thus assuming three primary conditions were found: food, light and an absence of anti-fungal agents.

The particular length of pipe where the growth was found features all three required conditions for algae growth. That area where algae growth was not found meant that one of the required conditions was not satisfied. The static mixture area was painted. That stretch near the suction of HP pump was SMB shock treated every month. However, the particular part of the pipe where the growth was found was not undergoing chlorination or SMB shock treatment and there was diffused light entering and food all along it.

The SS feed lines to the membranes were opened for inspection and there was no algae growth. Further, it was assumed that the SS high pressure lines or membranes would not have any kind of growth since both were undergoing SMB shock treatment and there was no light available. In short, it was those detached algae particles that were accumulating on the membranes' web and causing the differential pressure increase.

It is to be noted that all FRP pipelines outside the reverse osmosis hall were painted during construction of the Sur reverse osmosis desalination plant. This painting was carried out to avoid diffusion of sunlight to the FRP line and to eliminate the algae growth. Inside the reverse osmosis hall, the FRP lines are not painted, there is no possibility of sunlight entering the covered area, and in any case it is not intense enough to aid algae growth.

In this case it was proven that even the very smallest amount of diffused sunlight in the reverse osmosis hall is enough for the growth of algae. Due to the very low light intensity, the growth is also much slower and takes a long time to affect the reverse osmosis membranes' performance.

After the inspection, the pipes were physically cleaned and sterilized with chlorine and the plant was re-opened. Immediately afterwards, the differential pressure rapidly increased to a certain level and stayed there. It was assumed that the rise was due to the sudden influx of particles from the cleaning procedure. The streams were shut down and given a high flow flushing. This reduced the differential pressure to a good extent because the high flow flushing forced out some of the entrapped bigger algae particles in the membranes and decreased the differential pressure. In short, it could be said that even

the diffused light available in the reverse osmosis hall is enough to aid the growth of algae in the FRP feed lines.

## **CONCLUSION**

In response to the high increase in water demand in Oman, desalination was deemed the best solution to help meet drinking water needs and to highlight water issues. The reverse osmosis membrane process could be considered an effective means of producing fresh water, however, experiences in the Sur desalination plant in Oman emphasize that utilizing this technology either for brackish or sea water sources must be handled with intensive care and knowledge.

To design a reverse osmosis plant, all possible information should be collected on many important aspects of its operation, such as: geology, hydrology, climate, water chemistry, membranes, chemicals treatments, as well as previous local experiences in similar projects located nearby. Consideration of this information will provide valuable assistance to optimizing treatment processes. The selection of a membrane on the basis of its production flow-rate, without considering such parameters, will likewise greatly affect the performance and lifetime of the reverse osmosis membrane.

## **REFERENCES**

El-Dessouky-H.T, Ettouney-H.M., *Fundamentals of Salt Water, Desalination*, Elsevier 2002, ISDN0-444-50810-4-2002.

ERI Manual, PX Technology

Hydranautics, Hydranautics RO system design software, version 6.4, 1998.

Lnnotech Water Treatment Desalination Installation System Design 1998 – 2004.

*Filmtech Membranes*, Technical Manual, 2002.

*Technical Management of RO System*, S.El-Manharawy, A.Hafez, 329-344.

# QUALITY ASPECTS OF RECLAIMED DOMESTIC WASTEWATER IN JORDAN

Uleimat, Ahmed Ali; Head, Environmental Monitoring and Assessment Division, Water Authority Of Jordan (WAJ); Email: ulimat\_jor@yahoo.com

## ABSTRACT

In this paper, a summary of Jordan's experience as a developing country managing the quality of reclaimed wastewater is presented and linked to water related issues.

Jordan is an arid to semi-arid country: more than 90 percent of Jordan receives less than 200 mm of rainfall per year and approximately 85 percent of the total average rainfall in Jordan is lost to evaporation. The remaining rainfall recharges ground water and contributes to rivers, *wadi* flows, and reservoirs.

In many Jordanian cities, residents receive water only sporadically, and domestic water consumption is among the lowest in the world, at a rate of less than 100 litres per capita per day. With the advent of industrialization and increasing populations, the range of requirements for water has increased together with greater demands for higher quantity and quality of water. The most feasible options for reducing the gap between water demand and supply include: improved management of existing water resources, treating wastewater for reuse, and the rehabilitation of existing water sources.

At the national level, the Ministry of Water and Irrigation is responsible for administering water policy, pollution control and managing water resources. This paper examines different aspects of reclaimed domestic wastewater in Jordan and shows how this important resource has been considered by Jordan government, through treatment plants, integrated resources and information and management systems.

Specifically, the following topics are addressed: definitions of wastewater; government policy - *Reclaimed wastewater standard no.893/2002*: the means and ways to protect water resources from the effect of wastewater quality deterioration; physical, chemical and biological properties of wastewater; monitoring activities, treatment plants efficiencies and costs of treatment. The paper ends with conclusions and recommendations.

## INTRODUCTION

The Directorate of Laboratories and Quality, through the Division of Environmental Monitoring and Assessment of the Government of Jordan, monitors wastewater all over the country. Reclaimed wastewater discharged from domestic wastewater treatment plants is an important component of Jordan's water budget. In the year 2003, about 94.0 MCM of wastewater was treated and discharged into various water courses, or used directly for irrigation and other specific purposes.

Effective protection of the environment requires accurate and detailed knowledge of existing environmental conditions and the ability to detect and measure water quality trends. The monitoring of reclaimed wastewater quality involves many distinct activities to give reliable and usable data.

A monitoring program for domestic wastewater is designed according to the Reclaimed Domestic Wastewater standard (JS 893/ 2002) issued by the Jordanian Institute of Standards and Metrology (JISM). This Jordanian standard is purposely set to specify the conditions that the reclaimed domestic wastewater discharged from wastewater treatment plants should meet, in order to be discharged or used in the various fields mentioned in this standard.

It is the intent of these regulations to encourage and facilitate the productive and safe reuse of treated wastewater as a viable option in the management of Jordan's scarce water resources. The use of treated wastewater for non-potable purposes, through source substitution or replacing potable water used for non-potable purposes, is encouraged.

Minimum standards for the reuse of treated wastewater are defined in these regulations. They address the primary health concerns associated with the reuse of treated wastewater. The regulations also establish criteria to address the risk of pathogen exposure and infectious disease risks associated with various specified uses of treated wastewater. Other standards define the extent of wastewater treatment required, treatment reliability requirements, upper limits for water quality parameters, site access restrictions and management practices.

In addition, the standards are to address the parameters to be monitored, frequency of monitoring, record keeping and reporting requirements when treated wastewater is reused. These regulations establish the degree of control required for wastewater reuse through site access limitations, management practices and crop restrictions that will be commensurate with the level of treatment provided, reliability of the treatment process, quality of the wastewater and the intended use. As the quality of the wastewater and the reliability of the treatment process increases, the regulatory controls are reduced to a level consistent with protecting public health and the environment. Pathogen reduction and public health impacts related to infectious disease agents are the major concerns associated with the reuse of treated wastewater. Reclaimed water is sampled according to the frequency that standard and representative samples are taken, at a point before reclaimed water leaves the premises of the treatment plant. It is then analyzed through quality assessment and laboratories' accreditation processes. In fact, sewage treatment is a multi-stage process used to renovate wastewater before it re-enters a body of water or is reused. The goal is to reduce or remove organic matter, solids, nutrients, disease-causing organisms and other pollutants from wastewater. Treatment plants should reduce pollutants in wastewater to a level nature can handle.

### **What is wastewater and why treat it?**

Wastewater is not just sewage. All water used domestically that enters drains or the sewage collection systems is wastewater, including water from baths, showers, sinks, dishwashers, washing machines, and toilets. In combined municipal sewage systems, water from storm drains is also added to the municipal wastewater sewer system.

The average Jordanian contributes less than 100 litres of wastewater each day. Wastewater is about 99.85 percent water by weight and is generally referred to as influent when it enters the treatment plant. Domestic wastewater primarily comes from individuals, and doesn't generally include industrial wastewater. Moreover, domestic wastewater in Jordan may include industrial wastewater from industries connected to the public sewer system.

### **Wastewater treatment**

There are 20 existing public-sector wastewater treatment plants in Jordan, each using a different type of treatment system. The treatment systems comprise trickling filters, activated sludge and waste stabilization ponds as shown in Table 1 (below).

Table 1: Wastewater Treatment Plants in Jordan

Treatment System	Treatment Plants
Activated Sludge	Irbid, W.Arab, Wadihasan, Salt, Madaba, Abo Nusier, Tel Mantah, Fuhais, Wadi Musa, Ramtha,
Trickling Filter	Kufranja, Tafilah, Baqah, Karak
Stabilization Ponds	Samra, Maan, Mafraq, Aqaba, Wadi esseir

A common set of processes that might be found at a municipal treatment plant includes preliminary, secondary and sometimes tertiary treatment. Preliminary treatment is undertaken to remove large or hard solids that might clog or damage other equipment. It includes use of primary settling basins, rectangular or circular in shape, where the water flows for up to a few hours, to allow organic suspended matter to settle or float to the surface.

Secondary treatment, a type of wastewater treatment used to convert dissolved and suspended pollutants into a form that can be removed, produces a relatively highly treated effluent. It utilizes biological treatment processes followed by settling tanks that remove approximately 85 percent of the Biochemical Oxygen Demand ( BOD) and Total Suspended Solids (TSS) in the treated wastewater. Secondary treatment for municipal wastewater is the minimum level of treatment required in Jordan for reclaimed water.

Tertiary treatment is therefore any level of treatment beyond secondary treatment, which could include filtration, nutrient removal (removal of nitrogen and phosphorus) and removal of toxic chemicals or metals. This last type and level of treatment will be used in the new Aqaba treatment plant.

### **Jordanian wastewater quality standards**

The Water Authority of Jordan (WAJ) follows national legislation that has been issued by the Jordanian Institute of Standards and Metrology (JISM) and regulations issued by the Minister of Water and Irrigation. The most important legislated standards governing wastewater management can be summarized as follows:

JS 893/2002: this national standard addresses the properties, quality control and other requirements for reclaimed water, specifically those that domestic wastewater must meet before being discharged to any receiving body or reused for agriculture or other intended uses.

JS 202/2004: this standard deals with industrial wastewater that is produced after being used for industrial purposes. The aim of implementing an industrial wastewater monitoring program is to protect the environment and water resources and to safeguard health and human safety.

Regulations issued by the Ministry of Water and Irrigation in 1998 according to WAJ Law number 18/1988. These regulations deal with industries to be connected to public sewer systems in order to control releases of wastewater to sewer pipelines and treatment systems. Each industrial establishment should obtain permission to connect its effluent to sewer system.

### **MONITORING ACTIVITIES**

The wastewater monitoring programs which are implemented at laboratories and by the Quality Control Department are summarized in the following sections.

### ***Domestic wastewater quality monitoring program***

The first part of the program focuses on monitoring the effluents and influents of public treatment plants that are operated by Water Authority of Jordan. These plants comprise mainstream technologies that are commonly used throughout the world and are classified as per the three types listed in Table 1 above.

The second part focuses on monitoring the effluents of 20 treatment plants that are operated by the private sector, such as Mut'a Treatment Plant, Ma'een Treatment Plant and others. The basic objective of this program is to control the pollution loads and minimize their effects on ground and surface water. This objective can be achieved by having a well-designed operational system, such that its effluent complies with national standards and the reclaimed water can be used in different ways.

### ***Streams, wadis, dams and reservoirs monitoring program***

This program is designed to monitor a total of 60 selected sites such as King Talal Dam, Wadi Kfrein Dam, and others, which receive direct flow from domestic wastewater treatment plants, in order to measure the pollution loads and effects on water resources and the environment. The generated water quality data will be evaluated and its suitability for irrigation depends on a variety of factors such as total dissolved solids, concentration of ions, pathogens and others.

### ***Industrial wastewater monitoring program***

This program focuses on monitoring the effluents from more than 175 industrial establishments. These factories are classified as follows:

- Industries connected to the sewer system: the evaluation of the water quality is based on WAJ regulations issued in 1998 in order to protect the sewer pipelines and the treatment plant system.
- Industries not connected to the sewer system: the evaluation is based on the Industrial Wastewater Standard 202\2004 which is specified for factories dumping their waste to the environment.

The overall value of implementing this monitoring program is to protect the water resources from the toxic materials and pollution loads resulting from the industrial emissions.

### ***New approaches to water monitoring***

The role of government in monitoring water resource management is being reevaluated in Jordan. The high public sector involvement characteristic of the old model - whereby the government is fully responsible for water resource management in financial and organizational terms - is being replaced by increased private sector participation. This new approach, of involving the private sector, is outlined in the law *JS 202\2004*. Specifically, the private sector is implementing its own monitoring programs, taking into consideration the type and the flow for each factory. This type of approach is already practiced in the USA, Canada and European countries.

### ***Wastewater analysis***

Various types of pollutants are present in domestic wastewater and can be measured by many different parameters such as *Escherichia coli* (E.coli), Helminthes eggs, physical parameters, chemical parameters and heavy metals. The most important class of wastewater contaminants are compounds that react with oxygen which are characterized by Chemical Oxygen Demand (COD) and Bio-



chemical Oxygen Demand ( BOD) and the second class is suspended solids that determine the quality of reclaimed water and its uses to achieve sustainability in environmental issues and public health.

### Wastewater evaluation

The quality of irrigation water is of particular importance in arid zones where extremes of temperature and low relative humidity result in high rates of evaporation, with consequent deposition of salt which tends to accumulate in the soil profile. The physical and mechanical properties of the soil, such as dispersion of particles, stability of aggregates, soil structure and permeability, are very sensitive to the type of exchangeable ions present in irrigation water. Thus, when effluent use is being planned, several factors related to soil properties must be taken into consideration. Another aspect of this which has implications for agriculture is the effect of dissolved solids (TDS) in the irrigation water on the growth of plants. Many of the ions which are harmless or even beneficial at relatively low concentrations may become toxic to plants at high concentration, either through direct interference with metabolic processes or through indirect effects on other nutrients, which might be rendered inaccessible. Important agricultural water quality parameters include a number of specific properties of water that are relevant in relation to the yield and quality of crops, maintenance of soil productivity and protection of the environment. These parameters mainly consist of certain physical and chemical characteristics of the water. Tables 2 and 3 (below) present a list of some of the important pathogenic, physical and chemical characteristics that are used in the evaluation of reclaimed water quality.

The water quality data generated as shown in Tables 2 and 3 below are evaluated according to the *Reclaimed Domestic Wastewater standards* (JS 893/ 2002, standard no. 893/2002). After the evaluation process, the directorate issues monthly, quarterly, biannual and annual reports that show treatment plants which violate the standard. The objective of issuing these reports is to address the problems and seek correction to protect against and minimize their effects on resources and the environment. Moreover, the raw water quality differs from one type of treatment to another, depending on the operation conditions and the treatment system. For example, the BOD5 that measures the amount of oxygen micro organisms require to break down sewage in five days. Untreated sewage has a BOD5 ranging from 475mg/L at the plant WadiArab T.P to 1137 mg/L at the plant Madaba T.P. This means that it is a strong concentration when comparing it with raw sewage in the USA, which ranges from 100-300 mg/L. Table 4 shows the differences between levels of untreated wastewater concentration from one governorate to another.

Table 2: Reclaimed Wastewater in Jordan

WWTPs	NH4	BODf	(BOD)	(COD)	E. coli	Nitrate	FOG
Average	mg/l as N	mg/L	mg/L	mg/L	MPN/100 mL	mg/L	mg/L
Abu Nusseir	1.17		10.57	50.22	114.13	5.66	20.50
Alkherbah							
Alsamra	78.20	36.29	88.55	309.50	13167.23	0.24	34.67
Aqaba	33.13	63.00	123.80	473.50	4714.72	0.97	20.75
Baqaa	24.10		24.11	109.80	130834.3	3.43	20.00
Fuheis	45.95		11.90	84.13	6	1.26	13.33
Irbid	58.10		22.33	124.70	8.99	1.87	33.50
Jarash	96.88		54.50	274.33	20.29	0.47	19.17
Karak	45.18		33.90	171.75	17571.02	0.42	
					2867874.		
					63		

WWTPs Average	NH4	BODf	(BOD)	(COD)	E. coli	Nitrate	FOG
	mg/l as N	mg/L	mg/L	mg/L	MPN/100 mL	mg/L	mg/L
Kufranjah	62.02		35.80	137.60	25859.01	4.83	14.25
Maan	55.97	41.60	110.80	240.50	1555209.74	0.43	9.33
Madaba	2.36		21.73	284.67	13128.96	2.78	23.75
Mafrq	101.58	75.17	190.83	430.33	2690224.22	0.30	18.75
Ramtha	1.20	102.00	39.43	276.29	220.95	6.43	19.83
Salt	17.29	7.00	19.67	66.90	1483.46	0.65	24.50
Tafilah	35.20		24.33	108.56	645421.76	12.77	8.25
Tal Mantah	49.15		184.25	1146.50	68.20	88.07	20.63
Wadi Arab	0.50		8.29	56.40	489.75	46.57	32.83
Wadi Aseir	38.40	9.50	16.17	91.75	4876.03	12.06	19.25
Wadi Hassan	0.85		9.13	56.83	87.17	28.90	26.75
Wadi Mousa	0.50		7.25	50.00	8.82	14.77	9.27

Table 3: Reclaimed Wastewater in Jordan

WWTPs Average	Phosphate	Sulfate	TDS	TN	TSS	Turb.	pH
	mg/l as P	mg/L	mg/L	mg/L	mg/L	NTU	unit
Abu Nusseir	14.83		1031.75	8.49	82.00		7.58
Alkherbah							
Alsamra	11.28	66.70	1176.00	106.59	141.67	78.20	7.79
Aqaba	1.83		1952.00	61.84	362.75	121.67	7.73
Baqaa	21.61		1415.60	41.52	91.09	125.00	7.78
Fuheis	19.29		900.86	56.63	59.90	9.72	7.89
Irbid		140.00		71.93	59.33	22.53	7.62
Jarash	28.90	60.85	1281.00	131.57	202.00	163.40	7.22
Karak	14.82	80.00	943.80	56.25	115.55		7.91
Kufranjah		70.70	1000.00	82.95	68.50	30.78	7.88
Maan	10.20	76.00	927.75	77.29	197.60	56.80	7.93
Madaba	1.62		1301.56	7.46	294.33	83.92	7.90
Mafrq		62.40	1087.40	131.04	233.67		7.93
Ramtha		78.45	1186.40	25.86	159.00	6.59	8.08
Salt	20.61		792.22	22.23	83.82	7.99	7.82
Tafilah	12.00		1010.89	57.69	84.73	8.07	7.78
Tal Mantah		175.65	2054.43	112.78	685.71	5.03	6.88
Wadi		87.00	1096.80	52.72	54.17	15.86	7.65

WWTPs Average	Phosphate mg/l as P	Sulfate mg/L	TDS mg/L	TN mg/L	TSS mg/L	Turb. NTU	pH unit
Arab							
Wadi Aseir	7.49		939.50	59.27	55.00	15.15	7.92
Wadi Hassan		55.90	1276.57	32.95	42.63	67.46	8.02
Wadi Mousa	5.84		1033.43	16.60	161.57	6.15	8.09

Table 4: Raw Wastewater in Jordan

T.P	BOD(mg/l)	T.P	BOD(mg/l)
Madaba	1137	As-samra	693
Jerash	1114	Tafila	691
Kufranja	1076	Karak	654
Irbid	1066	Maan	607
Baqaa	986	Fuhis	604
Salt	848	Wadi Alseer	538
Wadi Hassan	802	Wadi Mousa	527
Mafrag	728	Abu-Nusir	525
Wadi Arab	709	Aqaba	475
Ramtha	696	As-samra	693

### Treatment plants' efficiency

The efficiency of 20 treatment plants, as shown in Table 5 (below) and measured by BOD5 as an indicator of removing dissolved organic matter from treated sewage, range from 71 percent (as for the Maan treatment plant) to 99 percent (as for the Wadi Arab treatment plant). The efficiency of the wastewater treatment plants and the operation systems used in Jordan for the year 2003 is shown in Figures 1 and 2 (below). The figures clarify that the activated sludge is very effective in removing dissolved organic matter and WAJ can rely on it as a first choice for wastewater treatment and after that the trickling filter. The historical data show that the wastewater stabilization ponds have a low efficiency in removing dissolved organic matter, which is clear from Figure 1, evaluated according to the Reclaimed Domestic Wastewater Standard JS 893/2002.

Table 5: Treatment Plant Efficiency-

T.P	Efficiency	T.P	Efficiency
Madaba	96.1	As-samra	83.2
Jerash	95.4	Tafila	92.6
Kufranja	93.8	Karak	93.3
Irbid	94.8	Maan	71.3
Baqaa	94.7	Fuhis	95.1
Salt	96.4	Wadi Alseer	89.6
Wadi Hassan	96.5	Wadi Mousa	97.3
Mafrag	76.4	Abu-Nusir	97.5
Wadi Arab	96.1	Aqaba	70.4
Ramtha	72	As-samra	83.2

Figure 1: Treatment System Efficiency

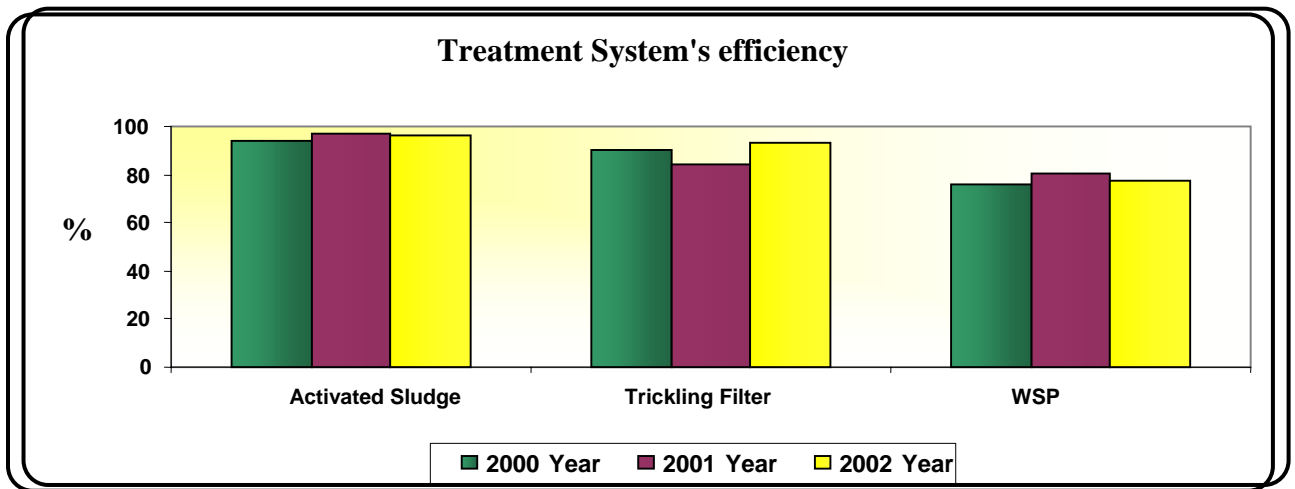

Figures 2(a) and 2(b): Domestic Wastewater Treatment Plant Efficiencies 2003, 2002

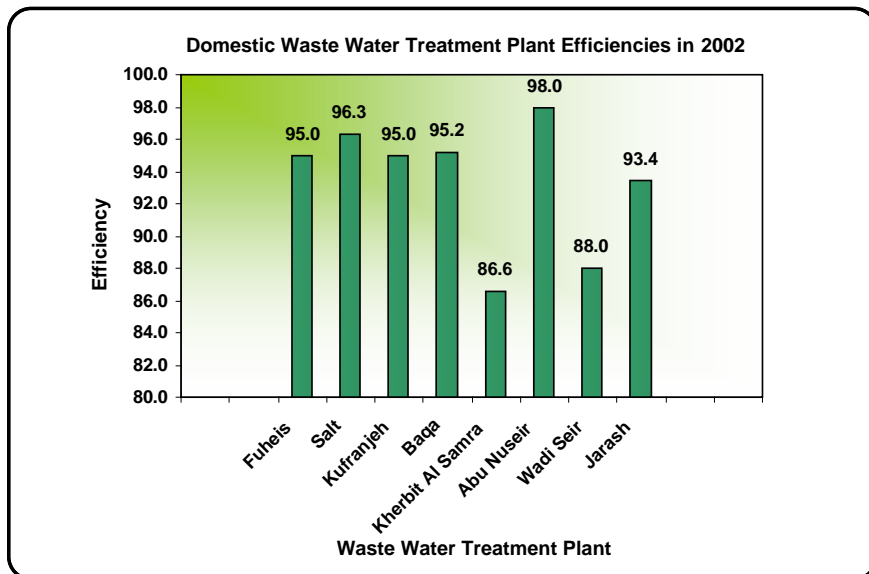
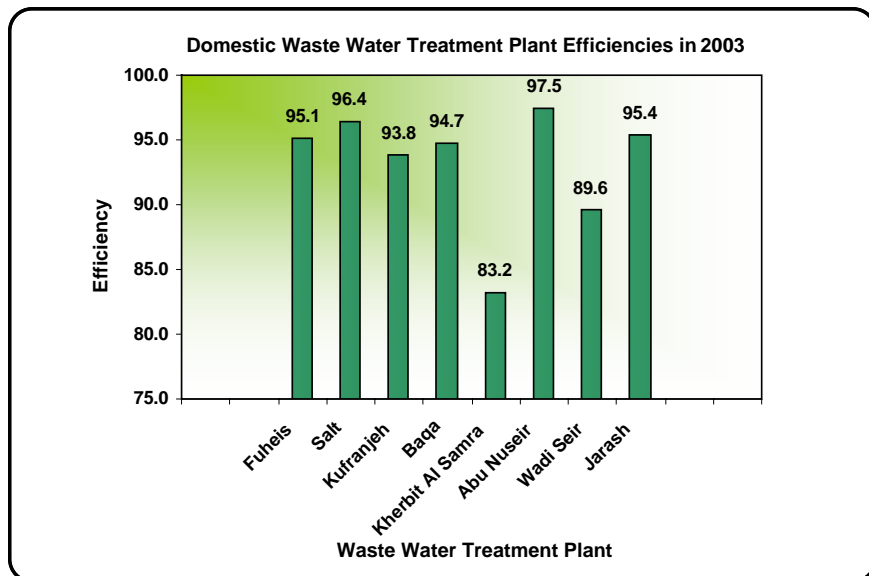

## Evaluating progress

Wastewater treatment plants operate at a critical point of the water cycle, helping nature defend water from excessive pollution. The Water Authority of Jordan has so far provided sewer and treatment system services. Currently, there are 20 treatment plants in Jordan each working 24 hours a day. The number of connections realized by the end of the year 2003 is 172,133 and 67 percent of these connections flow to the Samra treatment plant.

### Treated wastewater quantity

In 2003, the quantity of wastewater that flows to treatment plants was about 94.1 MCM as shown in Table 6, representing a 6.27 percent increase from 88.6 MCM in 2002. Moreover, 72.5 percent of wastewater was treated at the Samra treatment plant. The quantity of reclaimed water was about 74 MCM used in different aspects in the year 2003. In fact, the Jordanian Water Authority seeks to attain total water reuse by having highly treated effluent used as specified in the national policy document issued in 1997: the Jordan Water Strategy.

Table 6: Treated water quantities, Source: Wastewater Department

Year	1994 M3\day	1996 M3\day	1998 M3\day	2000 M3\day	2001 M3\day	2002 M3\day	2003 M3\day
Samra	129177	148795	168857	170752	186081	178902	1868
Aqaba	5488	6666	8219	8804	9310	9329	1033
Irbid	7238	8149	8474	4610	5081	7121	8103
Salt	3761	4053	3825	3403	3598	3898	4248
Jerash	1354	1524	1804	2072	2743	2913	4359
Mafrq	1317	2379	2297	1847	1889	1805	2189
Baqa	5214	6891	8783	11185	11516	11768	1205
Karak	1071	1266	1122	1231	1275	1508	1574
Abo-nussair	1532	1463	1499	1617	1800	1977	2215
Tafila	936	966	862	707	736	740	844
Ramtha	1247	1414	1617	2340	1889	2300	3071
Maan	1350	1672	1923	1892	1556	2155	2119
Madaba	2077	2693	3219	4266	4611	4178	4422
Kufranja	690	1517	2240	1889	1864	2223	2787
Wadi esair	-----	-----	819	1113	1402	1917	2445
Fuhais	-----	-----	847	1218	1217	1532	1944
WadiArab	-----	-----	----	5985	5735	7063	6667
WadiMou sa	-----	-----	-----	-----	532	866	900
WadiHass an	-----	-----	-----	-----	280	423	725
TotalM3\day	162452	189448	216407	224931	243115	242609.9	2578
Total (MCM)\Year	59.3	69.3	79.0	82.3	88.7	88.6	94.1

## Cost of treatment

Treatment costs differ from one treatment plant to another. The minimum cost was 16.2 *fi*ls per meter cubed at the Aqaba treatment plant in Jordan local currency and the maximum cost was 798.4 *fi*ls per cubic meter at the Wadi Musa treatment plant. Table 7 shows the cost of treatment for 19 treatment plants for the year 2003.

Table 7: Cost of Treatment, Source: Wastewater Department

WWTP Name	Cost Fils/m <sup>3</sup>	WWTP Name	Cost Fils/m <sup>3</sup>
Aqaba	16.2	Salt	107.0
As-samra wsp	18.6	Abu-nuseir	119.6
wadiessir	39.6	Karak	142.0
Ramtha	46.7	Madaba wsp	142.7
Mafraq	57.5	Wadi Arab	145.4
Baqaa	65.3	Fuheis	164.5
Jerash	69.3	Tafila	232.7
Maan	69.5	Wadi hassan	484.1
Irbid	75.4	Wadi mousa	798.4
Kufranja	100.0	Tel.Mantah	-

## CONCLUSIONS

Water reclamation and reuse have rapidly increased in recent years, clearly indicating the recognition and commitment at the highest level of government in Jordan as to the full value of reclaimed water for the overall water resources of the country.

Current reclaimed wastewater standards regulate water reuse and environmental discharges to ensure optimal performance of the wastewater treatment plants. However, a reclaimed wastewater monitoring program should be implemented according to the Reclaimed Domestic Wastewater Standard JS 893/2002. The Wastewater Treatment Plant owner must ensure that the reclaimed water quality complies to the standards and according to its end use, verifiable by documented laboratory tests recorded in official logbooks, to be presented upon request to governmental monitoring parties.

There is a need to conduct research projects based on actual uses of reclaimed water. Reclaimed water used for irrigation shall be used with controls that protect the health and safety of workers as well as the general public who may be exposed to the water. Planned reuse programs should be created to stop discharging wastewater effluent to streams and catchments areas.

There is also a need for the active and collaborative involvement of other ministries, agencies and public participation in support of the Water Authority of Jordan to make use of reclaimed wastewater. A national public awareness program should be implemented to encourage people to accept the reuse of reclaimed wastewater for irrigation and other purposes.

## REFERENCES

Department of Wastewater Systems, Water Authority Jordan. 2003 *Wastewater Annual Report 2003*.

FAO *Guidelines for Agriculture*, 1991.

Kerri, Kenneth D. 1998. *Operation of Wastewater Treatment Plants*, Vol-1 EPA,

*Jordanian Reclaimed Wastewater Standard 893/2002*, Government of Jordan.

Labs Annual Report. 2002 and 2003.

Mancl, Karen. *Wastewater Treatment Principles*, [www.ohioline.osu.edu](http://www.ohioline.osu.edu).

Stenstorm, Michael. 1998. *Wastewater Treatment*, [www.ioe.ucla.edu/report 98/wastewater](http://www.ioe.ucla.edu/report%2098/wastewater)

USAID, Standards, Regulations and Legislation for Water Reuse in Jordan , ARD-JANUARY 2002

WHO, 1989. *Reuse of Effluents, Methods of Wastewater Treatment and Health Safeguards*

# DATA AND INFORMATION MANAGEMENT FOR CAPACITY BUILDING OF THE WATER RESOURCES SECTOR IN INDONESIA

M. A. Fulazzak, Senior Expert on Water and Wastewater – Directorate General of Water Resources, Indonesian Ministry of Public Works; Email: fulazzaky@yahoo.com

H. Akil, Senior Information and Communication Technology Expert of Capacity Building for Water Resources Project, Indonesian Ministry of Public Works; Email: hilman\_akil@alum.mit.edu

## Abstract

Most provinces in Indonesia will be facing water scarcity problems over the next decades due to increasing water demands resulting from population growth, urbanization and economic and industrial developments. As a consequence, they will also be facing a number of problems with regards water resource management, such as a lack of data and information needed to evaluate the real status of water resources, the unsystematic development of relevant infrastructure and economic instruments, inadequate human resources for the operation and maintenance of water resources, and a lack of interest in improving research and development activities.

One of the key solutions to help solve water resource problems has been to obtain supporting data and information by developing an information system and water resources data center (WRDC). Rapid developments in information and communication technology (ICT) have been used to support data communication and management requests in order to build capacity of the water resources sector, and as a prerequisite for an integrated water resources management program.

This paper examines the application of data and information management for improved water resources management in Indonesia through a “one door data service system” that links the related institutions from different sectors and levels, for both central and regional government agencies.

*Key words: water resources management, data, information*

## INTRODUCTION

The impact of economic development and population growth, forest and land degradation due to legal and illegal logging, and increasing land use for agricultural purposes has negatively impacted available water resources in Indonesia. Over the coming decades the country is facing increasing water scarcity, exacerbated by increased flooding in the rainy season and more droughts in the dry season, as well as high water pollution in major rivers - especially in big cities - if an optimal and comprehensive approach to integrated water resources management is not instigated.

Since 1998, after the downfall of the ‘new order’ era (1965 – 1998), which comprised a period of authoritarianism under former President Suharto, the Republic of Indonesia has been concerned about the need to confront this problem of water management. Pursuant to the reformation era (1998 -2002), a new paradigm of governance was initiated with the issuance of the law 22/1999 on autonomy and decentralization, effectively transferring part of the responsibility for water resource management from the central to local government. At this point, the Government of Indonesia also considered the need to reform the water resources policy by establishing the water resources sector adjustment program (WATSAP) frameworks. A new law 7/2004 on water resources was approved by Parliament, and came into force on March 18<sup>th</sup>, 2004. This important piece of legislation also included reference to the water resources information system, which is described in more detail below.



## **Water resource information system**

This information system aims to produce quality data and information to support the demands of data exchange and water resource management, coordination and integration among various relevant institutions, such as: the Directorate General of Water Resources (DGWR) – Ministry of Settlement and Regional Infrastructures (MSRI), central and regional governments and cross-sector institutions, non-governmental organizations and universities. To achieve this, support from the regional water resource services at the provincial and district levels is required. By using the system to increase planning and development, the DGWR and other related institutions are expected to greatly benefit.

In general, the water resources development program and information system has multiple utilities applications, such as mapping existing basic infrastructure, in order to plan for national infrastructure development. It is also intended to increase the availability, to some degree, of digital data that describes the natural resources and physical condition of existing infrastructures.

The water resources data management and warehouse system comprises a website tool which enables spatial data to be stored and used together with tabular data in a standard database management system, available in response to user needs, so users can instantaneously and interactively generate answers to their queries online.

The information system and application of WRDC was developed by Directorate General of Water Resources, as stipulated in the *Report of Capacity Building Project – Component 7 (2002)*<sup>1</sup> and chosen by gathering ideas through a multi-stage public consultation with users at the ministerial, provincial and district levels. Based on their recommendations, the resulting system was categorized as follows:

- irrigation scheme system;
- water resources potential, such as: river, lake, groundwater and reservoir;
- natural disaster, such as: flood and drought monitoring;
- hydrological data and station networks; and
- other information, such as: products of regulation and policies, institutions.

The WRDC users at the ministerial level working under the DGWR could access the system by using local area network (LAN) connections and other users at the provincial and district levels or elsewhere in the world can use the internet facility for connection and regular browser software for operation.

## **Capacity building for the water resources sector**

Capacity building is needed to support the implementation of an integrated approach to water resources development and management (Barmawi and Amirwandi, 1999). This is further supported by Chapter 18 of Agenda 21 of the UN Framework for Sustainable Development which states that “capacity building is a prerequisite to integrated water resources management”. Agenda 21 has four basic elements pertaining to capacity building - which is deemed to be a long-term continuing process. These elements are:

- the creation of an enabling environment that has an appropriate policy and legal framework;
- institutional strengthening and development, including local participation;
- human resources development, including the strengthening of managerial system and water users interest; and

---

<sup>1</sup> Capacity Building Project Component 7: Project on Improvement in Water Resources Data Management for the Water Resources Sector (under ADB Loan No.1339-INO). The aim of the Project is to support and strengthen activities in the Water Resources Sector by providing a Data Warehouse system of tabular and geographical information for users in government service and others; the information being provided by users of the system in Jakarta and in the Provinces. The Data Warehouse system provide reports from its- holdings of information in geo-relational tables in response to user requests. The system accessible through the Local Area Network (LAN) of the Ministry of Public Works

- awareness building and education at all levels of society.

In relation to these foci, Indonesia has established several institutions for the purpose of implementing water resource policies at national and regional levels, to improve performance of water resources management. Unfortunately, to date they have tended to be inefficient and ineffective, due to a number of factors including a lack of requisite management and monitoring tools needed to ensure the involvement and commitment of the communities and the general public; inadequate funding and human resources; and an under-resourced working environment for the individuals responsible for implementing the water policies.

### **Needs for data management and warehousing**

One potential solution to overcoming the challenges listed above could be based on an extensive assessment of water resources, meaning not only an inventory of the available water resources, but also an assessment of the extent to which a county can satisfy its water requirements, particularly in terms of matching water supply with demand. This would, of course, also include a capacity building component to increase human and social capital.

As a corollary, it was decided that an information system and WRDC be established under the auspices and management of a water resources institution. The DGWR was therefore chosen to deliver to all potential users the following services:

- organize, store and manage all relevant water resource related data
- provide access to the existing data (network, diskettes, reports)
- provide tools for the uses of the data
- retrieval of the tools
- presentation of the tools
- develop standard analytical and spatial tools
- linkage of databases
- provide training and support for the users of the tools
- supply the data's documentation.

The use of an information system and data management, such as data acquisition and processing, can play a critical role in addressing water shortages by determining the best approach to reduce pollution and minimize the gap between water availability (supply) and water use (demand). However, without coordination or adequate dissemination or access to information, the data acquisition and processing undertaken by a single institution remained ineffective: it could not easily be accessed by other researchers and decision-makers, or meet public information demands.

Fortunately, the rapid development of the information and communication technology (ICT) sector and its application to an integrated water resources management program aided the capacity of data communication and management. On the one hand, this fundamental process advocated by Woodward (1997) has entailed improved efficiency and effectiveness of water resource management through the appropriate access to and use of water-related data and information, as well the establishment of a communication system among related institutions. On the other hand, provincial institutions related to water resource management also need to prioritize human resource development through systemic and compulsory education, services, career development and training for enhanced water resources development and management.

### **Importance and benefits of the information system**

The water resource data-warehouse system is embedded in an application that permits spatial data to be stored with tabular data in a standard database management system, such as Microsoft SQL Server. This application system permits a dynamic generation of output coming from the tabular and spatial

data holdings of the system, using core database management (DBM) software like ESRI ArcSDE (where SDE = Spatial Data Engine).

The system also has a comparative advantage in terms of its usability and functionality: the internet-based web-enabled applications and software are more advanced than other conventional systems, such that users can generate responses to their queries online, rather than the simply presenting static maps and tables from the database.

For all of the users from DGWR, access to the system can be gained by using the local area network (LAN) through existing LAN connections. Other users from national, provincial and district level institutions, as well as users elsewhere in the world, can connect to the system via the Internet and using regular browser software. An online messaging system provides client support and a help desk room at the WRDC assists people needing advice on the application of the system. To further support the application of the WRDC and enhance its usability, including the search for contacts, website development has been programmed as a priority activity to be undertaken.

### Architecture of the information system and water resources data center

The DGWR is already undertaking the process of integrating all computing activities. The information system and WRDC provide the physical infrastructure as the hardware system to link the WRDC system to the other information systems as a water resources database network and also services the software system to maintain the sustainability of network connections, as mentioned in the Report of Capacity building Project – Component 1 (1998).

The information system and WRDC consist of a database system whereby all the relevant data is stored on the network server, a shell that combines the spatial and non-spatial data, as well as the application tools to retrieve, present or analyze the data (see Figure 1 below). Besides the hardware and software, protocols and rules as well as request regulations are needed to organize and manage the data flows. Of particular importance is the issue of how to maintain cooperation among all relevant institutions.

Figure 1: Architecture of the information system and WRDC

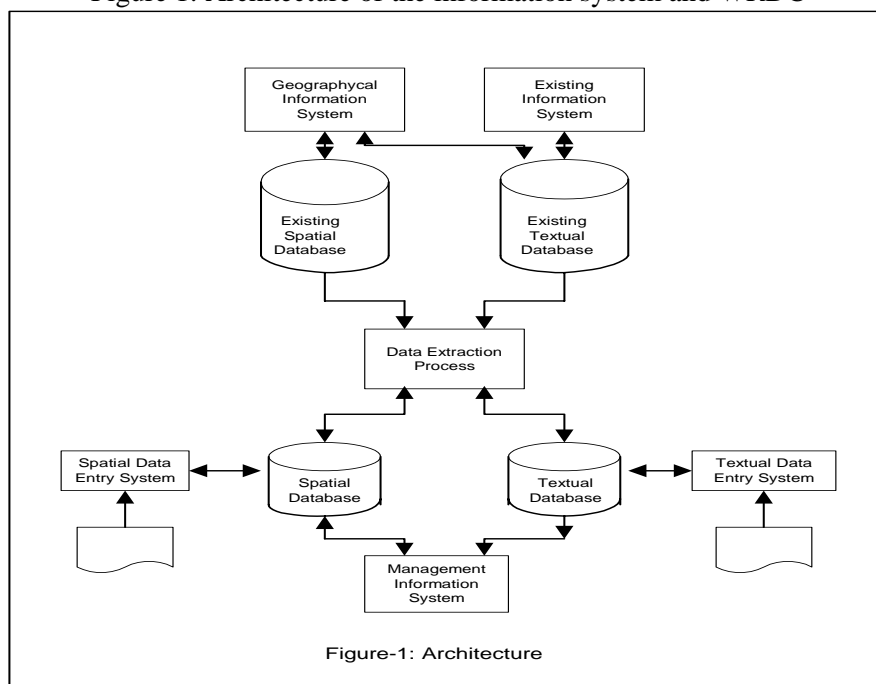

### Data availability

A data warehouse is a data brokerage system. It does not exist to support a single activity or a single project, but rather, it exists to receive and transfer the information to a wide range of users. Presently, it exists to support activities related to water resources and water resources development. A data warehouse is therefore an institutional facility that is quite distinct from the databases developed for individual development projects. The database management system could be provided to users to enable them to optimize their use of the entire resources and services of the data warehouse to organize, store and develop their data into well-developed reports and/or maps, for example. It is anticipated that such reports will be used for meetings as part of on-going, general reporting processes within relevant organizations.

Given that the data warehouse is based on the need for its functionality as well as individually-tailored, interactive and instantaneous outputs like reports and maps, its success is therefore determined by the availability of data and information. In principle, this depends on the type of data requests, user interests and whether users have direct access to the website.

To simplify this situation, six subject areas were selected for the development of web-based applications. They are all important for water resource management and correlate to different types of governance, namely:

- services/administration,
- irrigation scheme systems inventory;
- natural disaster, flood and drought monitoring;
- water resources inventory;
- hydrological infrastructure inventory;
- other information - decrees, regulations and policies and training material; and
- file transfer protocol (FTP) process.

At present, these installed data sets comprise the best available water resource database system in Indonesia. If in some cases the requisite data is not held by the data warehouse system, it is possible to search through a linkage system for databases designed especially for specific users. Currently, users are typically specialists in water resources and are interested in one of the subject areas listed above. However, in future, the number of system applications could rapidly increase and be modified in response to changing user requests. Thus; new functionality will be continuously developed and modified based on such requests, feedback and changes to application requirements from all kinds of users. For example, if a researcher needs the specific river flow data, s/he could be directly linked to another pertinent, specialized Ministry database. Conversely, the researcher could link directly to the data requested using conventional communication methods.

## **APPLICATION OF THE INFORMATION SYSTEM**

In practice, the system will provide standard reports and maps for regular users, ideally using updated data that is supplied by users and entered into the database server by staff working for the information system and WRDC.

The spatial data are stored in the data warehouse along with the tabular data in ArcSDE and the spatial information and GIS capabilities are available via four applications (irrigation scheme systems inventory, natural disaster and flood and drought monitoring, water resources inventory, and hydrological infrastructure inventory). ArcIMS software permits the generation of maps for all four applications. Several GIS tools are available online for each application, with functionalities such as: zoom, attribute or spatial query, buffer and overlay. The following sub-sections present the description of applications constructed under the project.

## **Irrigation scheme systems inventory**

The irrigation scheme systems inventory (ISSI) application was designed and developed as a web-based and stand-alone PC-based application. The ISSI PC-based application is developed in three versions (i.e. national, provincial and district versions) as reported in the Java Irrigation Improvement and Water Resources Management Project (1996). The web-based and PC-based applications are in principal similar. The data input and update are the main reasons why ISSI is differentiated, as it is costly to update directly online via the website.

At a local level, the districts and provinces can use the PC-based application to enter and sort the data on their own computers, and send the updated data files to the WRDC at the national level via the Internet or by mail. The tabular and spatial data are fully integrated in the website version of this application. The application overview is as follows:

Purpose of application: to maintain the data and to present and deliver information on the irrigation scheme systems in a particular area to users in the ministry and on the web.

Data Sources: the data for the ISSI application was drawn from DGWR – Ministry of PW (1994 data) and covers the entire country of Indonesia. Data for 1999 was also collected from the provincial water resources service (Dinas) of the North Sumatra Province.

Output Available: the PC-based users can generate a report for one specific irrigation scheme, as well as a summary report and tabular data. With the web-based version making data available at national level, users can retrieve the aggregate information and create a report by matching the irrigation scheme with the province, district, and irrigation scheme area. The data includes the type of the irrigation scheme, class and extent of irrigation area, and length of irrigation canals. The user can also perform attribute or spatial queries to locate the irrigation schemes according to details of the river basin, province, district and name. If the irrigation schemes are located on the map, the details of these schemes can be automatically retrieved from the ISSI tabular data holding.

## **Natural disasters and flood and drought monitoring**

The DGWR has collected reports about flooding and droughts from all provinces of Indonesia by developing institutional networks and using telephone and fax communications. On a national level, the staff of the flood and drought monitoring unit (Satgas) record and enter this information into the databank and report it to the Director General and Minister. The WRDC's data warehouse system prepared an application based on the existing system to provide tabular data linked to mapping reports, thereby adding value to existing information resources via enhanced functionality, as the tabular and spatial data are fully integrated in this application. In future, the application will increase in scope to add information about landslides and other natural disasters such as volcanic eruptions.

The flood and drought monitoring application provides easy access to the flood, drought and water-level data coming from selected hydrological stations network, as well as climate and rainfall data, by linking to the Meteorology and Geophysical Agency (BMG) report system which assists with disaster mitigation management. The application background is as follows:

Purpose of application: the purpose of this application is to maintain the data and to provide the information related to natural disasters, especially flood and drought events, which is a major problem for water resource management. It is used by specialists responding to crises and for forward planning. The application is to be applied in real time so as to incorporate data

coming from a regional reporting network at the time that flood events appear, for emergency services, and to identify the flood-prone areas for planning for disaster mitigation.

Data sources: the data available for this application are more intensively used for flood monitoring, as the data relating to the other natural disasters are not available yet in the WRDC system. The flood data are available for the whole of Indonesia from 1998 to 2003 continuously, collected from the Satgas of the DGWR – Ministry of SRI.

Output available: the users can get the specific information concerning the flood events based on the user requests through spatial or attribute queries. The data servers return the query results to the users in the report and map formats.

### **Water resources inventory**

This application is expected to become central to the system in terms of water resource management and development. It uses fully integrated map and tabular data and will be a first point of reference, providing ongoing support to all classes of work related to water resources. The application background is as follows:

Purpose of application: to hold, build and maintain the data and also to provide information related to water resources.

Data sources: the data are available for the whole of Indonesia, updated in 2000 and collected from the DGWR–Ministry of PW, covering rivers, swamps, lakes, reservoirs and small ponds.

Output available: users can retrieve specific information, as mentioned above, through spatial navigation, by using the maps button, the pre-designed query form and information button.

### **Hydrological infrastructure inventory**

The hydrological infrastructure inventory application provides background information related to the hydrological network stations in the rivers and lakes, as well as the rainfall and climate observation stations. The application presents the tabular data of the observing stations and, where possible, the summary statistics of the features measured. It also provides the contact details of the location and owner of the observing stations for users who need to access the fully detailed time series data records. The map data are fully integrated with the tabular data, so that the searches can be made from the maps and station details brought up for any location of interest. For future development, direct on-line access to these data will be achieved through linkages between the data warehouse and the specialist databases. For example, a link could be made to the hydrological databases which are currently being developed by the Sub-Directorate of Hydrology within the Ministry of SRI. The application summary is as follows:

Purpose of application: to maintain and provide information on hydrology and hydrometeorology infrastructures.

Data sources: the data available for this application are for the year of 2000, as supplied by the Capacity Building Project – Package 1<sup>2</sup>. The data pertains to eight provinces: West Nusa

---

<sup>2</sup> Capacity Building Project – package 1: Project on Water Resources Sector (under ADB Loan No.1339-INO). The aim of the Project is to support and strengthen activities in the Water Resources Sector by Developing the Water Resources Policies at Ministry of Public Works.

Tenggara, North Sumatra, South Sulawesi, South East Sulawesi, South Kalimantan, Maluku, Papua, and Bali).

Output available: the users can retrieve specific information, as mentioned above, through the spatial and attribute queries for the map serve. The pre-designed query form on the information page can be used to retrieve the specific station information in the tabular report format.

### **Other information**

The objective of the other information application is to provide the collection of other published and unpublished information that is of interest to people working in the water resources sector. It is also called a "soft-copy library". The sample data so far captured is limited just to the recent decrees and regulations as well as to the training material used for this application training. No source of soft-copy data was found during the project except for Project Training documents, and so all of the decrees and regulations have been entered into the system by typing from hard copies of the documents. The summary of the application is as follows:

Purpose of application: to maintain and provide the information about legal aspects, including the decrees, research documents, and the other relevant materials, of water resources.

Data sources: the data are supplied by DGWR – Ministry of PW.

Output available: users can download copies of the decrees, regulations and policy documents and training materials developed for the project.

### **File transfer protocol**

Purpose of application: to provide a tool that can be used to transfer data and files to and from the data warehouse.

Data sources: comprises the data holdings in the data warehouse system.

Output available: public users can download the free documents and tabular and spatial data held in the system. The extent of password protection will be at the discretion of the Ministry. The private users can download and upload the tabular and map data, insofar as they are authorized.

## **CONCLUSION**

Managing water resources is complex, and requires coordinated efforts between stakeholders. Capacity building and the gathering and sharing of relevant information are key aspects of achieving this. In Indonesia, this has been realized via a concerted effort that has begun to systematically store and make information available for users at the local, national and international levels. The water resources data management and warehouse system is a web-enabled application that permits spatial data to be stored with tabular data in a standard database management system. This system permits a dynamic generation of output from the tabular and spatial data and enables users to generate answers to their queries online, rather than simply presenting static maps and tables from the database.

The WRDC applications were developed and chosen by gathering the ideas suggested by users at the ministerial, provincial and district levels. Data and information such as the hydrological and water quality data, information of water resources potential, irrigation areas, population and economic growth as well as the others related data need to stored in both the tabular and spatial formats. So far, the system has proved extremely effective. It is anticipated that the data management system will continue to evolve in response to changing user needs, technical capabilities and improved capacities of users, in order to optimize coordination of information about water resource management in Indonesia.

## **REFERENCES**

Barmawi, M. and Amirwandi,S. 1999. 'Optimasi Pengembangan Sumber Daya Air Terpadu dalam Studi BTA-155 (Integrated Water Resources Development Optimization)', Water Resources Research and Development, Water Resources Conservation – Directorate General of Water Resources, Bandung, Indonesia.

Report of Capacity Building Project – Component 7. 2002. 'Water Resources Data Center', Water Resources Conservation – Directorate General of Water Resources, Jakarta, Indonesia.

Report of Capacity building Project – Component 1. 1998. 'MIS and Database Design of Water Resources', Water Resources Conservation – Directorate General of Water Resources, Jakarta, Indonesia.

Report of Java Irrigation Improvement and Water Resources Management Project. 1996. 'Basin Water Resources Planning Component', Water Resources Conservation – Directorate General of Water Resources, Jakarta, Indonesia.

Woodward, C. 1997. "WAS Initial Assessment Report", BPPT, Jakarta, Indonesia.



# EVALUATION OF THE PERFORMANCE OF CARBON DIOXIDE REMOVAL PROCESSES IN REVERSE OSMOSIS DESALINATION SYSTEMS

Assistant Professor Dr. Alaa' Abdulrazaq Jassim; Professor Dr. Saleh Ismial, Mahmood Shaker  
University of Basrah, Chemical Engineering Department, Basrah, Iraq;  
Email: alaaade992000@yahoo.com

## ABSTRACT

The aim of this paper is to compare two types of packing in order to evaluate the performance of carbon dioxide systems in distilled water produced from reverse osmosis desalination plants. The first conventional type of packing, Intalox Sadel, is compared to a second type of packing that use plastic pall rings. The subsequent concentration of the dissolved CO<sub>2</sub> gas is measured in terms of the different heights of packing and the influence of the packing height on the values of the mass transfer coefficient is also compared for both types of packing. The study thus seeks to mitigate negative externalities caused by carbon dioxide and oxygen, such as corrosion problems due to increased concentrations of these gases, and the influence of the dissolved gases on the pH values of water.

Testing was carried out in the reverse osmosis desalination plant at the University of Basrah's College of Engineering. A packed column comprised of a vertical vessel full of the packing medium stripped the dissolved CO<sub>2</sub> gas using air: a stream of air was pumped from the bottom of the column and a stream of untreated water was pumped from the top. The difference in pressure between the two streams enabled this process. The results revealed that the new type of packing was more efficient than conventional type due to the effect of the surface area of contact between the two phases (liquid and gas) on the rate of separation processes.

*Key words: reverse osmosis desalination, decarbonization, deaeration*

## INTRODUCTION

Varying amounts of free carbon dioxide (CO<sub>2</sub>) are present in natural waters. The amount of CO<sub>2</sub> absorbed by rain water from the atmosphere is very small, ranging from 0.5ppm to 2 ppm, whereas most surface water contains 0 to 5ppm of CO<sub>2</sub> and groundwater usually contains 1 to 50ppm of CO<sub>2</sub><sup>1</sup>.

A shortage of water in Iraq has caused the need for the application of desalination processes to harness other types of natural water for human use. However, this produces some negative externalities. The effects of gases dissolved in distilled water produced by desalination systems include, for example, corrosion problems due to increased concentrations of these gases, and likewise, the presence of the gases influence the pH values of the water. A separation process, called de-aeration or degasification, is therefore used to remove concentrations of corrosive gases such as oxygen, carbon dioxide, hydrogen sulfide or nitrogen that have been dissolved in distilled water.

Carbon dioxide (CO<sub>2</sub>) in water may be removed or reduced by means of an aerator, degasifier or vacuum deaerator and may be neutralized by the addition of lime or an alkali such as caustic soda, but these procedures are limited to raw or treated waters containing relatively small amounts of CO<sub>2</sub>. The performance of the deaerator greatly depends on the rate of water flowing through it and temperature of the water undergoing deaeration<sup>2</sup>. The packed column is useful in carrying out mass transfer

---

<sup>1</sup> Dara, S. S. A text book in engineering chemistry, water treatment, Chand company LTD, P.23, 1988.

<sup>2</sup> Belan F. I. *Water treatment*, Mir Publishers Moscow, 1981

between gas and liquid when the fluids are passed counter current flow<sup>3</sup>. A packed column consisting of a vertical vessel full of the packed medium has been used to strip the dissolved CO<sub>2</sub> gas via an air stream. The transportation process is achieved due to the difference in partial pressure between the two streams.

The mass transfer operation between the two is based on absorption theory, the concept of resistance, and heat transfer theory<sup>4</sup>. The relationship between the resistance of gas and liquid and the total mass transfer is expressed as follows [5]:

$$1/K_{G,a} = 1/k_{G,a} + 1/H.k_{l,a} = 1/H. K_{l,a}$$

$K_{G,a}$  and  $K_{l,a}$  are the overall gas and liquid phase coefficients respectively (based on a unit packed column) and  $k_{G,a}$  and  $k_{l,a}$  are the respective levels of resistance of gas and liquid mass transfer.

The application of this equation to the evaluation process is described in more detail in the section below.

## THE PROCESS DESCRIBED

The evaluation process for specifying the rate of carbon dioxide removal is realized using two types of packing undertaken at a pilot plant reverse osmosis desalination system. The plant has a capacity of about 9m<sup>3</sup>/h. The raw water is first treated by different chemical additives in the precipitator tank and the treated water then passes through sand, active carbon and cartridge filters before it is pumped to the membranes. The fresh water passes through the membranes while most of the dissolved salts are rejected. Lastly, a deaerator vessel is used to remove dissolved gases in the permeate water.

The permeate water is fed from the top section of the vessel and passes through the distributor. The feed water stream comes into contact with the air flow which is pumped by an air blower at the bottom of the deaerator vessel. The counter current flow is carried out through a vessel 0.75m wide and three metres long. The vessel is full of packing in order to increase the area of contact between the two phases (liquid and gas).

## RESULTS AND DISCUSSION

To specify the effect of packing height on the rate of CO<sub>2</sub> removal, a comparative study between the conventional and professional types of packing was realized.

The first type of conventional packing, namely Inteox Siddele, is used to decrease the concentration of CO<sub>2</sub> dissolved in water by pumping air from the bottom section of the column. The CO<sub>2</sub> concentration in the feed stream was about 2.99ppm. After the scrubbing process is carried out, the concentration of CO<sub>2</sub> was reduced to about 0.799ppm for a packing height of approximately two metres.

To increase the rate of CO<sub>2</sub> removal, a second type of professional packing, plastic pall rings, was used and its comparative efficiency gauged. A titration process using a sodium carbonate solution to specify the concentration of CO<sub>2</sub> in the effluent stream was conducted. The results proved that the rate of CO<sub>2</sub> removal increased by about 20 percent.

---

<sup>3</sup> Howe E.D. 1974. *Fundamentals of water desalination*, Marcel Dekker INC.

<sup>4</sup> Elmer L. & Charles F. 1953. *Vacuum degasification in a packed column*, Cem. Eng. Prog., v.49, no.8.

The packing height through the vessel is varied from (1.2-2.0m) and the concentration of CO<sub>2</sub> in the effluent stream is measured. Table 1 (below) shows the relation between the height of packing versus the values of CO<sub>2</sub> concentration for both types of packing.

Table 1: Effect of packing height on the CO<sub>2</sub> removal for both types of packing.

Height of packing (m)	CO <sub>2</sub> concentration (ppm)	
	Conventional type	Professional type
1.2	1.947	1.558
1.4	1.548	1.254
1.6	1.298	1.025
1.8	0.998	0.818
2.0	0.799	0.65

The results demonstrate that the efficiency of the professional pall ring type of packing is around 20 percent greater than that of the conventional type. The results proved that the increased area of contact between the two phases, obtained when the plastic pall rings are used, is considered to be the determining factor in improving the rate of CO<sub>2</sub> transfer from the liquid to gas phase.

## CONCLUSION

Removing gases dissolved in water production in desalination plants via optimal processes is considered one of the important methods for reducing the effect of corrosion problems through pipes and service tanks and for controlling the values of pH. Deaeration systems are used to improve the quality of desalted water.

For the purposes of this study, a scrubber column filled with the two types of packing was used and the efficiency of the column was measured to identify the best means of reducing the concentration of carbon dioxide dissolved in distilled, desalted water.

The study proved that the efficiency of the plastic pall rings of packing is greater than the conventional type of packing due to the effect of the surface area of contact between the two phases (liquid and gas) on the rate of separation processes. The rate of CO<sub>2</sub> transfer is increased by around 20 percent when the second professional type of packing is used.

# WATER REUSE: AN OVERVIEW

Prof. Dr.-Ing. Peter Cornel and Dipl.-Ing. Barbara Weber, Technische Universität Darmstadt, Germany  
Email: p.cornel@iwar.tu-darmstadt.de

## ABSTRACT

This paper describes some aspects of water shortages, particularly in relation to food production. Out of different measures used to overcome water shortages, water reuse for irrigation and as service water has become of particular interest. By using treated wastewater for agricultural irrigation, the nutrients - namely nitrogen and phosphorus - serve as fertilizer. However, large water demands combined with high nutrient concentrations can lead to over-fertilization and could negatively affect groundwater quality. Thus the nutrient content can be a limiting factor for the used amount of treated wastewater for irrigation.

To overcome this problem, this paper shows how wastewater treatment plants can be operated differently in summer – where the water is reused as irrigation water – and winter, where nutrient removal may be required to protect the receiving water body. Furthermore, it is shown that adequately treated wastewater can be reused as service water, such as for toilet flushing. Such inner urban water reuse fosters the instigation of semi-centralized treatment and supply centres which combine the advantages of conventional centralized systems - such as professional operation and maintenance, monitoring and compliance - with high quality standards and the use of advanced and energy-efficient technologies. Additional advantages include higher flexibility and sustainable reuse of water as proposed for decentralized systems.

## INTRODUCTION

Whereas the annual per capita water requirements for households, services and industrial activities averages 25 m<sup>3</sup> in Africa, 232 m<sup>3</sup> in Europe and 366 m<sup>3</sup> in USA, the overall annual amount of water per person can only be called sufficient when it exceeds 1,700 m<sup>3</sup>. This apparent gap is caused by the amounts of water necessary for food production. To calculate, Zehnder [2003] provides some general guidelines: for 1 kg of bread, 1 m<sup>3</sup> water is needed and ten times more water is needed per unit of energy from meat than from plants.

Thus, to cover 2,500 kcal per day per person, 500 – 1,000 m<sup>3</sup>/a is actually needed for vegetarians and 1,200 – 1,500 m<sup>3</sup>/a for carnivores, equivalent to 20 percent of energy derived from meat. This leads to the following classification of the annual per capita water requirements [Zehnder, 2003]:

Sufficient	> 1,700 m <sup>3</sup>
Water stress	1,000 – 1,700 m <sup>3</sup>
Scarcity	500 – 1,000 m <sup>3</sup>
Extreme scarcity	< 500 m <sup>3</sup>

The renewable water per capita in Iran was 1,830 m<sup>3</sup>/a in 1996, but in 2020 will be only 1,200 m<sup>3</sup>/a [Mahmoodian, 2001]. Considering these figures it is likely that Iran might suffer from a lack of water in future and in fact, in some regions of Iran water scarcity is already a problem today.

## OPTIONS

To solve the water shortage problems, a number of different measures are proposed, including:

- integrated water resource management, that incorporates sustainable, ecological and economical aspects;
- more efficient water use;
- importation of water from external sources as “virtual water”, whereby importing 2 kg wheat replaces 1,000 L water;
- use of additional sources such as: runoff water / “rainwater harvesting”, saline water / sea water and treated wastewater / water reuse.

As described, water reuse options are manifold. Adequately treated wastewater may be used for irrigation, in aquaculture, as service water in industry and households, for ground water recharge or even - after high tech multi barrier treatment - to produce potable water , as, for example in Windhoek, Namibia.

The following section of this paper will now focus on agricultural reuse for irrigation and reuse as municipal service water.

## QUALITY REQUIREMENTS AND STANDARDS

Water reuse quality requirements are determined by the desired purpose or final use of the treated water and can be categorized according to short and long term aspects. In the short term, factors to be considered include: the health protection of farmers and users (pathogens, etc), acceptance by users (smell, taste, colour, etc), quality demands of plants (salt concentration, nutrients, etc) and technical issues (clogging, corrosion). In contrast, long-term environmental considerations like groundwater protection (nitrate, oxygen depleting compounds) and soil protection (salts, nutrients, heavy metals) must be considered.

Further, for irrigation purposes, the following compounds are of concern:

- pathogenic viruses, bacteria, protozoa and helminthes
- salts (especially Na-salts)
- plant nutrients (nitrogen, phosphorus, potassium)
- trace nutrients (copper, iron, zinc)
- trace elements
- inorganics (heavy metals)
- organics (endocrine disrupters, antibiotics, halogenated compounds).

Whereas microbiological recommendations for agricultural irrigation water indicated by the World Health Organization [WHO, 1989] distinguish three different quality standards for irrigation water and categories for different agricultural applications, the chemical and physical requirements stipulated by the Food and Agriculture Organization of the UN (FAO), specifies salinity, sodium and chloride concentrations or the content of Boron and other compounds to protect soil, plants and ground water.

For the reuse of water as service water, less regulations and recommendations are available, but some general principles apply: the water should be free of pathogens to protect public health; free of colour or smell so as to enhance acceptance by users; and low in suspended solids to protect the technical systems. Other specific requirements might also apply, depending on and differing between countries and states.

## AGRICULTURAL IRRIGATION

Agricultural irrigation has by far the highest water demand, totalling about 70 percent of the world's water demand. As water availability and demand may differ regionally because of different climates, irrigation water demand depends on different local kinds of plants, soil and irrigation techniques. In relation to irrigation, for example, this could mean flood irrigation, sprinkler irrigation or drip irrigation.

As irrigation water is basically only needed during vegetation periods, the demand varies seasonally. Thus year-round water reuse requires large storage facilities. Natural, above-ground storage is impeded by high evaporation losses and, as a result, an increase in salt concentration. Sub-surface storage, for example storage in the aquifer, requires high water quality to prevent groundwater pollution.

Water reuse for irrigation allows the reuse of the wastewater's nutrients. The nutrient concentrations (N, P) may be the limiting factor for a specific amount of water [ $\text{m}^3/(\text{ha}\cdot\text{a})$ ]. The necessary removal of nutrients from water used for irrigation is controversial: whereas some countries remove nutrients from wastewater, others use the nitrogen and phosphorus it contains as fertilizers. The latter option leads to different treatment objectives throughout the year: within the irrigation periods, nutrients could remain in the treated water, but outside the irrigation period the water must be treated for its disposal or for subsurface storage, thus nutrient removal may be required. In the following section, some aspects of nutrient treatment and water demand are first given. A concept for a wastewater treatment plant with different seasonal operation modes is then introduced.

## NUTRIENTS

Wastewater contains major plant nutrients (nitrogen, phosphorus and potassium) and also trace nutrients (such as copper, iron and zinc). In Germany, total nitrogen concentrations in raw wastewater are usually about 70 mg/l and phosphorus concentrations are about 11 mg/l for a water consumption of 150 l/(PE·d). In wastewater treatment plants (WWTP) without nutrient removal, the effluent concentrations are about 50 to 54 mg/l for ammonium-N (loss of 3 mg/l by settling in the preliminary clarifier and 0.02- 0,025-mg/mg COD-concentration by incorporating into bio-mass) and about 7 to 8 mg/l for phosphorus [ATV-DVWK A 131/2000]. In treatment plants with nutrient removal the inorganic N-concentrations are between 10 and 15 mg/l and the phosphorus concentration is below 0.5 to 1 mg/l depending on the size of the treatment plant.

In Germany, an agricultural area of only 237,000 ha (47 percent of the total agricultural area with irrigation equipment (500,000 ha) in Germany) was irrigated in 1998 with 163 Mio  $\text{m}^3$  [Statistisches Bundesamt 2001], thus the average water consumption was 688  $\text{m}^3/(\text{ha}\cdot\text{a})$ . With this specific amount and the above-mentioned concentrations of 50 to 54 mg N/l and 7 to 8 mg P/l, it is possible to fertilize while irrigating with about 36 kg N/( $\text{ha}\cdot\text{a}$ ) and 5 kg P/( $\text{ha}\cdot\text{a}$ ), which seems to be only a small amount of the needed quantities of 170 kg N/( $\text{ha}\cdot\text{a}$ ) and 26 kg P/( $\text{ha}\cdot\text{a}$ ) [Könemann 2003].

But this average number is misleading. Even in Germany – where, in general, there is seldom the need for irrigation – the maximum reported is a specific irrigation water amount of 5,500  $\text{m}^3/(\text{ha}\cdot\text{a})$  which translates in about 285 kg N/( $\text{ha}\cdot\text{a}$ ) and approximately 43 kg P/( $\text{ha}\cdot\text{a}$ ), for which the soil would have been fertilized with nitrogen and phosphorus, with the risk of nitrate entering the groundwater.

Thus the ratio between water and nutrient demand is important and has to be considered and controlled. In that respect, the different needs of different plants is important. Table 1 depicts some annual nitrogen and phosphorus application rates for a variety of fruits and vegetables.

Table 1: Annual nitrogen and phosphorus application rate in kg/ha

(Ruhr-Stickstoff AG 1988) [1 kg P<sub>2</sub>O<sub>5</sub> = 0.436 kg P]

Culture	Nitrogen-N	Phosphate P <sub>2</sub> O <sub>5</sub>	Phosphorus-P		
wheat rye	100-210	50-100	22	-	44
corn	60-160	50-100	22	-	44
potato	120-180	100-150	35	-	66
sugar beets	100-140	90-140	39	-	61
red cabbage, cauliflower	140-210	90-140	39	-	61
kale	160-250	80-100	35	-	44
tomato	120-180	60-80	26	-	35
apple	20-150	0-50	0	-	22

Depending on the climate, plant, soil and irrigation system, it is possible to substitute the whole fertilizer demand by using treated municipal wastewater for irrigation. Hence it is important to treat the wastewater for irrigation use according to the regional and seasonal conditions and in order to avoid fertilizer entry into and contamination of the groundwater body.

## ACTVATED SLUDGE TREATMENT WITH SEASONALLY ADJUSTED OPERATION MODES

### General considerations

Although a number of different possibilities for wastewater treatment exist, the following section will focus on the activated sludge process. It will be shown that different operation modes in summer and winter might be advantageous for the production of treated water suitable for agricultural reuse in summer and meeting effluent stringent effluent standards in winter. Although a variety of different water quality parameters must be observed, the following section will focus only on the nutrient nitrogen.

Thus, according to this idea of different operation modes in summer and winter, the mechanical treatment - consisting of screens, grit chambers and preliminary clarification - remains unchanged in conventional wastewater treatment plants. A short, preliminary clarification time (30 to 45 min) is advantageous when denitrification in wintertime is required. Chemical precipitation of phosphorus rather than enhanced biological phosphorus removal (EBPR) is recommended, considering the higher flexibility and the slower re-start of its enhanced biological P-removal. Because of the very slow growth rate of the nitrifying bacteria, a special operation mode is compulsory. As different seasonal operations of wastewater treatment requires three or more parallel trains, it seems to be suitable only for large treatment plants that service more than 100,000 people

### Example: wastewater treatment plant

Here the example treatment plant is designed for 500,000 population equivalents (PE), a flow rate of 75,000 m<sup>3</sup>/d and loads after primary sedimentation of 22,500 kg BOD/d, 45,000 kg COD/d and 5,000 kg N/d. The MLSS-content in the activated sludge tank should be about 3.5 g/l. The treatment plant was designed in accordance to the German guidelines for municipal wastewater treatment [ATV-DVWK A 131 2000 ].

The treatment plant was designed to ensure that N-removal could be achieved at temperatures down to 12°C. For the activated sludge tanks, a total volume of 60,000 m<sup>3</sup> is calculated (20,000 m<sup>3</sup> for denitrification, 40,000 m<sup>3</sup> for nitrification) with a 'sludge age' (sludge residence time) of 9.5 days at 12°C. The wastewater treatment plant has three equal lines (trains In summer months at water

temperatures greater than 18°C and without specific N-removal, a sludge age of less than two days would be sufficient, which would result in an aeration tank volume of less than 12,600 m<sup>3</sup> by a MLSS-content of 3.5 g/l (Figure 1).

Figure 1: Sludge residence time (SRT) vs. water temperature,  $V_{\text{anoxic}}/V_{\text{total}} = 0,66$

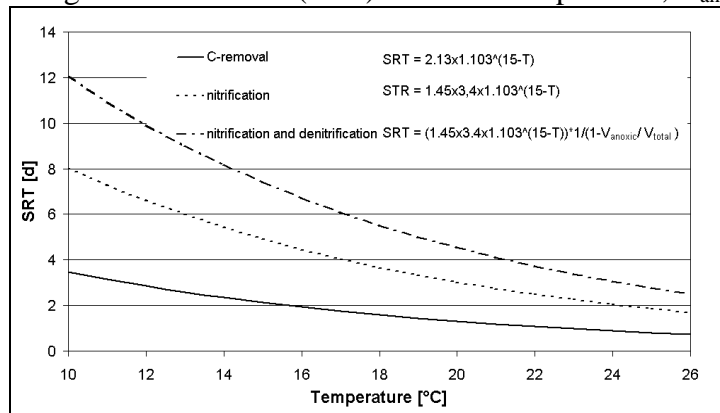

Figure 1 shows the minimum sludge residence time (SRT) or sludge age for nitrification and nitrification/denitrification at different temperatures, according to the standard established by the German Association for Water, Wastewater and Waste [ATV-DVWK A 131 2000]. The added correlation for “C-removal” characterizes the sludge residence time that is long enough for an almost complete C-degradation but short enough to avoid nitrification. This correlation was calculated using the reciprocal growth rate for the nitrifying bacteria.

With respect to seasonal, in principal two operation modes are possible:

- operation with N-removal by operating all lines at sludge ages above the required minimum sludge age for nitrification/denitrification
- operation without nitrification/denitrification at sludge ages according to the solid line in Figure 1

The main challenge is the transition between the two operation modes, thus restarting N-removal after several months without nitrification. The lack of nitrifying bacteria will prevent a fast re-start of nitrification because of the slow growth rate. Therefore it is suggested to keep the nitrifying bacteria in one line (line 1) by operating this line together with nutrient removal, whereas line 3 is shut down and line 2 is operated at a low sludge age to remove just the organics without nitrification. The third line (line 3) can be used as a storage tank for treated water to equalize the daily fluctuations in inflow and water demand as well as reaction-zone for disinfection (see Figure 2 below).

Thus, during the vegetation period, the Wastewater Treatment Plant (WWTP) is operated as follows:

- Line 1: with nutrient removal (Removal of C, N and P (optional))
- Line 2: without extra nutrient removal (only C-removal)
- Line 3: storage, equalization and reaction zone for disinfection (optional)

To enable the described operation modes, independent controllable lines are required, each with its own recirculation of return sludge.

One of the advantages of such an operation mode is that different nitrogen and phosphorus concentrations can be reached by mixing the effluents of line 1 (low in N as nitrified and denitrified and optional low in phosphorus when operated with P-removal) and line 2 without any extra N- and



P-removal . Thus a desired fertilization by blending the effluent of the two lines is possible. In Figure 2 (below) such a plant scheme during the vegetation period is shown.

Figure 2: Operational mode in vegetation period

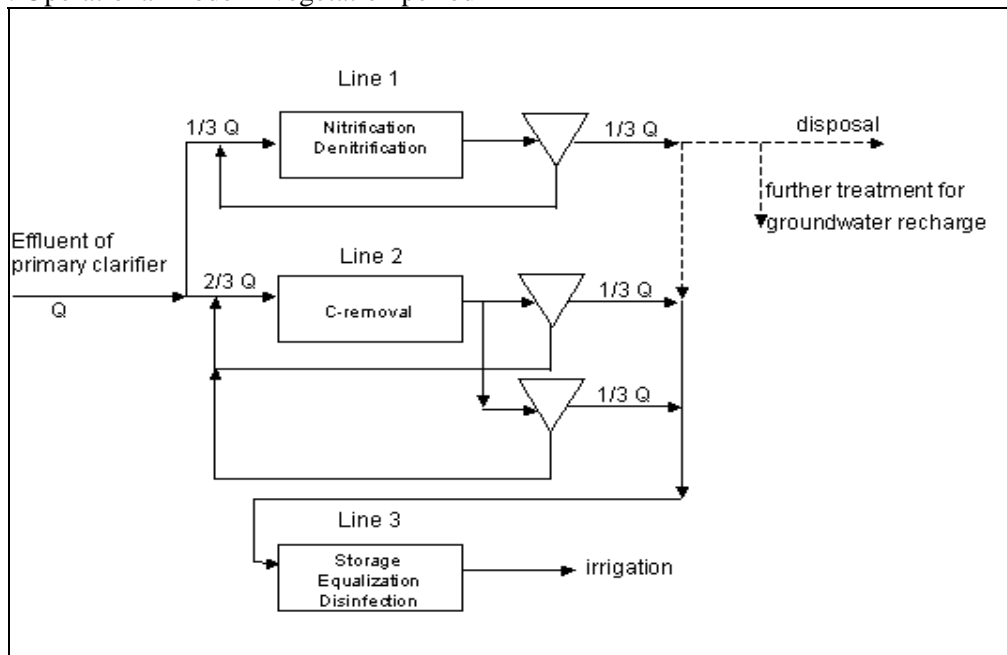

Three lines are enough to achieve the operational adjustments. Line 1 (with a MLSS-concentration of 3.5 g/l) receives one third of the inflow and line 2 comparatively receives two thirds of the inflow with a MLSS-concentration of about 2.5 g/l. The calculated effluent concentrations for ammonium-N and nitrate-N are 2 mg/l and 8 mg/l, based on pre-denitrification with a recirculation rate of 4.2 in line 1 and 43 mg NH<sub>4</sub>-N/l and 0 mg NO<sub>3</sub>-N/l in line 2 (calculated with ASM 1). The more lines there are the more flexible and appropriate the operation mode can be for a given situation.

After the irrigation period, the operation mode has to be switched to N-removal in all three lines. This comprises two steps. First, line 3 has to be put back to operation by:

- transferring surplus sludge from line 2 for two to three days in tank 3 while aerating
- reconnecting the secondary clarifier to line 3 and feeding line 3 with one third of the influent

After these measures, lines 2 and 3 have a MLSS concentration of about 2.5 kg/m<sup>3</sup>. For example, this is enough for C-removal, but with very little or no concentration of nitrifying bacteria. Comparatively, line 1 remains unchanged by nitrification and denitrification. Secondly, lines 2 and 3 have to be enabled for N-removal as described below.

The fastest way to increase the population of nitrifying bacteria is to transfer the daily excess sludge from line 1 to lines 2 and 3 for about 10 days.

This example shows that seasonally adjusted treatment offers the possibility to adapt the water qualities to the required goal in an ecologically sustainable and economically affordable way. Similar concepts exist for other demands, for example, for those plants where denitrification is not required because water is not used or stored in winter, and thus the effluent standards for receiving water do not require total N-elimination.

## WATER REUSE AS SERVICE WATER

The use of service water instead of potable water directly reduces drinking water consumption and contributes to the conservation of natural resources and a reduction in costs for long distance pipelines and water treatment. Water reuse is inevitable not only in arid and semi-arid areas, but also in all rapidly growing regions and megacities where local demand always exceeds local supply.

Service water can replace about 35 to 45 percent of the drinking water in households (e.g. for toilet flushing, garden irrigation, air conditioning), all irrigation water within the cities (as in residential areas, road planting, parks, sport fields, golf courses), as well as water used for small industries, car washing, road cleaning or fire protection. The overall savings of drinking water could be as high as 50 percent. As water availability and demand are synchronic in space and time, its reuse therefore requires only small storage spaces.

Potable water reuse as service water leads to decentralized systems because it fosters:

- higher flexibility and incremental growth (modularization)
- shorter distribution and collection systems
- better overall economy
- the separation of industrial and municipal wastewaters
- dual supply of potable and reclaimed, non-potable water
- dual collection systems (optional)
- individual awareness of water origin.

However, the size of decentralized units may differ according to different categorizations which each have different corresponding figures, as indicated below:

household	< 10-20 Population Equivalent (PE)
cluster	< 1,000 PE
housing developments	> 1,000 PE
commercial, residential facilities	1,000 – 10,000 PE
satellites, suburbs semi-decentralized	10,000 – 200,000 PE

As a household-based system will be presented at this conference, the idea of a semi-decentralized supply and disposal center will now be explained. This innovative, new concept - currently under development - links the different fields of infrastructure (water, wastewater, waste, energy, heat) in semi-centralized, town/district-based supply and disposal facilities. The combined treatment offers new technical possibilities such as mass and energy flows within the facilities e.g. the co-treatment of organic wastes and wastewater or residuals of wastewater treatment and the direct use of biogas or heat for distribution or generation of electricity.

The result is a more efficient system and less residues to be disposed of. Short pipes between locations of the consumer and wastewater treatment are more economical and offer the possibility of economical water reuse. Treated wastewater can be discharged to the next receiving water body or reused for inner urban irrigation without any need for long-distance transportation out of town. Nearby waste treatment facilities minimize traffic and optimize the recycling of resources. Further, supply and disposal are conducted by qualified personnel thus maximizing safety to achieve good and reliable quality standards, hygiene in water distribution and water reuse, and surveillance of material flows and disposal.

The optimal size of such semi-centralized facilities in urban areas might service a population in the range of 20,000 to 200,000. This depends on variables such as specific water consumption and amount of waste, requirements for reuse, demand for heat and cooling energy and existing infrastructure. It is also influenced by population-density, financing structure, system of payment and charges and others.

Figure 3      Black-box model for an integrated semi-decentralized supply and disposal center

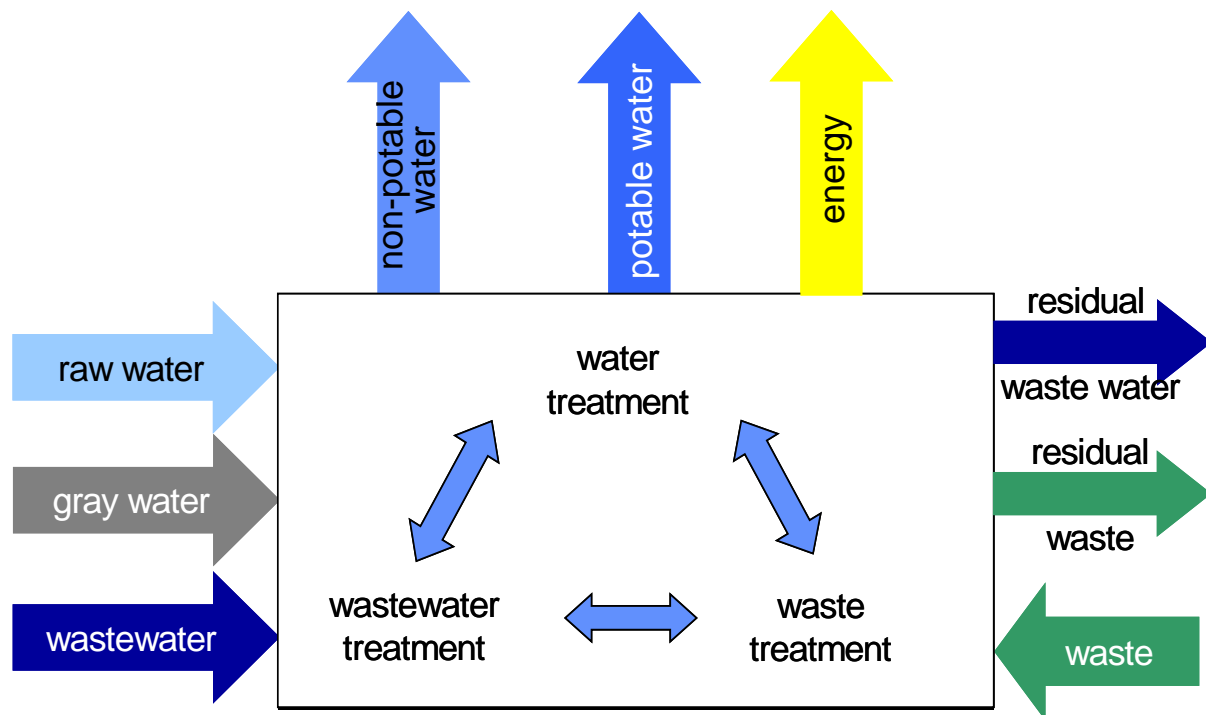

The advantages of this system compared to conventional centralized systems include:

- more sustainable reuse of water; the possibility of splitting of industrial and municipal wastewater;
- feasibility of dual piping;
- higher flexibility (planning, technical adaptation on specific conditions);
- better overall economy (water treatment and supply, sewer system, wastewater treatment waste disposal)
- incremental growth (modularization); and
- users'/ customers' individual awareness and responsibility of customers of the waters origin and different qualities of portable water and service water.

Compared to decentralized systems (on the household level), the following advantages might be claimed:

- more professional operation and maintenance
- monitoring and compliance of quality standards
- use of advanced and energy efficient technologies
- holistic approaches to water, wastewater and waste management

## CONCLUSION

To solve local and global water scarcity, an integrated water resource management, efficient and customized use of the water resources and importation from external sources as 'virtual water' is needed. From various different options for the reuse of water, its reuse for agricultural irrigation and as municipal service water has been addressed. The water quality standards depend of course on the reuse application. Besides short-term quality parameters to protect workers and users, long-term environmental aspects like groundwater and soil protection have to be considered when reusing water for irrigation applications.

Agricultural irrigation has by far the highest water demand. As the nutrients contained in wastewater can be used as fertilizer, a balance of nutrient and water demand is inevitable. Salt and especially the

Na<sup>+</sup>-concentration might be a limiting factor in order to avoid negative impact on plants and soil. As irrigation and fertilization periods are limited to vegetation periods, WWTP should be operated seasonally, using the nutrients in vegetation periods and removing nutrients to protect the environment in the wintertime.

Water reuse as service water leads to decentralized systems because it fosters:

- higher flexibility and incremental growth (modularization)
- short distribution and collection systems
- better overall economy (cost-saving benefits)
- separating industrial and municipal wastewaters
- dual supply of potable and reclaimed, non-potable water
- dual collection systems (optional)
- individual awareness by users.

The degree of decentralization differs from household-based systems (< 10 - 20 Population Equivalents (PE)) to satellites and suburbs of 10,000 – 200,000 PE (semi-decentralized). Semi-decentralized supply and disposal facilities in particular seem to constitute a sustainable, flexible and holistic approach. They combine the advantages of conventional, centralized systems - such as professional operation and maintenance, monitoring and compliance - with high quality standards and the use of advanced and energy-efficient technologies. They also provide more flexibility, better overall economic value and the same sustainable reuse of water as that proposed for decentralized systems.

## REFERENCES

Asano, T. 2001. 'Water from (waste)water - the dependable water resource', paper for the 2001 Stockholm Water Prize Laureate Lecture, 13.08.2001

ATV-DVWK A 131 2000. *Design of Activated Sludge Plants*, Manual, A 131, ATV-DVWK-Regelwerk, Gesellschaft zur Förderung der Abwassertechnik e.V. GFA, Hennef, Germany

Ayers, R. S., und D. W. Westcot 1985. 'Water quality for Agriculture', FAO Irrigation and Drainage Paper 29 Rev., Food and Agriculture Organization of the United Nations, Rome

Cornel, P. Weber, B. 2003, 'Water Reuse For Irrigation From Waste Water Treatment Plants With Seasonal Varied Operation Modes', IWA 4th International Symposium On Wastewater Reclamation And Reuse, November 12-14. 2003 Mexico

Cornel, P.; Weber, B. 2003, 'Decentralized Sanitation Concepts for Urban Areas', Seminar Achema Frankfurt (GER); May, 2003

Cornel, P. 1999, Möglichkeiten der Wiederverwendung von Abwasser – ein Überblick, WAR Schriftenreihe 116, Abwasserwiederverwendung in wasserarmen Regionen

Ghassemi, Ali. "Periods of Water Crisis in Tehran - Causes, Strategies and Outcomes"; TWW Co. (year and place of presentation unknown)

Mahmoodian, Syed Ali 2001. "Water from Water (A review of wastewater reuse in Iran)"; Paper presented at a FAO/WHO conference in Jordan, November 2001

Ministry of Construction, PR-China 2001. Water Quality Standard, CJ 25.1-89; in Nie, Mei-shen, *Handbook for Water Industry - Engineering, Design, Water Resources and Treatment*, China Architecture and Building Press, p. 109

Pescod, M. B. 1992. Wastewater Treatment and Use in Agriculture, *FAO Irrigation and Drainage Paper 47*, Food and Agriculture Organization of the United Nations, Rome

Ruhr-Stickstoff Aktiengesellschaft 1988. Faustzahlen für Landwirtschaft und Gartenbau, Landwirtschaftsverlag GmbH, Münster-Hiltrup, 11. Auflage

Sen Bau Wohnen 1995. Merkblatt ‚Betriebswassernutzung in Gebäuden‘, Senatsverwaltung für Bau- und Wohnungswesen Berlin, 1995

Statistisches Bundesamt 2001. 163 Mill. m<sup>3</sup> Wasser für künstliche Bewässerung in der Landwirtschaft, Mitteilung für die Presse, 13. February 2001  
<http://www.destatis.de/presse/deutsch/pm2001/p0490155.htm>

WHO 1989. ‚Health Guidelines for the Use of Wastewater in Agriculture and Aquaculture‘. Report of a WHO Scientific Group, *Technical Report Series 778*, Geneva, Switzerland

Zehnder, A. J. B.(EAWAG, CH) 2003. ‚Global shortage of Water Resources: Needs and Technological Perspectives for Closing the Water Cycle, Seminar Achema Frankfurt (GER); May, 2003

[www.iwar.bauing.tu-darmstadt.de](http://www.iwar.bauing.tu-darmstadt.de)

# MEASURES TO MINIMIZE WATER CONSUMPTION AND WATER LOSSES - CASE STUDY OF BERLIN

Bernd Heinzmann, Berlin Water (Berliner Wasserbetriebe), Germany; Email: bernd.heinzmann@bwb.de

## ABSTRACT

This paper describes how the sociological, economic and technical aspects of water consumption - such as consumer attitudes, tariff systems and the availability of water saving equipment - have shaped methods for the reduction of water consumption in Berlin. Examining Berlin as a case study shows how public relations activities and the application of a strategy for the evaluation of the leakage losses in the pipe network have drastically reduced water consumption. Whereas before, leakage losses and water losses were identified by prophylactic, spontaneous searches throughout the whole city area, this has changed to a more systematic approach. According to this new approach, using a database that registers the pipe network, a decisive search of leakage losses is enabled, particularly in those areas with high damage rates. Thus, over 10 years, the Berlin Water Works succeeded in achieving a considerable reduction of the water losses caused by breakages in the pipe network, from about 25 percent to around 4.5 percent. Further, in the eastern part of Berlin, household water consumption was reduced by around 50 percent, from around 250 litres per capita per day to about 125 litres per capita per day. The findings from the water-saving activities undertaken in Berlin can be framed as recommendations for similar situations in emerging countries or in those countries with water scarcity.

## INTRODUCTION

Water is a prized resource throughout the whole world: everyone needs and consumes water every day, for drinking, washing and cleaning, for example. Water consumption could be measured as the quantity of water actually taken from water main equipment during a certain time period, be it for consumer use or due to leakage and loss. Consumption rates vary between different regions of the world: whereas a North American uses on average 500 litres of water per day, a Western European uses an average 150 litres and an African only 50 litres per day. Such variations are also attributable to socio-demographic factors such as age, lifestyle, income and location: young and old people use less water than the average person, people with more disposable income can more easily pay for and therefore use more water, and rural dwellers tend to use less water than city dwellers. Further, the amount of available water also governs usage patterns, as water is more available in some locations, like North American urban conurbations, than others, like in desert areas in Africa. Other relevant considerations include water price, settlement structure, hygiene standards, the availability of water saving tools for households, and commercial and industrial usage.

Saving water thus depends on the specific situation and the existing available infrastructure. In most cases, high levels of water use cause both environmental and economic problems. From an environmental perspective, high consumption places stress on rivers, lakes and groundwater aquifers, and may cause dams to flood. All of these effects can seriously affect the local ecology. Also, the discharge of polluted, used water damages aquatic ecosystems. From an economical perspective, high levels of water use require ever-increasing and expensive investments in water system infrastructure needed to gather, deliver and dispose of water (dams, reservoirs, water treatment facilities, distribution networks and sewage treatment).

In cases of the existing infrastructure designed for higher water consumption in some developed countries like Germany, decreased consumption results, for example, in iron deposits in the pipe network or sediments and odour problems in the canalisation system.

To examine some of these problems associated with water shortages and high levels of water use, this paper uses Berlin as a case study. Specifically, two aspects of water management are addressed: first, the importance of public relations activities to change user behaviour and attitudes in relation to water use; and second, the need to identify technical weaknesses such as leakages in order to improve the systemic efficiency of water management. Specific techniques and activities are listed in corresponding sections throughout the paper. Further, a comparison over ten years, starting with the 1980s, and continuing to the 1990s, is outlined in the following sections.

## **STARTING POINT: THE 1980'S**

Berlin is located between the Barnim and Teltow plateaus, in the Warschauer glacial valley and was crossed by channels and lakes created during the ice-age. The sandy soil of the region provides favourable hydro-geological conditions for water supply. In the glacial valley sections there exist predominantly quaternary and tertiary sediments. The bacteria and viruses are eliminated during the subsoil passage.

As a consequence the western part of Berlin has been able to sustain its own water supply for several decades based on these following principles of water supply:

- The water supply is provided from the regions' own resources. The water supply is self-sufficient and self-sustaining in the Berlin region.
- The resources consist exclusively of groundwater, which consist of natural and artificial groundwater and bank filtered water.
- Artificial groundwater recharge is an important part of water resources management in the Berlin region.
- The water supply system incorporates a simple drinking water treatment: water intake - aeration - manganese and iron removal - filtration.
- A close-to-natural water treatment process without chemicals can be maintained.
- No disinfection of the drinking water is required (very few cities in Germany deliver drinking water without disinfection).
- Provisions for careful maintenance of the water-pipe network are necessary.
- In order to meet quality standards stringent precautionary measures for water resource management (groundwater and surface water) are undertaken.

However, in the Cold War context of the 1980's Berlin, was a city divided into East and West. In both parts of the city drinking water was provided for the customer by separate pipe networks through separate enterprises. For political reasons, the highest priority for the western part of the city was to ensure autonomous water supply in the urban West Berlin area. This was coupled with a commitment to undertake public relations activities for improved water resource management. Some aspects of West Berlin's water resource strategy are examined in the following section.

## **EARLY PUBLIC RELATIONS ACTIVITIES: WEST BERLIN**

Since 1980, activities have been ongoing for the instruction of the Western Berlin population in order to effect a sensible and conscious attitude amongst the population towards the environment and in particular, to water. And to protect water resources and reduce contamination of surface water and groundwater to ensure an adequate quality and quantity of drinking water supply.

A number of methods were therefore utilized, focused on publicity and public relations, with specific tactics implemented, as listed below.

## **Publicity Campaign**

- Distribution of stickers to the customers with proclamations like: ‘think about water’, ‘do not transform the toilet into a garbage can’
- Posters in the public transport system (MRT, bus, tram, city trains)
- Distribution of leaflets like ‘car washing in Berlin’

## **Public relations and public instruction**

- Development of a culture for a friendly relationship with the user / customer
- Guided tours in the water works to help create an image of accessibility
- Instruction about water use and management in kindergartens and schools
- Enhanced teacher education about water management (multiplication effect).

## **REDUCTION OF WATER CONSUMPTION IN BERLIN IN THE 1990’S**

### **The water supply situation in Berlin after Reunification (1990)**

Comparatively, in the former German Democratic Republic (East Berlin), the attitude of the customers was determined by a subsidizing policy that led to a waste of water and energy. Thus, the situation after the fall of the wall in the eastern part of the city was characterised by:

- extremely high water consumption;
- high water losses caused by the obsolete pipe network due to insufficient maintenance;
- expensive treatment technologies, again caused by insufficient maintenance of the wells and inadequate protection of the resources.

The situation was catastrophic, precipitating a special need for advice and education of the customers in the eastern part of the city. Furthermore, the pipe breakage rate was about 0.2 to 0.25 damages per kilometre per year, a rate much higher and trending upwards compared with the western part of the city (about 0.05 to 0.1 damages per kilometre and year) as you can see in Figure 1. The main reasons for this considerable difference in relation to water pipes were the selection of materials, quality of pipe-laying and pipe maintenance (or lack thereof).

To further complicate the situation, the prognosis given after reunification predicted an increase of the population from 3.4 million to 5 or 6 million inhabitants, causing a corresponding raise in the demand for drinking water. Thus, it was necessary to:

- intensify the already ongoing activities for water saving in the western part of Berlin that had been in place since the 1980’s;
- extend these activities especially to the eastern part of the city (note: the results of the development of specific water consumption in households can be seen in Figure 2); and
- develop an integrated concept for environmental protection and for a sensible water-saving campaign.



Figure 1: Trend and pipe breakage rate in damages per kilometre and year

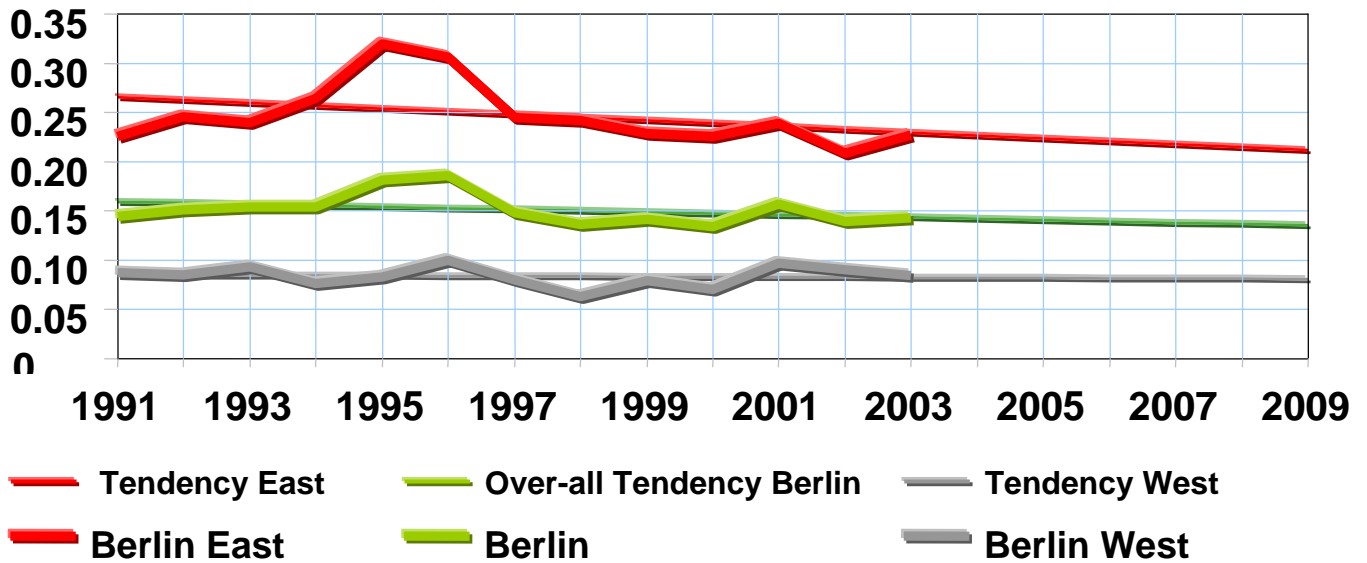

Figure 2: Water consumption in household and industry in liters per day and per capita



## MEASURES FOR THE REDUCTION OF WATER CONSUMPTION IN BERLIN

With the end of the Cold War, the changing political climate over the course of the 1980s also heralded an opportunity to address water resource management in a more holistic fashion. In consideration of the sociological, economic and technical aspects of water consumption, such as consumer attitudes and behaviour, tariff systems and the availability of water saving equipment, some methods for improved water management are outlined briefly below. These were employed by the Berlin Water Works (Berliner Wasserbetriebe) to help limit water consumption and water loss. Further information about the technical rules governing water consumption can be gleaned from the regulations of the DVGW (German Association for the Gas and Water Field).

### ***Economic aspects***

- Tariff system: instigation of a system for charging the customers for individual water consumption
- Financial support of water saving measures by the authorities (city, country, water supply companies).

### ***Technical measures***

- Temporary subsidies for the installation of water saving devices
- Development of water saving devices and apparatus by the industry and

### ***Making technology available to consumers***

- Valves on water taps in hand-basins, showers and in the kitchen
- Installation of flushing pans with low water filling water quantities
- ‘Stop-and-go’ push buttons for the water flushing pans in the toilets
- Flow velocity stabilizers
- Contact-free armatures
- Vacuum toilets
- Installation of domestic water meters
- Development of suitable strategies for the installation of water meters (e.g. at first in selected areas/districts with great water losses) – promoted in home building strategies.

### ***Measures undertaken in the pipe network***

- Implementation of a public strategy for the detection of leakage losses: analysis of water losses, preventive search for leakages
- Establishment of databanks to monitor the pipe network, especially damage statistics, based on public information
- Strategy for the upkeep of the pipe network (maintenance, overhauling, inspection).

### ***Public awareness research***

- Consideration of the readiness and attitude of the inhabitants and the carriers of the public management concerning the installation of water meters and water saving in general
- Public relations management via the selection of appropriate methods for different locations in accordance with boundaries, including information and instruction
- Explaining to customers the need to introduce payment tariffs or for increasing these fees prior to their establishment by the public management.

### ***Public relations activities***

- Customer information about water saving (explaining the reasons “why”): stickers, leaflets
- Distribution of an information leaflet ‘Berlin saves water’ to 1 million households in early 1988
- Campaigns in the public and private transport systems, like placing the slogan ‘Berlin saves water’
- Public information about the technical possibilities for water saving (equipment, apparatus)
- Instruction in public institutions (kindergartens and schools)
- Instructions to change consumer behaviour, like:
  - Taking showers instead of full-length baths
  - Running only completely full (not half empty) dishwashers and washing machines
  - Tightening dripping water taps
  - Washing motorcars only in automatic facilities.
- Berlin Water Works information booth at exhibitions, fairs and technical congresses

- Since October 1989 Berlin Water Works, in co-operation with the energy provider BEWAG, established advisory offices in the city area of Berlin, to individually advise users and customers, to display information (posters, brochures, etc) and to present and demonstrate water-saving devices (such as water saving shower nozzles, flushing pans in the toilets)
- Press conference announcing the establishment of these advisory offices and regular insertion of advertisements for the advisory bureaus in the local press to raise awareness
- Public ‘Open Days’ at the Berlin Water Works to spurn interest and provide access to selected facilities.

### Lessons learnt

- The advisory offices should be easily accessible by transport, either public or individual
- An exhibition area should be included in the advisory office
- Greater demand for advice was found in areas with single houses compared to areas with rented homes
- Advisory offices were needed to explain water saving measures at craft, industry and public institutions, such as at kindergartens
- The advisers should be mobile in order to reach customers and users at points of usage
- A comprehensive range of advice is required, from practical to financial information.

### Public relations case study: Mobile Information Buses

Having considered these factors listed above, the Berlin Water Works developed a concept of mobile information buses, that, in the 1990's, moved around supply areas to reach customers directly through spontaneous contact (see Figure 3, below). Special care was taken in outfitting clearly arranged posters and easily accessible leaflet distribution desks to vividly demonstrate the effect of water saving equipment like flow limiters in intake armatures or the flow-through of different shower nozzles. On the entrance side, two awnings were installed on the roof. In fair weather they served as sun protection, in bad weather they served as weather protection (against rain) and they also enabled enlargement of the exhibition area.

Figure 3: Mobile information buses of the Berlin Water Works with the slogan ‘Just think about water’



## **MEASURES FOR THE MINIMIZATION OF LEAKAGE LOSSES**

Whilst such public relations activities were effective in mitigating water loss to a certain extent, a second key aspect of water loss was the problem of water leakages. This comprised a somewhat more technical aspect of water resource management, and is examined below.

### ***Fundamentals of leakage location techniques***

Leakage noises are caused by passing out of water being under pressure and are spread out as body and sound waves. The intensity as well as the frequency of these leakage sounds depends on several influencing factors, which are used for the position finding. A number of techniques and additional strategies to minimise leakage losses are explored in the following sections.

### ***Correlation Measuring Techniques***

Correlation is the computer aided leakage location in pressure pipe systems laid into the ground. The noise caused by a leakage spreads out within the pipe system in both directions with a distinct velocity. It is transformed by converters into electric signals, magnified (radio waves) and transmitted by wireless transmitters to the main correlation unit. The exact position of the leakage may be calculated by means of the difference of the running time of the leakage noises.

### ***Sound-location Techniques***

- Sensitive microphones
- Sound locators (bell-shaped, box or pipe)
- Bell-shaped soil sound locator with filter depression of disturbing noises.

### ***Special Techniques (non acoustic position finding techniques)***

- Measuring the differential pressure (e.g. with a searching 'go-devil')
- Colour test (dyeing of the water)
- Use of test gas
- Infrared thermograph: measuring in the hot water and heating pipes (to be fairly considered for countries with high temperatures and drinking water development from surface waters)
- Mini-pipe-camera: note, not to be used for pipes with incrustations
- Measuring of the moisture
- Use of endoscopes for hardly accessible hollow spaces.

### ***Preventive search for leakage losses***

Whereas previously leakages were identified by spontaneous searches throughout the city, following reunification a more strategic approach was developed, based on a database of the pipe network in order to enable a decisive search of leakage losses, for example in areas with high damage rates. This preventive strategy undertaken by the Berlin Water Works uses a sound level meter and, is designed to be effective enough to be able to be used in a court of law. These sound level meters are installed into hydrants, section gate valves or house connections in order to be able to find the exact positions of the pipes (area exploitation) and then monitor distinctly-selected sections of the pipe system.

### ***Techniques applied***

The sound level meters (loggers), which are equipped with antennas and wireless transmission, were activated in low consumption time periods (from about 1 a.m. to 4 a.m.), in order to perform sound recordings with a low part of external sounds over a distinct time period. The computer-aided evaluations were completed in the vehicle or in the pipe operating office.

The pipes identified were then examined by the emergency service or experts from the pipe network department by means of the correlation measurement technique and thus the exact location of the leakage was identified. For the verification of the results, an additional check was made using earth microphones.

## **Database**

A database was developed, comprising information about the following categories:

- Damage statistics concerning the nature (classification to pipe and material groups, respectively) as well as the cause of the damage, such as natural events, road construction, increasing traffic, increasing truck use due to construction measures, scattering and foreign flows
- Age of the pipes
- Geometrical, geographical and hydraulic data, like diameter, depth position and flow-through capacity
- Type of material
- Pipe conditions
- Amount of damage as relevant
- Hints and statements about leakage losses (especially data from empirical knowledge)

The information also categorised and classified pipe samples according to the following variables:

- Damages caused by the manufacturing
- Damages caused by pipe-laying and mounting
- Technical and biological ageing
- Natural earth movements
- Damages due to the management and to the pipe system.

## **Motives for additional pipe inspections**

Different motives for more pipe inspections were due to hints coming from the public, customer complaints regarding delivery pressure and water quality, high water losses, extraordinary pressure drops, earth movements in pipe areas and changes in the area surface, like gaps and sinking, especially for roads with high traffic.

## **Results of the Measures for Reducing Water Consumption**

Reduction of the leakage losses in the pipe network in the eastern part of the city fell from about 25 percent to a consistent rate of about four to five percent in the whole city area, representing a significant achievement.

## **DEVELOPMENT OF WATER CONSUMPTION IN BERLIN**

Contrary to many predictions, over the ten year period of the campaign undertaken by the Berlin Water Works, the population did not increase and thus nor did drinking water consumption. Rather, there was a slight decrease in water consumption in the western part of the city, achieved by those measures already described (publicity, public relations and installation of water saving equipments and apparatus). Further, due to the implementation of explicit campaigns and tactics designed to foster more conscious use and conservation of water, a dramatic reduction of the drinking water consumption was noted in the eastern part of the city as well. This could be attributed to the following factors:

- Breakdowns in industrial production leading to the closure of many industrial firms
- Higher tariffs for water use causing a dramatic change of attitude of customers changed who adopted a much more economical use of drinking water
- Effective publicity campaigns and public relations activities for water saving
- Availability and installation of water saving apparatus and equipment in households
- Strong efforts of the Berlin Water Works to diminish the leakage losses due to pipe breakages (from about 25 percent to 4 to 5 percent in the East Berlin, thus on a par with West Berlin).

These events in East Berlin were followed from 1993 onwards by a dramatic decrease in water consumption in the western part of the city, caused by a shifting of industry production and slightly increased fees.

Figure 4: Water consumption in million m<sup>3</sup> per year

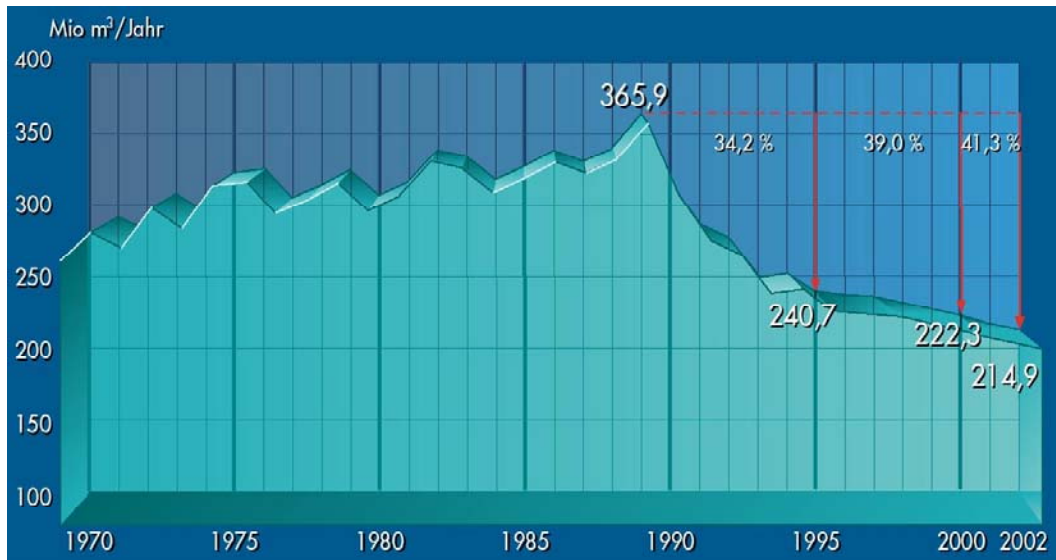

Thus, over the course of about 10 years, the Berlin Water Works succeeded in considerably reducing water losses due to breakages in the pipe system. Household water consumption was halved, from about 250 litres per capita per day to about 125 litres per capita per day (see Figure 2), due to implementation of those different measures described above. Similarly, drinking water consumption was reduced by about 40 percent (see Figure 4 above).

## RECOMMENDATIONS

The reduction of water consumption is a necessary step towards ensuring central drinking water supply in emerging countries or in countries with water scarcity. This is achieved via a multi-stage process. First of all, a general analysis of the water supply situation has to be carried out. Based on the central water supply system and customer attitudes the following important points have to be considered:

- Description of the water supply structure (waterworks, pipe network, storage, water supply capability and capacity, legal form of the water supply companies)
- Climatic data
- Water consumption, including differentiation by consumer groups
- Population trends and demographical analysis
- Forecasts of water consumption development
- Survey of the statutory regulations and technical standards
- Socio-economic framework conditions
- Gross domestic product
- Income relationships
- Tariff system or price system
- Billing methods, use of water meters
- Relation of water price to the cost of living
- Acceptance of recognition of water as a commodity and willingness to pay for this service
- Payment reliability (on time, with/without reminders).

Regarding drinking water distribution, it is necessary to establish an overview and analysis of the various supply areas with respect to the availability and operation of interim storage and qualitative characteristics of the drinking water (in terms of its microbiological properties, re-infestation with germs, contents of disinfectants and temperature at distinctive important points in the distribution system).

Details of the pipe system must also be considered in searching for the best renovation strategy, particularly with respect to pipe properties, such as age; geometric, geographic and hydraulic data (diameter, depth and flow capacity); composite materials; available data on the conditions of the pipe system; type and extent of damage to pipes (if at all); and indications and details of water losses (above all, their empirical values)<sup>1</sup>.

Then, the potential savings in consumers' water consumption should be clearly illustrated, an appropriate public relations campaign should be undertaken, and technical measures should be adapted to specific local conditions (e.g. water saving equipment).

For the water distribution system, actions should include an investigation of the possibilities of carrying out cost-effective damage repair and renovations for pipes; preparation of a decision-making method to choose appropriate construction materials; and localisation of conditions, technologies and costs.

Thus, the optimum strategy for the reduction of water consumption for a specific situation can be identified and put in practise. For the case of Berlin, as previously described in this study, it can be stated that the Berlin Water Works has been able to use its knowledge of and competence in water consumption and related issues, to draw the correct strategic conclusions and transform them into practice.

---

<sup>1</sup> It must be noted that in Germany, similar successes were achieved by Hamburg Water Works, whose actions to install water saving equipment in the mid 1980's led to a reduction of between 10 and 30 percent of water consumption. A similar achievement was made by the City Works of Frankfurt am Main, where in the early 1990's a 'concept for an economical water consumption' led within five years to a decrease in water consumption of about 17 percent.

# MIDDLE EAST DESALINATION RESEARCH CENTRE: A CONTRIBUTION TO DESALINATION RESEARCH AND DEVELOPMENT

Kandi Venkat Reddy and Mousa K. Abu Arabi; Middle East Desalination Research Center, Muscat, Sultanate of Oman; Email: [kreddy@medrc.org.om](mailto:kreddy@medrc.org.om)

## ABSTRACT

The Middle East and North African (MENA) region has the poorest water resources in the world. In this region, desalination has been used to supply the major portion of potable water in some countries or to augment it in others. Although more than fifty percent of the total desalinated water is produced in the MENA region, there are very few water resource research and development activities undertaken in this region. The research facilities are not adequate and they lack sufficient local manpower or proper training to conduct research in desalination.

In recognition of these facts, the Middle East Desalination Research Center (MEDRC) was established in 1996 in the Sultanate of Oman, with the objectives of reducing the cost of desalination, increasing regional research capability, developing productive regional and international cooperation, promoting capacity building in the region, and enhancing information dissemination.

To achieve these objectives the Center has initiated various activities that include: providing partial funds for research in desalination and its related areas with a team involving at least one MENA partner; developing reference materials useful to the desalination community worldwide; contributing to capacity building in the MENA region by organizing short courses in desalination, providing scholarships to students from MENA to obtain degrees in desalination and helping MENA universities to introduce desalination courses in their programs.

This presentation will review the research and development program of the Center with emphasis on the procedures followed for developing research needs in desalination, tendering proposals for research projects, evaluation of proposals received and the results of the sponsored projects.

## INTRODUCTION

The Middle East and North Africa (MENA) region is arid and has extremely poor natural water resources: the per capita availability of renewable water in the region is the lowest in the world. This region has about five percent of the world's population but less than one percent of the world's renewable fresh water. In future, the regional water situation is expected to worsen due to rapid population growth, increasing urbanization and industrial development. Since all of the natural supplies of potable water are already fully exploited in this region, desalination of sea and brackish water has been used to supply the major portion of potable water in some countries or to augment it in others.

Desalination is an energy intensive and relatively expensive process. Presently it is not a viable alternative for water supplies in many countries. Mostly rich countries, particularly oil producing countries, where energy is cheap, are augmenting their water resources with desalinated water. The major challenge to the researchers, process designers, fabricators and plant operators engaged in desalination is to reduce the cost of desalinated water to make desalination a feasible option. Unfortunately, research and development activities are very limited in the MENA region, particularly when considering that more than fifty percent of the total desalinated water is produced in this region.



Research facilities are inadequate and local human resources not sufficiently trained to conduct research in desalination. Additionally, the means of disseminating information and knowledge related to desalination is also poor.

In recognition of these facts and as a consequence of the deliberations of Middle East experts within the Working Group on Water Resources, the Middle East Desalination Research Center (MEDRC) was established on December 22, 1996 in the Sultanate of Oman, with the following objectives:

- to reduce the cost of desalination;
- to increase regional research capability;
- to develop productive regional and international cooperation;
- to build capacity in the region at Universities and in desalination practice;
- to develop sustainable desalination technologies that are affordable, energy efficient and environmentally conscious;
- to develop reference materials about desalination, including reviews of latest industry developments, design tools and databanks;
- to enhance desalination information dissemination.

The Center offers the region and the worldwide desalination community a number of benefits. These include:

- provision of new funding for research, drawn from within and outside the region;
- acting as a vehicle for support and interest in regional water issues at a very high political level around the world;
- improving access to desalination technical expertise in the region and worldwide;
- a mandate to contribute to the reduction of desalting costs in order to improve the quality of life for people in the region, and by extrapolation, the rest of the world;
- the ability to assist in solving problems of mutual interest at any site in the region;
- the opportunity for existing research programs to cost-share research projects, thereby leveraging their financial and technical resources, as well as fostering the improved exchange of information between researchers;
- a forum to optimize the utilization and coordination of existing research facilities;
- the opportunity for regional experts to participate in setting research objectives for the region;
- access to regional source of international information in desalination;
- training and capacity building in desalination in the region by organizing short courses and providing scholarships to students from the region to study abroad.

## **RESEARCH AND DEVELOPMENT PROGRAM**

The research program is the foundation of the Center's activities. The mission of this program is to conduct, facilitate, promote, coordinate and support basic and applied research in desalination and supporting fields, in order to reduce the cost of desalination. The Center planned the following activities for accomplishing its research program mission objectives:

- sponsored research
- in-house research
- scholarship program
- capacity building
- technical support and assistance.

These activities are described in more detail below.

## **Sponsored Research**

The Center's major activity has been to provide financial support to research projects focused on desalination and its related fields, particularly those that aim to reduce the cost of desalination. This program has been conducted since the inception of the Center.

### **Prioritization of research areas**

The Research Advisory Council (RAC) advises and guides the Center in formulating a research and development program and capacity building activities. It is composed of about twenty international experts in desalination, including academic, public- and private-sector experts who are geographically representative of the region. The RAC membership is voluntary, with one third of the members rotating to RAC alumni status each year.

The Council convenes once a year in a workshop meeting to prioritize the research areas and suggest research projects for the ten topic areas mentioned below, specifying each project, its objectives, tasks and the budget:

- thermal desalination
- membrane desalination
- alternative desalination technologies
- hybrid systems
- energy issues, renewable energy integration
- operation and maintenance
- intake and outfalls
- environmental issues
- assessment studies
- certification programs.

The research director/ project managers select the projects to be included in the next request for proposals (RFP) from the list recommended by the RAC. The annual RAC meetings are also utilized to discuss research findings of completed projects.

Another approach to develop proper project themes and contents for complex research topics for the RFP and to identify the organizations to undertake such projects and acquiring reference materials on a specific subject could be achieved by organizing conferences/ workshops on that particular topic. Two types of workshops identified in our action plan are outlined in the following sections.

#### ***Type A: Multi-Institutional (MI) Projects***

Some research and development themes are too complex and multi-disciplinary to be accomplished in a single project and by a single institution. Such major undertakings are carried out most effectively via a coordinated approach, with a consortium of institutions comprising different, complementing expertise, saving time and costs.

The purpose of the first type of workshop is therefore to lay the foundations for such a project, with the following agenda and projected outcomes:

- a brief review of the state of knowledge
- assessment of the tasks and goals of the project
- definition of the work packages
- identification of potential experts and institutions for the work packages
- estimation of the budget and schedule required
- identification of the coordination team
- identification of organizations to approach for funding
- preparation of documents for a fund raising campaign

The final products are a document that serves as a reference for the various elements of such a consorted MI project, and documents required for a fund raising campaign.

MEDRC considered organizing conferences/workshops on desalination costing and the environmental issues and sustainability aspects of desalination.

An international conference on desalination costing was held from the 6<sup>th</sup> to the 8<sup>th</sup> of December 2004, in Cyprus, with the intention of laying the foundation for the development of a standard costing procedure. The conference delegates produced and agreed on the tasks required to reach a generally accepted methodology. The written product of this conference was a compilation of the treatises, notes from the conference discussions and a definition or outline of the further work to be accomplished. With this material in hand, MEDRC is planning to approach various organizations to raise the funds to finance the surveys and investigation projects required for completion. The ideal outcome would be the creation of a globally-accepted standard costing procedure.

Over the past two years MEDRC has been approached by a variety of institutions or individuals with questions on issues related to environmental and sustainability aspects of desalination, with research and development proposals on components of these issues, or with the recommendation that these are issues to which MEDRC should contribute, progress and for which solutions should be developed. Hence the MEDRC is planning to organize a workshop in 2005-06 in which the issues and the problems are assessed and the required work packages to tackle them are defined. The topic of the environmental impact of desalination and the discussion of sustainability of desalination technology as a major resource of water in arid areas is increasingly often brought into the arena of water policy makers and the technical desalination community. So far, this issue is being addressed by entities involved in environmental studies and policies. The desalination community is challenged to participate in this process through a systematic approach to the facts and issues.

### ***Type B: Assessment of State of the Art / Industry Developments***

Another type of workshop serves to review and compile the latest developments in particular fields, to conjointly formulate solutions to specific problems, and to specify future research and development requirements. The objective could also be the production of a handbook on that topic area. The MEDRC is planning this type of workshop for the time when a coherent group of projects has been completed.

### **Request for research proposals**

The Center announces yearly calls for specified research projects prioritized by the Research Advisory Council and at the same times considers meritorious proposals received for unsolicited projects. Project proposals can be submitted any time during the year and proposals are processed as and when they are received.

Applications must demonstrate technical merit and a reasonable budget, with funding requirements also stipulating at least 50 percent cost sharing by a research partner from the Middle East and North Africa Region. The project must also have a component that can serve as reference material.

The cost share component can consist of cash and/or in-kind contributions from the applicant's institution, from donors or from other research and development funding organizations. Although in-kind contributions can come from a variety of sources, the primary objective is to encourage cost sharing when cash is not readily available. In-kind contributions can include labor, materials, leasing of facilities or equipment from other organizations, or other similar services contributed at their

realistic fair market value. In special cases, identified as such, the Center may consider granting more than 50 percent of the project costs.

The Center places a very high priority on the formation of research partnerships, which include at least one organization or institution from the Middle East and North Africa (MENA) region as a member of the research team. A long-term objective of the Center is to stimulate capacity building for more research into desalination within the region. Accordingly, the Center seeks to supplement and complement the work of the existing organizations and institutions within the region. The Center also helps to obtain appropriate research partners. The requirement of forming research partnerships can be exempted for projects dealing with data banks, reference materials, or capacity building.

As a contribution to the Center's commitment to technology transfer, capacity building and knowledge dissemination, every Center-funded project shall include a component that will serve as an advanced source of reference on the topic under investigation. This can be a comprehensive literature survey, review and evaluation which can be of value to someone already working in or initiating work in the subject area, a comprehensive presentation of design calculation tools, an assessment of solutions to a certain problem, or a systematic collection of specific data relevant to the topic under investigation. This contribution is expected to comprise a separate chapter of the final report and should be clearly identified in the proposal. Proposals are also judged by the value of this contribution.

The Center recognizes that the preparation of a full proposal requires a considerable commitment of resources both on behalf of the applicant and the Center. In order to minimize time and expenditures resulting from an unsuccessful application and to improve the quality of proposals, the Center encourages the applicant to first submit a pre-proposal for review and comment by the Center prior to submitting a full formal proposal. Further, the Center developed a document - Guidelines for the Preparation of Research Proposals - to provide details of the requirements and procedures for the preparation of research proposals for solicited and unsolicited projects.

In the 2004 Request For Proposals (RFP), around hundred research projects were included, with different levels of priority, denoted as A, B, C and unsolicited, as described below:

**Type A:** Higher priority projects, considered to fit particularly well into the current research program or to fill a gap in a series of related projects. This type of project comprises about one third of the total number of projects. Project outlines are provided for them.

**Type B:** Lower priority projects. the Center will accept proposals (preferably as a pre-proposal first) for projects that are exceptionally attractive in terms of importance and quality, or by value of a cooperation scheme, or for the creation of reference materials, or utilizing a special opportunity for a project.

**Type C:** Topics of currently on-going and completed projects. The Center will consider proposals if they suitably supplement these projects or approach the topic with a different, attractive objective. Generally, same project team is not encouraged to submit proposals and encouraged to submit pre-proposals first.

### **Self-specified, unsolicited proposals**

The Center recognizes that its method of soliciting specific proposal topics, based on a prioritization of projects and the research budget, may not always be inclusive enough to cover all critical research topic areas or new approaches. Therefore, the Center also encourages the submission of research proposals for projects other than those specified as Type A, B and C. The proposed project must relate to desalination technology or its fundamentals and show merit and value in the context of the research program. Pre-proposals should also be submitted for this type of project. The requirements, guidelines and evaluation procedures for the unsolicited proposals are the same as for solicited proposals.

## Proposal process overview

The Center to date has issued twelve requests for research proposals (RFP's). The number of proposals received for each RFP is listed in Table 1. The response was good for the first RFP, but gradually started decreasing in the subsequent RFPs. This led the Center to increase the number of projects tendered in sixth RFP in 2000 and made the projects wider in scope. This has improved the response to subsequent RFPs.

Table 1: Response to Request for Proposals

	Last Date for Submission of Proposals	Number of Projects Tendered	Response (Project) Proposals	No of Projects Awarded	No of Projects Under Evaluation
1	January 1998	10 P	(10 P) 28	11	---
2	September 1998	8 P	(5 P) 18	4	---
3	January 1999	7 P	(2 P) 6	2	---
4	August 1999	7 P	(4 P) 8	5	---
5	February 2000	5 P	(1 P) 1	---	---
6	September 2000	Categories A: 38, B: 36, C: 10	22 Pre-proposals; 8 Proposals	7	---
6	January 2001	Categories A: 38, B: 36, C: 10	13 Pre-proposals 2 Proposals	1	---
7	September 2001	Categories A: 44, B: 36, C: 14	3 Pre-proposals	---	---
7	January 2002	Categories A: 44, B: 36, C: 14	7 Pre-proposals; 2 Proposals	2	---
2002	January 2003	Categories A: 38, B: 37, C: 14	10 Pre-proposals; 8 Proposals	3	---
2003	December 2003	Open	36 Pre-proposals/ proposals	7	3
2004	December 2004	Categories A, B, C:	15 Pre-proposals/ proposals	-	8

Even though the response to RFP 2002 was adequate, the Center made the RFP 2003 more general to attract more proposals. This RFP was simplified and made more flexible than earlier calls for proposals. It was not limited to specific project titles and contents, thus providing for more options in submitting a research proposal for funding. This open approach also seeks to attract and encourage more relevant and good quality proposals.

Although more proposals were indeed attracted for RFP 2003, as most of them were not relevant to desalination, in a July 2003 meeting the Research Advisory Council (RAC) decided that the Center should revert back to defining and describing the projects in the 2004 call for proposals. The Center staff and Project Advisory Committee members spent a considerable amount of time evaluating the unrelated project proposals. RAC also felt that the open RFP would not allow the Center to specify more important topics that need research. Therefore the Center reverted back to defining and describing the projects in RFP 2004. The Center received 19 pre-proposals/proposals as of July 31 for

RFP 2004. Out of these, 11 were rejected; four were internally reviewed and requested the project investigator to submit revised proposals, while four more were processed with the help of Project Advisory Committee members.

**Projects awarding and progress monitoring**

For each project pre-proposal/proposal received, a Project Advisory Committee (PAC) is appointed, comprising experts in the subject area of the project. This committee, the research director and the project managers evaluate the proposals received and make decisions for funding the appropriate projects. With the help of project manager, a Contract Manager finalizes the project schedules and contract. After the project starts, the project manager, with the assistance of PAC members, monitors the project progress and the quality of the research work. Figure 1 (below) summarizes schematically how the research program is managed by the Center.

**Research results**

The Center has awarded contracts for 44 projects and one project is in the process of having its contract finalized, as at 31 July 2004. The status of these sponsored projects, including the total budget and the Center contribution for each project, are presented in Appendix 1. Nineteen out of 44 projects are completed, for which final reports have been received to date. Fifteen of these final reports are edited. All the final reports of completed projects are placed on the MEDC’s web page as downloadable files and circulated to the desalination community on a CD along with our 2003 annual report. The total value of all the 45 projects is US\$6,769,742, with the Centre contributing US\$3,173,418.

Figure 1: Schematic diagram of research program management

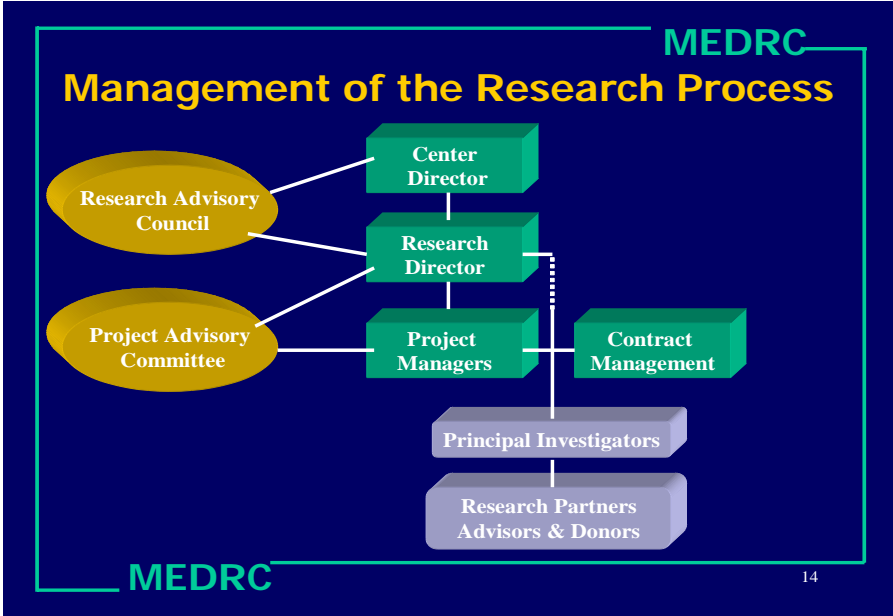

The outcome of the sponsored research is excellent. Many articles have been published and/or presented in reputed journals/conferences on desalination based on the work carried out in the sponsored research projects: 43 papers in journals, 42 papers presented at international conferences, and 22 papers presented at national conferences/seminars/workshops. The technical staff of the Center also contributed 25 papers/presentations.

The research results of some of the projects have found applications in the desalination industry and some project results have great potential for commercial application. The following are the details of the completed projects highlighting the project goals, achievements and applications.

*'Novel Material Selection To Improve Corrosion Resistance'* is an applied research project and in this project a comprehensive survey of material performance in multi-stage flash (MSF) and multi-effect distillation (MED) plants over the past 25 years has been carried out. Based on this survey, a standard materials selection guide was developed and also identified new materials with potential use in MSF and MED plants. The material selection guide developed is useful to MSF plant designers, consultants and plant operators and is already being used by many material suppliers to help identify application of their products in MSF and MED plants.

The *'Development Of New Technologies For The Reduction Of Fouling And Improvement Of Performance In Seawater Reverse Osmosis (RO)'* project evaluated the potential of capillary pre-treatment technology (ultrafiltration, or UF) in the RO seawater desalting process to produce high quality feed water, eliminate membrane fouling, improve operating parameters and reduce desalted water cost by conducting long-term field tests of UF and RO. The technical and economical parameters of the UF were compared with conventional pre-treatment process. This was an applied research project, the results of which were utilized by Mekorot in preparation of specifications for a large commercial RO desalination system to be built in Ashdod, Israel.

The *'Identification Of Critical Flux And Cross Flow Conditions For Control Of Bacterial And Organic Fouling Of Seawater Reverse Osmosis Membranes'* project has basic and applied research components. In this project critical flux values were determined in the laboratory-scale filtration test equipment using a 'direct observation through membrane' (DOTM) technique for Oman seawaters. Then a pilot-scale reverse osmosis facility was set up in Muscat to evaluate critical flux values for various operating parameters. Subsequently, an attempt was made to develop a computer program using the data collected in the DOTM experiments and reverse osmosis pilot plant in order to calculate the critical flux values for different feed waters. This project helped with capacity building in Oman and Palestine. If a comprehensive computer program for evaluation of critical flux was developed in this project as proposed, it would have been a very useful product for the evaluation of critical flux in all the reverse osmosis plants in operation in the Gulf countries.

In the *'Study Of The Formation And Inhibition Of Silica Scale In Reverse Osmosis Desalting'* project, correlations for the silica solubility and scale formation kinetics were developed and established safe limits at which there the danger of silica precipitation on the membrane was eliminated. Techniques for methodical evaluation of silica scale propensity in reverse osmosis systems and procedures for characterization of anti-scalants were developed. The optimal quantities of chemicals required for reducing silica concentrations to acceptable limits in the conventional pretreatment process for a commercial-scale reverse osmosis plant for different silica concentration feeds was also estimated.

Disposal of brine from inland desalination plants is significant both economically and environmentally. Evaporation ponds are increasingly used for this application. In the *'Investigation Of The Use Of Evaporation Ponds For Brine Disposal In Inland Desalination Plants'* project, a literature review on concentrate disposal technology using evaporation ponds was performed. It assessed the current status of the concentrate disposal technology in inland plants by collecting the data from 23 desalination plants in Oman, Jordan, and the United Arab Emirates and described some innovative research ideas on this issue. A literature review revealed that evaporation ponds are a viable method in countries with dry and warm weather and low land cost. Plant visits showed that in many of these plants there is pond leakage and there is no monitoring of the disposal system. This applied research project and results will be helpful in developing efficient brine disposal technologies with enhanced evaporation.

The Center has also sponsored two applied research projects on hybrid desalination systems. The first one is about effective integration of membrane/thermal desalination and power technology to reduce

the cost of desalination and electrical power production. In this project, integration of desalination systems with power technology was considered. Various hybrid schemes for coupling power and desalination plants were proposed. These schemes offer flexibility in water and power production in order to meet seasonal demands, increased water to power ratio, reduced cost of desalination, increased reverse osmosis membrane life and reduced cost of seawater intake system. In the second project, integration of different desalination systems into a hybrid system combining the best features of each process was performed. First, a literature search was conducted to identify various hybrid concepts. Economic analysis was then performed for the selected systems in order to identify potential means of saving costs. Six hybrid desalination concepts were identified, needing further development or demonstration in order to be properly assessed. However, *a priori*, these hybrid concepts could benefit most MENA countries, as one of the main motives for these projects was to develop solutions for the imbalance of electrical power demand in summer and winter. Such new concepts are therefore also of consequence for Oman.

A new technology has been developed and up-scaled in the project entitled '*A Novel Method To Permanently Improve The Salt Rejection Of Reverse Osmosis Desalination Modules To Significantly Lower The Cost Of Desalination*', in order to repair imperfections found in reverse osmosis elements. It was applied to severely damaged elements containing large imperfections and to new commercial elements to improve their salt rejection. The salt rejection for the commercial elements was improved to 99.8 percent, and the damaged elements were successfully restored to their original conditions, with a slight decrease in flux. The technology developed has great potential for industry application.

In the project on '*Beach Well Intakes For Small Seawater Reverse Osmosis Plants*', a comprehensive state of the art review of utilization of beach wells and similar non-surface seawater intakes for seawater reverse osmosis (SWRO) systems was performed. The criteria for the choice and design of these types of seawater intakes were also developed. A data processing framework has been developed including spreadsheets for cost estimates based on site properties. The results of the project provide an improved design solution for seawater intakes and reduce significantly the intake cost as well as pre-treatment cost.

The project on '*Critical Assessment Of Fouling Indices*' is an applied research project in which a comprehensive literature survey and critical evaluation of fouling and scaling problems in membrane desalination plants was carried out. This survey included pretreatment methods to prevent fouling (with emphasis on advanced processes) and water quality parameters for predicting the severity of such problems and the efficiency of pretreatment. Laboratory and pilot reverse osmosis fouling tests with model waters containing iron oxide and humic acids were carried out to contribute to the development of improved standards for specifying fouling indices. The main results of the projects were a well-documented account of merits and drawbacks of available fouling/scaling indices; recommendations about improvement of available tools for predicting the fouling/scaling propensity of reverse osmosis membrane feed waters; and recommendations about the need to promise new testing procedures and conditions to lead to more reliable, yet time-saving and cost-effective predictions.

The Center has also sponsored fourteen projects related to renewable energy (as at 2004). Amongst these, nine projects, described in detail in the sections below, have been completed (as at 2004).

The primary focus of '*VARI-RO™ Solar Powered Desalting Study*' was a theoretical study to determine the technical viability and potential to improve solar powered reverse osmosis processes using new approaches: solar trough collectors, solar dish collectors, hydraulic drive pumping and energy recovery and a direct drive engine. The results of the study indicated that it is feasible to increase the quantity of fresh water production per unit of solar energy collector surface area when combined with direct drive engine and seawater reverse osmosis (SWRO) desalination. Up to 300 times the fresh water can be produced as compared with simple solar stills, which produce only four litres per day per square meter of solar surface area. Based on this study, the principal investigator is planning to build a pilot plant to confirm the theoretical predictions.



The '*Seawater Greenhouse Development for Oman: Thermodynamic Modelling and Economic Analysis*' project concentrated on establishing the configuration and dimensions for a greenhouse to produce various crops and potable water with solar energy and seawater as resources and evaluated the optimum operating conditions for Oman climatic conditions using modelling and simulation techniques. This study has led to the construction of a pilot seawater greenhouse at Sultan Qaboos University Desalination Research Center in Al Hail, which is in the commissioning stage.

Coupling the renewable energy systems with desalination units is a realistic solution for supplying water and electricity to water-scarce areas that lack grid-based electricity. Desalination plants powered by renewable energies need to be well-designed since such systems require high specific investment costs. A state of the art review was carried out in the project entitled: '*Matching Renewable Energy with Small Unit Desalination Plants: literature review and analysis of the state of the art of renewable energy and desalination systems*'. Typical combinations of renewable energies and desalination plants were shown. Important factors, which have to be considered in the selection process, were discussed.

In the project '*Matching Renewable Energy With Small Unit Desalination Plants: development of a PC-based decision support system*', an easy-to-use decision support system (DSS) was developed based on a literature review carried out in the pilot project. The software developed allows the user to evaluate different combinations of various small-scale desalination plants powered with solar or wind power for different local conditions and fresh water demand. This software also calculates the specific water cost for each combination in order to select the best combination. It is a useful tool in selecting appropriate combinations of renewable energy desalination systems. This software is made available upon request, free of charge.

Hybrid power supply systems (Wind/PV/diesel) in conjunction with reverse osmosis units, for seawater as well as for brackish water desalination, may be a practical option to provide fresh water at a reasonable cost for remote locations. In a project on '*Development Of A Logistic Model For The Design Of Autonomous Desalination System With Renewable Energy Sources*', a logistic model for the design of autonomous hybrid power supply systems to power reverse osmosis units for the desalination of brackish and seawater was developed. It is a user-friendly program operating in a Windows environment. The power supply system comprises wind generators, photovoltaics, and diesel generators. The software includes an economic analysis model to estimate the unit water cost based on the life-cycle cost analysis approach. This package helps engineers in the process and component design of the hybrid power supply system as well as the reverse osmosis unit for a specified capacity based on the climatic and meteorological information of a specified location. It has provisions for achieving the 'best design' for the least cost option for water supply, through several alternative flow sheets and component configurations through simulation. This software is made available free of cost upon request.

In the project '*A Comprehensive Study Of Solar Desalination With Humidification Dehumidification Cycle*', a survey and summary of work previously carried out on solar desalination utilizing humidification-dehumidification principles, a comprehensive review of the reported calculation methods on these processes with strong emphasis on the heat and mass balance equations, a review of economic evaluation and cost analysis of the process and a comparison of the economics of all the different desalination techniques were performed. The results of this project could serve as reference material for future developments in solar desalination based on the humidification-dehumidification principle. The project provided a detailed analysis of the various parameters of the unit and the effect of these components on the performance of the unit. A copy of this report has been requested by many organizations.

The need of small desalination plants in arid sunbelt countries for applications such as for small villages, industrial units or remote tourist resorts, is growing. In this project '*Hybrid fossil/solar heated multi-effect-still*', which can utilize solar/fossil heat sources, was developed. The multi-effect-still (MES) unit with four effects based on the principles of humidification and de-humidification of

air was successfully designed, constructed and tested. Infrastructure for future field-tests of the developed system in Morocco was built. Technical and economic potential for manufacturing of the technology in Morocco was studied. An MS-EXCEL workbook for technical and economic comparison of different small size desalination technologies (typically for 10 m<sup>3</sup>/day), including thermal and membrane system, was developed. This workbook is very useful for pre-feasibility studies and it is used by some research institutes in Germany.

In the applied research project '*Small Thermal Water Desalination Systems Using Solar Energy or Waste Heat*', an innovative small-scale seawater desalination system (based on the humidification/dehumidification principle) has been operated and monitored on the test site of the Sultan Qaboos University in Oman for one year in order to evaluate its performance in local conditions. It is driven by solar thermal energy and is suitable for remote areas without power supply. The main finding of the project was an improved set of technical parameters describing the components of the system. This experience facilitated the design of three different capacities - 1000, 5000 and 10,000 litres per day units - for commercial production. These commercial units were to be delivered to Saudi Arabia and Egypt by the end of 2004.

The '*Photovoltaic (Pv) Powered Desalination: Matching Technology with Market Requirements In A Market Survey*' project involved technical and economic analysis and comparative study of reverse osmosis and electro-dialysis processes powered with photovoltaic energy. The project also developed guidelines for selection and design of plants involving these processes, identified feasible applications and, hence, accelerated opening of priority markets integrating suitable technology options and stimulated technology development and creation of tools for design and manufacturing of promising technologies. The study identified some niche applications for PV- powered desalination, but the project partners concluded that the limited volume represented by these niches does not justify a dedicated product development or marketing effort.

### **In-house research**

This activity lies within the Center's main objective, namely to conduct, facilitate, promote, coordinate and support basic and applied research in desalination and related fields to reduce the cost of desalination. The Center has been always eager to initiate in-house research and create research facilities in Oman. Local research activity would demonstrate real commitment to technical development in, and technology transfer to, the MENA region, plus encourage other countries from outside the region to participate and contribute to these activities. The Center also envisages the following additional benefits through in-house research at MEDRC:

- to facilitate the establishment of the direct cooperation of scientists, researchers and academics from the MENA countries and elsewhere using MEDRC's research facilities, which help build capacity in the MENA region
- to help transfer the latest technologies and developments in desalination and related fields to the MENA countries
- to act as an information center for the desalination community worldwide and for the MENA region in particular
- to assist Masters and *Ph.D* students from the MENA countries to conduct their research work
- to help conduct training programs for the desalination community mainly from the MENA region
- to test and evaluate new technologies in local conditions.

The Executive Council, in its meeting in December 1998, realized the necessity for in-house research and suggested constructing a building to become MEDRC headquarters and to include laboratories, workshops and a library etc, to carry out applied in-house research and to support capacity building, training and technical assistance. The proposed building would take place in a plot of land given by

Sultan Qaboos University (SQU) in their proposed science park, adjacent to their existing desalination research facility at Al Hail on the coast southeast of Seeb near Muscat, in exchange for the land donated by the Government of Sultanate of Oman at Al Hail. This exchange of land is considered to facilitate the mutual sharing of research and development facilities between the SQU desalination facility and the Center.

The MEDRC prepared plan outlines and a cost estimation for a 2000 m<sup>2</sup> facility and planned to implement it in modular and staged phases. This facility of 2000 m<sup>2</sup> will provide space for a research and administrative staff of 30, meeting rooms, library, laboratories and workshops, a seawater intake and outfalls, training areas and a small lecture hall, along with usual utility areas, storage, caretaker accommodation and external areas for equipment testing and pilot demonstrations. Phased development would spread the investment, and allow the form and facilities of the research center to change according to circumstances and with the benefit of experience.

### **Scholarship Program**

The Center recently launched a scholarship program for Master of Science (MSc) and Ph.D. students from the Middle East and North Africa region to provide an opportunity to study at foreign universities while participating in a MEDRC research project. It is expected that students will gain skills that will make a long-term contribution to the further development of desalination in their respective countries. The program also aims to increase cross-cultural understanding by stimulating international exchange.

The general criteria for MEDRC scholarship award is as follows:

- applicants must be nationals from a MENA country, and hold the equivalent of a BSc or MSc.
- applicants must be accepted for further studies by a reputed university.
- applicants must demonstrate a desire to contribute to their country's advancement in the field of desalination.
- the PhD or MS thesis should be directly related to a desalination topic. The proposed research is processed as any regular research and development proposals submitted to the Center.

The Center has already sponsored three students for the PhD program and two students for the MSc. The Center is also keen to develop a program that will permit MENA region universities to provide opportunities to obtain a Ph.D. degree. The model will be similar to the government funded 'Channel System' scholarship in Egypt, whereby qualified candidates are supervised by a professor at the home university and by a colleague abroad. The candidate conducts part of this research at the university abroad, but much of it also at the home university. The Center will use a portion of its research and training budget to launch this program. It is hoped, however, that the program will motivate regional governments to contribute by financing scholarships, and it is expected that the program lend itself to approach relevant international organizations for funding.

### **Capacity Building**

Considerable research and development efforts are needed to reduce the cost of desalination. Even though the costs are high, a large number of new plants are going to be set up in the MENA region to meet the growing needs due to increase in population and per capita consumption of water. These requirements call for development of human resources and expertise in the MENA region.

## **Courses and Degrees in Desalination**

One approach to reduce the cost of desalination is to develop new technologies by conducting basic and applied research. The other approach is to improve on existing processes. The MENA region universities/ research centers have no resources, facilities or manpower to develop new technologies. Much of the research work undertaken in these universities is assessment studies, process simulation for performance evaluation of existing plants, small desalination systems and renewable energy applications. Recognizing this, the Center is helping to initiate Ph.D. programs and to introduce postgraduate courses in the MENA universities and has developed scholarship programs to provide the opportunity for MENA citizens to study abroad. As a first step in this endeavor, MEDRC has sent an awareness-raising letter to MENA universities emphasizing the importance of desalination in the region to augment the water needs and the required workforce to meet this challenge. The Center is encouraging MENA universities to establish courses and degrees in desalination. The Center is willing to provide assistance to all interested universities.

## **Training in Desalination Practice**

There are many projects underway for building new desalination plants in the MENA region. The value of such projects is about US\$ 2 billion per year; most of it distributed in the Gulf countries. Unfortunately the MENA region lacks the required human resources to fill the needs and facilities to train such personnel. Recognizing these facts, as an initial step to meet the demand MEDRC initiated a program last year to conduct short courses in desalination for MENA citizens. MEDRC has so far conducted the following short courses:

- Thermal Desalination Processes, at Sultan Qaboos University, Muscat, Oman, Sept. 13-17, 2003
- Membrane Technology in Drinking and Industrial Water Treatment, Amman, Jordan, October 12-16, 2003
- Membrane Technology in Drinking and Industrial Water Treatment, at Sultan Qaboos University, Muscat, Oman Jan. 17-21, 2004
- Membrane Techniques for Brackish and Seawater Desalination: Principles - State of the Art, Tunis, Tunisia, February 23-27, 2004
- Membrane Techniques for Brackish and Seawater Desalination: Principles - State of the Centre, at CNRST, Rabat, Morocco, June 14-18, 2004
- Thermal Desalination Processes: Fundamentals and Practice, Dubai Aluminum Co., Dubai, June 26-30, 2004.

To tackle the problem at a grass root level, the Center was keen to determine the actual demand for human resources in the MENA region and, based on that demand, to plan the establishment of a training center. The Center Director approached the German Ministry for International Cooperation (BMZ) for funding a survey of the demand and for the program development of the Center for training in desalination practice (CTDP). The BMZ put the project in the hands of the GTZ (Gesellschaft für Technische Zusammenarbeit), which has elected to first carry out a pre-feasibility study and then a feasibility study, the former of which has been concluded. This study is a general survey in the MENA region to determine the need, the feasibility and the sustainability of such a center. The Center is also planning to develop more tangible activities in this area.

## **Technical Support and Assistance**

The Center extends technical assistance to the countries in the MENA region. The Center has coordinated a survey project for establishing a center for training in desalination practice (CTDP) in Aqaba, Jordan. The survey, its undertaking and results, sought to achieve the following:

- Forecast the anticipated demand for various categories and grades of personnel for whom courses could be organized at the CTDP for establishing the scenarios with regard to type of courses and frequency;
- Assess the suitability of the existing facilities and suggest required additional facilities for CTDP;
- Develop a detailed training schedule covering classroom work and hands-on-work experience at the desalination plants;
- Review water related certification schemes and recommend proper certification, which will qualify the holder an appropriate position in any of the MENA countries;
- Develop schedule for training materials necessary for the implementation of the course program;
- Prepare business plan for the first three years of the operation of the CTDP;
- Identify the organizations likely to be interested in donating funds to the CTDP for conducting the training courses initially and prepare a document to approach these organizations for funding.

MEDRC also helps the desalination industry, researchers, consultants and others in solving their technical problems through MEDRC technical staff, or directs them to an expert in the field.

The Center assisted the USAID agency in Jordan to develop the program for the seminar entitled 'Desalination Options for Jordan' (August 18-19, 2003). The Center proposed the agenda, suggested speakers and participants, and contributed to presentations. The Center also provided its website to host information about the outcomes of the seminar.

The Center Director is on the Advisory Panel for the World Bank Study entitled 'Seawater and Brackish Water Desalination in the Middle East, North Africa and Central Asia', which was to be concluded in the early part of 2004. The study is nearly completed with results pointing to two major issues in desalination which are in line with the two MEDRC specialty workshops dealing with desalination costing and environmental issues. Capacity building and integrated water management to incorporate desalination will be the key focus of the World Bank in the Middle East countries that are of priority for the bank.

The United Nations' Food and Agricultural Organisation (FAO) called for an expert panel to discuss desalination and irrigation. The Center Director was a member of the panel which had heavy Spanish presence as they are the biggest users of desalination in agriculture. The development of general operation and maintenance guidelines for brackish and seawater desalination by reverse osmosis, as reported, is under preparation.

## Appendix 1

### List of Sponsored Research Projects

Ser. No.	Project Title	Total Project Value (US\$)	MEDRC Contribution (US\$)
1	Novel Material Selection to Improve Corrosion Resistance	91,050	40,000
2	Development of New Technologies for the Reduction of Fouling and Improvement of Performance in seawater RO	467,745	233,180
3	Identification of Critical Flux and Cross-flow Conditions for Control of Bacterial and Organic Fouling of Seawater Reverse Osmosis Membranes	621,724	217,768
4	Study of the Formation and Inhibition of Silica Scales in RO Desalting	250,000	100,000
5	VARI-RO™ Solar Powered Desalting Study	40,000	20,000
6	Seawater Greenhouse Development for Oman: Thermodynamic Modeling and Economic Analysis	39,473	19,597
7	Investigation On The Use Of Evaporation Ponds For Brine Disposal In Inland Desalination Plants	85,400	45,200
8	Hybrid Desalination Systems: Effective Integration of Membrane/Thermal Desalination and Power Technology	242,210	70,000
9	Hybrid Desalination Systems	139,674	69,837
10	Matching Renewable Energy with Small Unit Desalination Plants Part I: Literature Review and Analysis of the state of the art of Renewable Energy and Desalination Systems	48,909	22,500
11	A Novel Method to Permanently Improve the Rejection of Reverse Osmosis Desalination Modules to Significantly Lower the Cost of Desalination	276,603	128,878
12	Beach Well Intakes for Small Seawater Reverse Osmosis Plants	81,132	39,960
13	Hybrid Fossil/Solar Heated Multi-Effect-Still	283,650	58,000
14	Investigation of Small Home-Use RO Units	74,024	34,928
15	Small Thermal Water Desalination Systems Using Solar Energy or Waste Heat	196,021	84,321
16	Small Solar MED Desalination Plant	210,812	100,000
17	PV Powered Desalination: Matching Technology Options with Market Requirements	66,641	32,500
18	Data Bank of Seawater Compositions	100,000	90,000

Ser. No.	Project Title	Total Project Value (US\$)	MEDRC Contribution (US\$)
19	Development of Logistic Model for the Design of Autonomous Desalination System with Renewable Energy Sources	85,396	41,000
20	Matching Renewable Energy with Small Unit Desalination Plants Part II: Development of a PC-based Decision Support System	53,286	22,516
21	Critical Assessment of Fouling Indices	100,000	50,000
22	Study of the Interactive Effects of Inorganic and Biological Fouling in RO Desalination Units- Phase A	115,000	56,000
23	The Release of CO <sub>2</sub> in Multiple-Effect Distillers	127,836	63,900
24	Assessment of the Freezing-Melting Process for Desalination of Seawater	33,870	15,185
25	A Comprehensive Study of Solar Desalination with Humidification-Dehumidification Cycle	41,566	26,869
26	Spirulina Culture Using Reject Brine Water from Desalination Plants	64,158	33,098
27	Computational Fluid Dynamics (CFD) Studies for Performance Enhancement of Spiral Modules by Modifying Fluid Flow Behaviour	131,934	65,967
28	Design and Development of a Small Packaged Reverse Osmosis System Driven by Hybrid Power Supply System	211,390	105,695
29	Automation and Operation Optimization to Reduce Water Costs	99,800	49,900
30	A Study of the State of Art, Commercial Potential, and Prospects for Advancement of Desalination by Membrane Distillation	64,000	32,000
31	Enhanced Evaporation for Treatment of Desalination Brines	302,415	110,115
32	Assessment of the Composition of Desalination Plant Disposal Brines	126,370	63,100
33	Development of a novel approach to the prediction of nanofiltration membranes performance using advanced Atomic Force Microscopy (AFM)	292,130	133,700
34	Study of the Interactive Effect of Inorganic and Biological Fouling in RO Desalination Units – Phase B	83,000	37,000
35	Basic Experimental studies of the CO <sub>2</sub> release and the Carbonate System in Seawater Distillation	223,974	100,481
36	Review of colloidal fouling in spiral wound modules	33,124	30,124
37	Combined molecular absorption & coagulation for improving pre-treatment process in desalination	226,120	144,120

Ser. No.	Project Title	Total Project Value (US\$)	MEDRC Contribution (US\$)
38	Greenhouse – State of the art review and performance evaluation of dehumidifier	52,080	26,230
39	Performance evaluation of brackish and seawater RO plants in Oman	28,051	28,051
40	System analysis of renewable energy conversion integrated with desalination processes	101,050	50,000
41	Improvements of techniques for assessing RO membrane colloidal fouling	218,505	110,000
42	A study of a hybrid fuel cell / desalination systems	202,792	121,358
43	Development of a web based computer package	67,500	67,500
44	Development and analysis of the diffusion driven desalination (DDD) process	140,381	70,000
45	Theoretical and experimental studies of flow throw narrow channels with inserts towards membrane module performance optimisation	228,957	112,760
		6,769,742	3,173,418



# WASTEWATER MANAGEMENT IN URBAN AND RURAL AREAS: A REVIEW OF THE ISLAMIC REPUBLIC OF IRAN'S EXPERIENCES

Seyed Ali Mahmoudian; Technical Studies Manager, National Water and Wastewater Engineering Co.,  
Ministry of Energy, Tehran, Iran; Email: seyedali@nww.co.ir

## ABSTRACT

The year 1990 is considered as a turning point in the water and wastewater management of Iran. In this year the *Act for the Establishment of Water and Wastewater Companies* was ratified by the Parliament and a water and wastewater company was set up in each province. Subsequently in 1995 the Parliament also approved the *Bill for Establishment of Rural Water and Wastewater Companies*, which were at first affiliated to the Ministry of Agricultural Jihad, and then in 2002 became affiliated to the Ministry of Energy, following a parliamentary revision. As a consequence of the above initiative, the national water and wastewater sector has experienced remarkable progress in the last twelve years and the figures for population access to potable water and sanitation have risen sharply. The country has also gained valuable experience both in the institutional and technical aspects of wastewater management in urban and rural areas, an overview of which is presented in this article.

*Keywords: sewerage, wastewater treatment, experiences, I.R. of Iran*

## INTRODUCTION

The protection of the environment and the control of pollution caused by exploitation of natural resources are of major concern to human societies. The undesirable ecological effects of improper discharge of urban and industrial wastewaters, in conjunction with the need for their recycling for sustained use in agricultural production, are so important that today the implementation of wastewater plans in the urban, rural and industrial areas of Iran is considered essential.

To this end, during the last decade remarkable activities related to the study and implementation of wastewater plants were undertaken, to the extent that wastewater projects are being executed in 167 cities and towns in Iran and relevant studies and design are continuing in 100 other towns. An examination of the documentation of plans used during the implementation process, the recording of events and the experience of applying different work procedures, as well as the comparison between project design, real-life performance and operation - including the technical, socio-economic and ecological impacts - have been found to be quite instructive. Thus, those initiatives taken to manage urban and rural wastewaters in Iran and some of the experiences gained in the management, institutional and technical fields are presented in this article.

## SEWERAGE AND WASTEWATER TREATMENT AND REUSE ACTIVITIES

### Existent conditions of urban wastewater discharge

By the end of year 2003, there were many wastewater projects either being planned or implemented in over 270 cities and towns, but still, in most urban areas (with the exception of the city of Isfahan and some others), wastewater was discharged to ground basins through absorption wells. The traditional wastewater collection systems were also available in around 75 towns and cities, but the raw wastewater was either discharged directly to watercourses or used for irrigation. Based on the efficiency of these systems and according to condition of wastewater discharge, the urban areas of the country can be divided into two groups.

The first group comprises the towns where the suitability of soil and climate make the traditional wastewater discharge currently tolerable. They are 300 mainly small towns, representing 24 percent of the country's population. The second group consists of towns where, due to either high level of water in ground basins or the impermeability of soil, discharging wastewater to the ground is not possible. In view of health hazards and environment protection, serious resolution should be taken immediately in this group to implement wastewater plans. This situation prevails in around 400 mostly large towns, home to 76 percent of the country's population.

Considering the increasing population, together with the relatively rapid development of urban areas and higher water consumption, the traditional wastewater discharge system has proved inadequate and has heightened problems in these towns, the most important of which are sanitation and environmental threats. They have resulted in outbreaks of infectious diseases, disruption of natural water balance, the rising level of ground water tables and the pollution of water resources.

### Performance and execution of wastewater plans

There are currently 267 wastewater collection and treatment plants in Iran, of which 100 are in the study phase and the rest are being executed in 167 towns by water and wastewater companies.

The performance for the establishment and expansion of urban wastewater networks until the end of 1999 (the target year for the Government's Second Five Year Economic, Social and Cultural Plan), reaches a figure of 14,528 km, including 3,500 km of traditional wastewater systems, servicing 5.76 million people. By reaching the target of 15,000 km of wastewater collection network set in the Government's Third Five Year Economic, Social and Cultural Plan, around 7.7 million people will benefit from wastewater services. This is outlined in Table 1 below:

Table 1: The situation of urban wastewater services

Item	Unit	Year 2004	Year 2020
Population coverage of wastewater collection network	Million	13.5	48.6
Percent of population covered in relation to the country's total	Percent	30	60
Length of Wastewater Collection Network	Km	29,528	123,000
Number of wastewater connections	Connection	2,284,000	9,530,000
Volume of produced wastewater	M3/day	2,379,000	8,000,000

## **Wastewater treatment**

To protect the environment and water resources from pollution and to reuse effluents, it is imperative to treat wastewater in Iran. According to the national standards, wastewater should be treated to reduce the levels of BOD and SS to 30 mg/l and 40 mg/l respectively. Currently 48 treatment plants with a total capacity of 0.921 MCM per day are operating throughout the country, treating the wastewater produced by a population of 4.9 million. There are also 89 treatment plants with total capacity of 2.235 MCM per day under construction, ready for operation by the year 2005. In Table 2 (see below) the number and capacity of plants operating, studied or under construction are listed according to treatment process.

## **Reuse of wastewater**

Using treated effluent to augment existing water supplies is becoming an increasingly attractive option. The advantages of wastewater reuse include: water pollution abatement (not discharging into receiving waters), reliability of water supply, water demand and drought management, encouragement for conserving resources and availability of highly treated effluent for various beneficial uses.

The reuse of wastewater has a long history throughout the world. Wastewater has been used for irrigation either through direct transfer by aqueducts to agricultural fields, or indirectly by discharging it to the river and conducting the water downstream to farms. The 48 wastewater treatment plants in Iran have a nominal capacity of 912,000 m<sup>3</sup> per day, 64 percent of which is for Isfahan alone. This city of 1,374 million people is the second largest one of the country, and the first to have a full wastewater collection system, dating from nearly 30 years ago. Wastewater in Isfahan is discharged into the Zayanderood River (the second largest in the country), and in other urban areas wastewater is disposed of in a similar fashion. Therefore, it can be claimed that in Iran today, all the treated wastewater is indirectly used in agriculture. Of course in some towns, albeit in a limited form, the raw wastewater is used directly for irrigation, resulting in some health-related problems.

As mentioned, around 70 towns - mostly situated in the west, north-west and north of the country (like Rasht and Ahvaz for example) - have a traditional wastewater collection system, due to their rocky ground or high level of water table. Here also the wastewater is often discharged untreated into existing floodways, a part of it infiltrating the ground and the rest used for irrigation downstream. The volume of this wastewater is estimated to reach 116 MCM per year.

In most towns and cities, despite ongoing projects for wastewater collection system, the main method for wastewater discharge is through absorption wells, and a part or all of the discharged wastewater reaches the underground water basins to be drawn and used for irrigation later on. As a result, there is a kind of artificial replenishment of ground basins in these towns. However, in some areas there are signs of pollution threatening the freshwater resources. For example, tests have shown that the nitrate content in groundwater resources of the city of Mashad to be 180 mg/l and that of Arak reaching up to 220 mg/l, which is many times more than the allowed limits. The volume of wastewater in this urban group is estimated to be around 2,829 MCM per year. Thus, as wastewater collection is implemented and treatment plants established, the indirect and unsafe use of wastewater changes into a direct and safe reuse.

## NATIONAL POLICIES, STRATEGIES AND ONGOING PROGRAMMES

To reiterate, Iran is on the brink of a water crisis. Over the past two years the country has experienced the severity of drought-instigated water shortage. To counter this crisis, the Government of Iran has included four essential actions in the national water management programs, as below:

- efficient and optimal use of available water resources;
- continuing effort to find new resources in the water cycle and maximum use of unconventional water;
- deep and far-reaching action to conserve freshwater resources and to prevent the pollution and destruction of water quality;
- expanding public awareness and implementing demand management programs.

The ongoing water shortage in the country has also forced many decision-making bodies to consider the reuse of effluent as an appealing option. Among recent decisions taken by the Expediency Council was the adoption and implementation of general plans for recycling water nationwide. Some of the proposed policies and strategies are as follows:

*Exploiting the drinking potential of freshwater to the full, prior to its use for any other purpose.*

To achieve this, it will be necessary for new urban water supply plans to pass freshwater, either from surface or ground resources, through cities so as to optimize their drinking potential and then the produced wastewater is to be allotted to the agricultural sector after treatment.

*Guaranteeing future urban water demands by replacing the agricultural water rights (from brooks, rivers, springs well, etc, which are of potable quality) with treated effluents.*

Towns faced with shortages of freshwater resources, are to negotiate with farmers so as to appropriate freshwater, and instead allot treated wastewater to farmers.

*Avoiding the use of high quality urban water to create green spaces, and instead allotting low quality water for this purpose.*

Each year in Tehran, over 50 MCM of raw (but potable) water is used to irrigate the forests in north-east and west of the city. A considerable portion of this demand can be alleviated by treated wastewater, and instead the potable water used for forestation can be added to the Tehran's freshwater potential.

*Cutting off water supply to industries, which have not taken practical measures to treat and reuse their wastewater.*

The most important related legal status - proposed in the Third Five Year Economic, Social and Cultural Development Plan and approved by the Parliament - is Article 134. According to this article, the issuance of new licenses or renewal of old licenses for exploitation of surface or ground resources or for obtaining a connection to the urban supply network by large production units, industries, animal husbandries, or services which produce a large amount of wastewater, will be subject to construction of wastewater treatment and recycling facilities by the said units.

*Expansion of research projects towards establishment of reasonable standards for safe and reliable reuse of wastewater.*

Replacing freshwater with treated effluents in agriculture necessitates introducing farmers to the positive and economic advantages of using wastewater, and consequently, convincing them to exchange freshwater with effluents. This in itself requires research and study on the sanitary,

economic and environmental impacts of using wastewater for agriculture and artificial recharge of ground resources.

## **EXPERIENCES GAINED**

During the last decade Iran has gained many experiences from its operation and management of wastewater, lessons and experiences which comprise a valuable asset for the nation's development as well as for that of other nations. Some of these are outlined in the following sections.

### **Institutional reforms: the Orbital Model Experience**

Until 1990, apart from urban water supply plans, which were to be implemented by the Ministry of Energy, all other water and wastewater related activities in Iran were carried out by provincial governments, municipalities and even independent organizations, all of which that worked in a dispersed and form. This state of affairs caused many problems and difficulties related to clean water and the sanitary discharge of wastewater for general use.

To control and improve this situation, it was decided that a serious review of the country's water and wastewater management be made. However, the question of governance remained at issue: would the Government or the private sector be in charge and what would be the division of responsibilities? Opting for a compromise involving both sectors, it was decided that the private sector should reform the management of the national urban water and wastewater sector. This meant that the Government would be in charge of coordination and capacity building as a monitoring body, with a minimum of direct involvement for maximum quality, while the private sector would handle the services and production affairs. To this end, constant efforts were made towards the establishment of water and wastewater companies 'non-governmental and decentralized' in character, leading to the ratification of the *Law for Establishment of Provincial Water and Wastewater Companies* in Parliament, marking a turning point in the country's water and wastewater management.

To establish provincial water and wastewater companies and to create independent water and wastewater networks in the cities of each province, as well as to shape the relations of these companies with the Ministry of Energy's headquarters, and the National Water and Wastewater Engineering Company, Iran formulated a model called 'the Orbital Model with Attraction Mechanism'. This model is based on the central directive of the Islamic Republic of Iran's operations, summarized in the following two principles:

- as far as possible, activities related to production of goods and services are to be handed over to people; and
- the Government's role is to be as the coordinator of all activities to establish the social equilibrium, and ensure the smooth operations of the economy.

Based on these principles, the responsibilities, rights, and interaction between the independent urban water and wastewater units were established.

Further, a number of conclusions can be observed from the above-mentioned model, which comprises oval shaped orbits, whereby the National Water and Wastewater Engineering Company is at the center of one such oval and the provincial water and wastewater companies are situated on the orbits.

When a provincial water and wastewater company attains a high level of capability and work potential, it can act more independently. Therefore, its distance from the headquarters increases and it will be moved to a higher circuit. Similarly, vice versa, when a company cannot be completely independent, it will be more closely linked with headquarters.

The same principle relationship is seen between independent urban water and wastewater units and their headquarters - the provincial water and wastewater companies - meaning that each urban unit with a high potential can distance itself from provincial headquarters.

It should be pointed out that within this organization, the water and wastewater engineering company is a governmental concern, affiliated with the Ministry of Energy, whereas the provincial and independent urban water and wastewater companies are non-governmental organizations.

Iran's twelve years experience of providing services through non-governmental organizations (provincial water and wastewater companies), whilst maintaining close governmental scrutiny (by the National Water and Wastewater Engineering Company) as outlined above, have proven to be an efficient and ideal management system. From the Government's experiences, lessons learnt include:

- reorganization leads to an evolution and prepares the grounds for further change;
- maximizing decentralization of activities enables local organizations to increase their decision-making capacity; and
- creating an equilibrium between the government, NGOs, and the private sector for current activities has been quite effective.

### **Institutional reforms: the privatisation experience**

Effective relations with the private sector, especially with the creation of the independent urban water and wastewater units, have been made possible via the following procedures:

- transferring the management of the independent branches to the private sector;
- relegating some secondary services (such as meter reading and connection) to the private sector;
- joint ventures with the private sector for the new installations.

Until now, Iran's experiences in transferring operations and maintenance of the water supply networks in Tabriz, the wastewater treatment plant in Mashad, the pre-pressed concrete pipe and concrete wastewater pipe factory in Tabriz, and other examples, show that for maintenance and operations at least, using the facilities of the private sector is an advantageous economical option.

### **Institutional reforms: project management experience**

In recent years, to expedite operations of water supply projects, newly established private companies have been employed as project managers, in addition to the presence of a consulting engineer. These companies, as trustees, take over client responsibilities, and act on the client's behalf in the executive planning, provisions, and many other matters. The use of this method, in few important water supply projects, has remarkably shortened the project execution time in a comparison to similar cases, and consequently, the true expenses of the project were considerably reduced. This has proven to be a very beneficial experience and it shall be further applied.

### **Technical experiences: study and design**

It is necessary to standardize fundamental parameters for the study and design of important projects. Since the designer's creativity should be directed towards addressing the essential issues and finding the best possible solution, rather than establishing general design parameters and collection of basic data, the compilation of study and design standards has been essential work undertaken by the Government of Iran during the last two decades. Our experience in this field involves the establishment of a National Centre for Water Engineering Standards, which has so far prepared over 500 standards, including regulations for the design of wastewater plans and typical drawings of the wastewater collection network components.

As for the quality of raw wastewater and the design criteria for wastewater treatment plants, we have gained valuable information based on our tests (conducted from 1988 to 2000) on the raw wastewaters in the Esfahan and Tehran Treatment plants. These results reveal that the average values of BOD<sub>5</sub>, SS and COD are 203, 214.7, 439.3 mg/l respectively, which, taking into account the per capita wastewater production of 150 to 200 l/day, would return the values of: 30.5 to 40.6 g/day for BOD<sub>5</sub>, 65.9 to 87.9 g/day for COD and finally 32.2 to 42.9 g/day for SS.

### **Technical experiences: sewerage systems in urban areas**

Currently, in 167 towns and cities of Iran, works on wastewater collection networks continue, all of which consist of separate and conventional gravity sewer systems. Moreover, the general concept in their design was to create a centralized system involving the collection of wastewater from a number of dispersed points to be directed towards a central treatment plant. For example in Tehran, which has a population of 7 million, wastewater is transferred from the extreme northern regions of the city (Shemiranat) to the southernmost point (a distance of approximately 30 km) to be treated in a maximum of three plants; or in Shiraz, a city of two million inhabitants, the length of the main trunk reaches a maximum of 35 km, which, in the event of a failure, would cause great problems.

The Government of Iran gradually came to understand that it should change from a centralized to a decentralized wastewater management system, meaning that wastewater should be collected and treated as closely as possible to its point of production or probable reuse. The perceived benefits of this include:

- employment of a combination of cost effective solutions and technologies;
- tailoring the solutions to the problems;
- reducing the freshwater requirement for waste transportation;
- reducing the risks associated with system failure;
- increasing the wastewater reuse opportunities;
- reducing the cost of collection systems significantly.

The Government of Iran plans to replicate this experience of decentralized wastewater management for the rest of the Tehran Wastewater Plan (approximately 50,000 hectares), as the cost of treated effluents within the city limits is at least equal to the raw freshwater (providing the possibility of replacing the raw water with treated wastewater for green spaces and flushing applications). In the extreme ends of the city it is equivalent to the price of agricultural water, roughly about ten times less expensive.

### **Technical experiences: sewerage systems in rural areas**

The common system of wastewater collection in rural areas is the small diameter gravity system (SDGS), which is applied in 243 out of 393 villages, for which a wastewater collection plan was prepared for 61.8 percent of cases. For the remaining 38.2 percent of villages, a simplified system (SS) was considered for 15.3 percent of villages and a conventional gravity sewers system (CGSS) was considered for the other 14.5 percent of villages. A further 8.4 percent of villages with dispersed houses will dispose their wastewater onsite.

Although Iran is still quite new to the execution and operation of rural wastewater plans, it is believed that the SDGS system, which is the most common wastewater collection system in rural areas of the country, causes less operational problems than other systems (an important factor in such areas). This reasoning is due to sedimentation of suspended solids in household septic tanks; and the impossibility of discharging solid wastes into the network by villagers through manholes (since the system does not include the construction of manholes).

## Wastewater treatment processes in urban areas

The major selection criteria for treatment process are:

- acceptable efficiency and productivity;
- simple operations and maintenance;
- compatibility with climatic conditions and freedom from undesirable environmental impacts.

In the initial years of monitoring water and wastewater companies' activities, Iran's principles were: 'the best is too good for us' and 'the best is the worst enemy of the good'. 'Modern' systems, which were mostly mechanical and needed foreign exchange resources for execution and expertise in operation, were avoided. Thus, through circulars and guidelines, water and wastewater companies were encouraged to opt for natural and non-mechanical processes of wastewater treatment. However at later stages, due to human resources capacity building and the increase in companies' revenues and financial resources, the constraints for the use of new and modern systems were removed. As a result, today, the issue is not so much selecting advanced, specialized systems, but rather, thinking more in lines of compliance with general standards in terms of environment, cost effectiveness and access to new technologies. Accordingly, in 137 plants (48 operating and 89 under construction), the selected treatment processes are depicted in Table (2) below:

Table 2- The number, capacity and treatment processes of urban wastewater treatment plants

Treatment process	Number	Capacity (1x1000m <sup>3</sup> /d)	Population (thousands)	Percent	
				Number	capacity
WSP	42	670	3,374	30.7	19.00
Wetland	1	5	25	0.7	0.14
A.L.	32	651	3,158	23.4	17.76
Ex. A.	28	180	874	20.4	4.91
AS/PST	31	2,192	9,966	22.7	56.02
Biolak	1	48	250	0.7	1.40
SBR	1	10	50	0.7	0.28
USBF	1	17	85	0.7	0.49
Total	137	3,773	17,782	100	100

As can be observed, as far as capacity is concerned, 19.14 percent of the plants use non-mechanical processes, 17.76 percent use semi-mechanical and 63.1 percent use mechanical processes. Despite emphasis on the simplicity of operations during the initial year of the companies' establishment and operation, by taking into account the special conditions of the plant area, over 25 percent of treatment plants (as far as their number is concerned) are 'advanced' and need relatively high expertise for their operation. Nevertheless, the simple treatment systems (WSP) have proved satisfactorily efficient, especially in warmer regions, except in areas with problems of mosquitoes or high algae growth.

After years of operating three wastewater treatment systems using the activated sludge process, the city of Esfahan has chosen to build its fourth plant, which will be of 1,000,000 PE in capacity, based on the stabilization pond process, and currently its first module (of 500,000 PE in capacity) is under construction. To simplify and reduce investment costs of activated sludge process, our consultants have brought about innovative modifications, a number of which are mentioned below.



## **Modification of Zahedan Wastewater Treatment Plant**

With a service capacity of 1,000,000 PE (people), the Zahedan Wastewater Treatment Plant was originally designed and studied for a conventional activated sludge process. However, taking into account the suitable geographical conditions of the locality and the availability of land, the plan was modified by the elimination of anaerobic digesters and the inclusion of a transmission line - 6 km in length - to transfer the sludge from the plant to a stabilization lagoon. This modification led to \$5,000,000 USD savings on the original costs.

## **Lagoon Activated Sludge System (LASS) Process in Khoram Abad**

Based on the original plan, the Khoram Abad Wastewater Treatment Plant - with a capacity of 200,000 PE - was constructed in two modules using aerated lagoon systems followed by anaerobic tanks. During the extension plan, and taking into account land limitations, the activated sludge system was chosen and is to be used by a population of around 200,000. However, the possibility of combining the two processes of aeration lagoon (modules 1 and 2) and activated sludge (module 3 and 4) were studied by applying value engineering principles, and a suitable and relatively new process known as LASS was introduced.

In this combined method, all the sludge processing units, such as thickeners, digesters and dewatering units are eliminated, and the additional activated sludge as well as the sludge produced in the primary sedimentation tanks are discharged into the anaerobic and the aerobic lagoons of modules 1 and 2. In general, precise stages are followed during the application of combined activated sludge and aeration lagoon processes: 1) elimination of sludge processing stages in the activated sludge system; 2) transfer of primary sludge to anaerobic lagoons; and 3) transfer of surplus secondary sludge to aeration lagoons and increase in sludge age.

This system is suitably flexible for the organic and hydraulic loads and has a good BOD, ammonium and nitrogen removal efficiency, with the following additional advantages:

- saving on land requirements (30 hectares);
- 2,500,000 Euros saving on capital investment during the construction of the plant by eliminating sludge digesters in modules 3 and 4;
- annual savings of 200,000 Euros on operational expenses due to complete elimination of sludge digestion process;
- easy operation and maintenance, especially in sludge collection units of the activated sludge process;
- high efficiency of aeration lagoons as result of increased biomass, increased capacity of these lagoons, and improved effluent quality.

## **Biolak process in Uroomieh**

The initial plan for the Uroomieh Wastewater Treatment Plant (of capacity 200,000 PE) involved the partial mix aeration lagoon process, which was put on tender for execution. Around 32 hectares of land was required, but since the land was clayish and of low resistance ( $0.25 \text{ kg/cm}^2$ ), it also needed consolidation, for which a vertical drainage system was considered. During consolidation, imminently huge expenses (around 3.8 million Euros) and longer execution time were required for the project. During the initial stages of the works when a new method called Biolak came to our attention. The Government of Iran therefore asked the bidders to contact the patent holding company in Germany and propose this treatment process as well. In the end, the Biolak system won the tender. This implied:

- a considerable reduction in the size of needed land: from 32 hectares to 7.2 hectares;
- 78 percent reduction in costs of land consolidation;
- 1,600,000 Euros savings on the costs of plant construction;

- o reduction in construction time.

### Wastewater treatment processes in rural areas

The main criteria for selection of wastewater treatment processes in Iran's rural areas are the simplicity of operation and maintenance of the plant. Therefore, as shown in Table 3 (below), in over 64.8 percent of plants, the waste stabilization pond and the constructed wetlands processes were selected. Moreover, in villages with dispersed residential areas, onsite decentralized systems had more justifications, representing 8.4 percent of the total projects. With a few exceptions, the rural wastewater treatment plants are currently in the design stage. Although experience of their operations is negligible, it is believed that at the moment the natural and onsite treatment processes could be the best choice.

Table 3: The number, capacity & treatment processes of Rural Wastewater Treatment Plants

Treatment process	Year 2003 (design stage)			Percent		
	Number	Capacity (1x1000 m <sup>3</sup> /d)	Population (thousands)	Number	Capacity (1x1000 m <sup>3</sup> /d)	Population (thousands)
WSP	166	88.4	978.8	42.4	65.7	67.0
W. L.	88	28.1	278.6	22.4	20.8	19.1
A. L.	8	2.7	38.3	2.0	2.0	2.6
Ex. A.	46	3.7	52.4	11.7	2.7	3.6
SBR	1	0.6	4.7	0.2	0.4	0.3
T. F.	4	1.7	17.3	1.0	1.3	1.2
ST + SF	23	1.0	11.0	5.8	0.7	0.7
On site	33	0.7	7.5	8.4	0.5	0.5
Others	24	7.9	73.0	6.1	5.9	5.0
Total	393	134.8	1461.6	100	100	100

### Technical experiences: source control sanitation systems

Source control sanitation systems involve the separation and appropriate use of wastewater components at their point of origin, and consequently prevent the pollution of water resources. The concept proposed by Uno Winbald (1997) - "*Don't mix faeces, urine, water*" - has provided a new paradigm in considering sanitation. The design of source control sanitation aims for a high hygienic standard, full reuse of resources and the closing of the water and nutrients cycles. This can be achieved by separating different qualities of wastewater from human settlements, like black water (toilet wastewater) and grey water (washing, cleaning).

The typical characteristics of streams of household wastewater clearly reveal that urine contributes about 87 percent of nitrogen, 50 percent of phosphorous and 54 percent potassium to the domestic wastewater, whereas greywater, despite its very large volume compared to urine, contributes only about 3 percent of nitrogen, 10 percent of phosphor and 34 percent of potassium. Therefore, domestic waste without urine avoids the costly nitrification–denitrification process. Furthermore, greywater can be treated with simple biological methods and reused for many purposes. Faeces, which is 10 times smaller in volume than urine, contains high organic load and pathogens, which kill millions of people annually worldwide. Faeces, however can be sanitized and used as soil conditioner, whereas urine can be treated and used as fertilizer.

Source control sanitation systems have been successfully implemented in countries such as Sweden, Austria, Germany, Denmark, China and Canada. Based on their experiences, the system can be recommended for most conditions and has a priority over the conventional system. A pilot research project is ongoing in Iran in cooperation with the Achen University of Germany.

**CONSTRUCTION EXPERIENCES: OVERVIEW**

Over ten years we have executed over 17,000 km of wastewater collection networks in Iran, involving pipes of 200 to 2000 mm in size. We have worked in different soil conditions (high groundwater tables, risk of landslides, rocky soil and generally under good and bad working conditions) and we have gained many valuable experiences, which are presented briefly below.

**Construction experiences: consolidation of land by prefabricated vertical drain**

The geotechnical tests conducted on the site proposed for the construction of the Uroomieh Treatment Plant showed that granular materials composed the soil layers up to a depth of 25 m, the soil resistance was very low (0.25 kg/m<sup>2</sup>) and the level of groundwater tables was about one meter below the ground. Therefore, considering the load exerted by the weight of liquids and structures, which corresponded to 0.5 to 0.6 kg/cm<sup>2</sup>, the land had to be consolidated. This involved the use of prefabricated vertical drains of 10 cm in width, 5 mm in thickness and 70 g/m in weight. Drains were driven to a depth of 15 m at a distance of 2.25 m from each other, forming triangles, and covered by local soil up to 6 m above the ground level. Based on these measurements, the maximum land subsidence in a period of eight months was about 80 cm. The cost of the above operations amounted to 120,000 Euros per hectare.

**Construction methods: overview**

The open trench method is the most commonly applied process in the execution of wastewater networks. If the soil type is suitable and the level of groundwater table is below the project line, the execution of wastewater pipelines using the open trench method is quite practical. However, in areas where the soil type is weak and the groundwater tables are high and close to ground level, the open trench method is impractical and coupled with many execution difficulties. An increase in the depth of excavation in this case would make the sliding of trench walls an uncontrollable matter, requiring the widening of the trench, and a proportional increase in the costs and executive problems of the works. In such cases, the open trench methods used for execution of wastewater pipelines are avoided and instead the trenchless methods are used. Based on local conditions, both methods were applied to different urban areas of Iran and the comparative volume of works undertaken by these methods is depicted in Table 4, below:

Table 4: Comparison of wastewater works undertaken in Iran

No.	Mode of execution	Diameter (mm)	Length (km)
1	Open trench	200-2000	27000
2	Trenchless:		
	Manual dig	250-1600	1680
	(traditional)	400-1600	78
	Pipe jacking	200-600	20
	Microtunnelling		

The methods to execute sewers under different work conditions include the procedures to protect the trench wall and pre-drainage methods to lower the groundwater level and control the water table until the end of the operations. The methods used in Iran are shown in Table 5 (below). Except for the

traditional tunnelling method, which comprises 80 percent of the executive works on the Tehran wastewater network, and is explained in detail here, only the results obtained from others are presented in this article.

### **Construction methods: execution of sewers by traditional tunnelling method**

This traditional tunnelling method evolved from an indigenous technology which dates back 2000 years and for which there are many specialist master builders in Iran. It has been applied to install pipes of 250 mm to 1600 mm in Tehran’s sewerage system.

According to this method, the vertical shafts are dug at distances of five to seven metres from each other between two consecutive manholes, depending on local conditions. Then the shafts are connected together by manually dug tunnels, and the tunnel section is widened and adjusted in proportion to the sewer pipe. In cases where the ground is not sufficiently stable and safe, preventive measures are taken by installing blocks, woodpiles or concrete rings. Thereafter, on the basis of the subsurface conditions and plan’s specification, the necessary bed works are undertaken and the sewer pipes are conducted through the shafts, into the tunnel and installed. As polyethylene pipes are used for sewer diameters of up to 400 mm, they are welded beforehand and the integrated pipe is conducted into the tunnel, to be installed in the distance between two manholes. Taking into account the visco-elastic character of these pipes, the above operation is only possible using single wall poly ethylene pipes. To install double-walled pipes, a single pipe of six to twelve metres in length is pushed into place and the connections are made inside the tunnel using couplers, o-rings or expansion joints instead of welds.

To facilitate the movement of pipes inside the tunnel, a new excavation is made above the shaft at the site of first manhole called the pipe transfer hole. For concrete pipes of 500 mm and over, after transferring a single pipe of one to two metres in length, the installing operations are undertaken inside the tunnel and the pipes are joined together using o-rings. The course alignment is controlled using a mason’s rope. After completion of pipe installation the empty space in the drilling site is filled by a suitable material, as per the design specifications, covering the pipe up to a height of 10 cm, and the remaining space is filled through the shaft with either lime mortar for laterals or C25 concrete for sub-mains and the main sewers. The manholes are constructed after pipe installation.

Since occasionally the empty spaces over the pipes are not filled completely by gravity in gentle slopes, a gradual land subsidence occurs along the pipe course, unavoidably needing repairs and rehabilitation works. To alleviate the problem, the condition of fillings around the pipes is controlled and observed using geo-radar equipment. The traditional pipe-laying method needs simple masonry tools and can be executed simultaneously at different fronts. As mentioned, over 80 percent of the Tehran Sewer Works involve this method. The greatest advantage of this method lies in that it has the least impact on the busy traffic in Tehran when compared with the open trench method.

Table 5- Methods of executing sewers under different work conditions

Execution method		Supporting method	Work condition
1- Open Trench	1-1- Without support	-	Appropriate soil and groundwater tables lower than the pipeline mostly at depth of 1.5-2.5 m
	1-2- Supported excavation	1-2-1-Use of wood piles	Sand soil conditions, narrow and shallow trenches mostly at depths of 2.5 m max
		1-2-2- Use of metal supporters	High groundwater tables, narrow and shallow trenches at depth of 3 m max.

Execution method		Supporting method	Work condition
		1-2-3- Use of steel sheet piles	Collapsible soil, need for vertical wall trench, high groundwater table and high water inflow, clayish soil and risk of swelling of the trench floor
	1-3- Methods of reducing groundwater tables	1-3-1- Pumping from a ditch	Existence of sufficient slope, narrow and shallow trench, soil of appropriate granulation
		1-3-2- Sheet pile driving and pumping	Collapsible soil, deep trench and high groundwater table
		1-3-3- Drilling deep wells	High groundwater table with high permeability
		1-3-4- Well point	Need for significant lowering of groundwater table
2- Trenchless	2-1- Manual tunnelling	Wood piles or concrete steins	Low groundwater table, soil stability
	2-2- Pipe jacking	Shield, wood pile or shields (in shafts)	Impossibility of manual tunnelling due to collapsible soil and deep sewers, mostly short lengths and large diameters
	Microtunnelling: At new sites for worn/ old pipes		Mostly medium to small diameter and length

### Construction methods: Pipe jacking and micro-tunnelling

In this method pipe installation operations are undertaken without the need for excavating the soil (except at shaft point) by driving the pipes. Pipe jacking is a new technology in Iran used mostly to install main sewers of 1200 to 1600 mm in diameter. The use of this method, especially for short distances such as passing under a heavy traffic junction or urban substructures like canals and water tunnels, has become quite common. When the soil is collapsible or of inappropriate material, and the pipe is to be installed relatively deep, the problems of common methods such as an open trench or traditional tunnelling increase, while the work-safety ratio decreases. Under such conditions pipe jacking is among the acceptable solutions. The different systems of digging include manual or mechanical diggings, with the latter needing larger shafts than the former. The main disadvantage of pipe jacking lies in its need for a wide corridor for execution, as minimum widths of four to six metres are needed to install the send-and-receive shaft. Pipe jacking is undertaken in two different ways: a) pipe jacking at a new location; and b) pipe jacking in old pipes.

### Comparing the open trench method accompanied by pile driving and the pipe jacking process

The major advantages and disadvantages of executing sewers by open trench accompanied by the pile driving method or by pipe jacking are summarized in Table 6, below:

Table 6: Advantages and disadvantages of executing sewers by open trench accompanied by pile driving method or by pipe jacking

Description	Trench and pile driving	Pipe jacking
Risk of destroying or damaging adjacent buildings	More	Less
Risk of destroying or damaging urban infrastructures	More	Less
Destruction of asphalt and related costs	High	None

Description	Trench and pile driving	Pipe jacking
Social impact of destruction of the course on local inhabitants	High	None
Traffic disruption	High	None
Occupation of space during works	More	Less
Cost of execution	More	Less

Taking into account the above explanations and experiences gained on installing pipes by these two methods in different Iranian cities, pipe jacking is much more preferable to the open trench method with sheet pile driving in sandy or collapsible soils, or in locations where groundwater tables are high with intensive percolations, or when there is a very heavy traffic load and should be used for depths of 2.5 metres and above. The cost comparison of the two methods is depicted in Table 7 below:

Table 7: Comparing the cost of executing sewers by open trench supported by sheet pile with pipe jacking in Abadan and Khoramshahr

Diameter of polyethylene pipe (mm)	200	250	315	355	400	450
Cost of pipe jacking (A)	90.2	94.7	100.3	105.6	110.1	119.1
Cost of pipe installation (B)	114.5	117	121.1	123.9	128.2	132.1
Percent (A)/(B)	78.8%	81%	82.8%	85.2%	85.8%	90%

### **Including the costs of procurement and execution of pipes in Euro.**

The experience of executing the pipeline by the open trench method with pile driving in the Bandar Abbas Wastewater Project showed that, in addition to being a very slow process (on average 2 pipes of 2.5 m in length and 1600 mm in diameter every five days), it was also very expensive. According to the bill of quantities for wastewater collection networks in the year 2004, this method would cost about 200 Euro per pipe meter.

### **Executing sewers by well point method**

Another method used in cases where the depth of pipe installation is lower than the groundwater table is the well point process, which allows the protection and stabilization of the trench walls and prevents their collapse.

This method was first used in the Bandar Abbas Wastewater Collection Plan. The experience proved that in addition to reducing the width of the trench and need for excavation works, the speed of installing pipes by this method was much higher than those using for instance shields or pile driving.

In Bandar Abbas, the pumping operation followed the digging of boreholes, installation of the suction pipes and their connection to the main and suction pipes. The pumping operations lasted for ten days to lower the level of groundwater tables. Thereafter, the digging and excavation works for sewer pipes began at the same time as the well point operations in the downstream and along the course, which needed only five days to complete.

The efficiency of pipe installation through this method is approximately 10 meters per day for pipes of 1000 mm in diameter, costing about 70 Euros in the current value (as at their current value and excluding the prices of pipes and pipe laying). It goes without saying that the well point operations and the speed of pipe laying works fully depends on the natural conditions, depths of operations and the diameter of the pipe.

### Construction methods: Drop manholes on main sewers

Due to the great north-south slope in Tehran and the limitation of executing sewer slopes, the use of drop manholes on main Tehran Sewers and their laterals are inevitable. For the laterals, Iran's Planning Organization recommended manholes be used, in which the wastewater drop is achieved through pipe joints such as T-joint and bends located inside the manhole space. For manholes inside the main lines (1000 mm in diameter and over) the wastewater drop occurs in the inner space of the manhole. After studying a number of methods for the design and construction of drop manholes, the use of different prefabricated large concrete sections and construction of typical drop manholes with a drop of around 1.5 metres was the method selected for Tehran Wastewater. The USBR Publication Type III was used to design the ramp dimensions and the settling tank. In cases where the conditions dictate a drop height of over 1.5 m, the larger manhole is constructed on site using concrete.

### Construction methods: Innovative systems:

In the last two decades, the need for using scientific and innovative methods of collecting wastewater, which under normal conditions would be more economical than the conventional gravity systems was felt. These methods are:

- Small Diameter Gravity System (SDGS)
- Vacuum System (VS)
- Pressure System (PSS)

The library research and the experiences gained in other countries show the following:

- The costs of executing the different wastewater system and choosing the most economical one depend on the two factors of population density and local topography;
- For a population density of normal to high and appropriately sloped topography, which ensures a gravity flow without the need for lifting stations, the conventional sewers will have the least expenses;
- In a low density area and zero or negative slope regions the pressure sewer systems (STEP or GP) are the most economical systems;
- In areas where, due to high groundwater table or the existence of bedrocks, the need for digging deep trenches is very high, the vacuum sewers are most economical systems for low to zero slopes and high population density zones.

In 2000, for the first time in Iran, as part of the feasibility studies of the Kenarak Wastewater Plan, a comparison of the above methods was made with conventional wastewater collection networks. Kenarak is located on Oman Sea coast and will have a projected population of 300,000 people in the Plan's target year (2021). Although the city lacks a slope, it has a high groundwater table. The cost estimates for different wastewater collection networks and their comparison with conventional systems are shown in Table 8 below:

Table 8: A cost comparison of different options (Figures in Euros)

No.	Network type	Cost of execution	Annual costs	Per capita costs
1	Gravity Conventional System (CS)	2,731,100	314,100	102.3
2	Small Diameter Gravity System (SDGS)	2,945,000	326,600	107.1
3	Vacuum System	2,610,000	460,600	98.3
4	Pressure System with Grinding Pump (GP)	3,559,000	595,200	129.9
5	Pressure Pump with Septic Tank (STEP)	3,500,600	580,700	125.6

In Anzali, a city in the north of the country on the Caspian Sea Coast that has a population of 200,000, the level of groundwater tables is high (less than a meter). The wastewater collection network was designed as a conventional gravity type and execution works began accordingly. The land was collapsible and digging a trench in depths of over 1.5 m without pile driving was impossible, slowing

the project's progress. It was therefore decided to use pipe jacking for the execution of the main lines and the vacuum system for the execution of the laterals. The necessary measures were taken accordingly and now all the three methods are being executed.

The following results were obtained so far from Anzali's experience:

- the vacuum system is cheaper than the open trench with pile driving and pipe jacking.
- pipe jacking is cheaper than the open trench with pile driving method, and offers more advantages taking into account the special conditions of Anzali

Further, in addition to being more economical, the vacuum system is easier execution due to the shallow depth of pipe installation, has higher speed, avoids hindering other urban infrastructures, and avoids the need for sheet pile driving.

Generally speaking, in Anzali the execution of sub-main and main lines are achieved through the simultaneous use of pipe jacking (for passing through dense and heavy traffic areas), open trenches (open areas of the town) and a vacuum system for the execution of laterals networks in older regions and dense areas, as they are found to be more practical, more economical and cause less social difficulties.

### **Experiences in reuse and substitution of treated effluents in agriculture**

With a population of two million, Mashad faces a dire shortage of water resources. The groundwater reserve in Mashad Plain, which is the main source of potable water supply in the city, is also under serious threat. It was therefore decided to study the plan of substituting the water wells of drinking quality, which belong to farmers, with treated effluents. For this purpose, a research project on the use of treated effluents for irrigation of the regional crops (beetroots and vegetables consumed raw) was defined and implemented in cooperation with the Ferdowsi University of Mashad. The objective of the research was to convince the farmers to exchange well water with treated effluents on the basis of the project's results. The research continued for one full cultivation period, leading to the results outlined below (note: the results are still not conclusive and need to be repeated for some years):

For carrot production, the use of treated effluents resulted in an additional four tons yield per hectare or equivalent to the yield achieved by the application of 25 tons of manure. The crop irrigated with effluents was contaminated with parasite roes and fecal coliforms, but the quality of the product itself was in no way affected. Moreover, irrigation with treated effluents had changed neither the physical nor the chemical characteristics of the soil.

On tomato farms, there was a considerable increase in yield (28 tons per hectare) in comparison to the reference crop. There were no signs of sanitary pollution and the quality of the product was not affected.

For cucumbers, the use of effluents resulted in an increase of 14 tons per hectare of crop, a value which is equivalent to the application of 25 tons per hectare of manure. The cultivation method, in which the bushes were not in contact with the treated effluent, caused no sanitary pollution.

On beetroot farms, compared with those irrigated with normal water, the use of treated wastewater has considerably increased both the quality and the quantity of the crop, to the extent that during tests, the sugar yield of beets was 2.36 times more than the samples irrigated with well water.

Following the above research, intensive technical, economic and social studies were undertaken, and the plans for transferring the treated effluents to farms and the transfer of agricultural well waters to Mashad were prepared. After ascertaining the feasibility of the plan and repeated negotiations with farmers to obtain their agreement, the executive operations began and are continuing. According to this plan, 150 million m<sup>3</sup> of effluents treated in Mashad Wastewater Plant shall replace the agricultural



water of potable quality. From this total approximately 50 million m<sup>3</sup> will be exchanged for agricultural water in the East and 100 million m<sup>3</sup> will be exchanged with agricultural water in the West sides of Mashad. After the necessary studies, the remaining effluents amounting to 130 million m<sup>3</sup> are considered as a potential source for artificial recharge of ground aquifers.

## **Value Engineering**

Value engineering is a problem-solving powerful tool and helps reduce costs of the plants while maintaining or improving their quality and efficiency. The Iranian Association of Value Engineers was established to facilitate the application of different methods of value engineering and a considerable number of plans have been studied in the value engineering workshops, one of which is the wastewater plan concerning the East Esfahan Wastewater Treatment Plant.

This treatment plant, which will have the capacity to service 1.5 million people (PE) by the year 2021, was designed for stabilization pond processes, and executive works on the first module of service capacity 750,000 people were already started. Upon the request of the Esfahan Water and Wastewater Company, the Iranian Association of Value Engineers conducted a value-engineering workshop for the above plan, the results of which are summarized below:

### *a- Treatment units in the base plan*

The anaerobic pond: three 500,000 PE modules each in two 250,000 PE phases

The Facultative pond: Six 250,000 PE facultative pond, each including three series of ponds.

Method of design: design based on the temperature during the coldest months of the year.

### *b- The units of options proposed by value engineers*

Anaerobic ponds                      3 units

Facultative ponds                      2 units

Design method – the ponds will be designed on the basis of summer temperatures and the deficiency of oxygen will be compensated for by aeration in winters.

### *c- Cost of execution*

Cost estimation for the modified base option is 32,910 and for the proposed option is equivalent to 31,000 million Rials.

### *d- The amount of savings*

The proposed option will involve 1,910 million Rials in savings in comparison with the proposed option.

### *e- The saving to Value Engineering Workshop ratio*

The total saving is equivalent to 1,910 million Rials why the costs of Value Engineering Group amounted to 37 million Rials. Therefore the return rate of investment on value engineering studies is over 50:1.

## **CONCLUSION**

Documenting plans, especially during the work execution stage and plan evaluation during operations, is extremely importance. In addition to providing a chance to revise the design criteria and standards, documentation enables information dispersal that would make the experiences gained available to all interested and relevant parties. Such exchange of best practice could result in extremely positive externalities, and a wealth of experience to help other countries faced with similar circumstances.

# **SUPPLY AND CONSUMPTION MANAGEMENT IN MEGACITIES: EXPERIENCES RELATED TO MEGACITY OF TEHRAN**

Sattar Mahmoudi, Tehran Water and Wastewater Company; Email: S-Mahmoudi@thr-ww.com

## **ABSTRACT**

In this article, the current situation confronting the management of water resources in the megacity of Tehran is explored, including future challenges, and those policies undertaken to manage the challenges, in order to safeguard and promote the splendor and vitality of the mega city of Tehran.

Population growth, the creation of mega cities and increasing demand for water are some of the most serious challenges for the management of population centers in various countries. Most mega cities in the world are faced with multiple problems when it comes to improved management of water resources and the creation of safe cities, each having their own special experiences. Some of these experiences - which can be very expensive - can to some extent be of use in other mega cities.

Due to water crisis of 2001 and constant shortages of adequate volumes of water, the megacity of Tehran has gained some valuable experiences, which could be utilized for future planning. In this article, we hope we can properly express some of the experiences and views of water management in this mega city, so they can be of benefit to others.

*Key Words: Consumption increase, Mega cities, Population increase, Scientific and practical approach, Water consumption management, Water resources limitations, Tehran Experiences.*

## **INTRODUCTION**

Population growth, development and the necessities of urbanization have made the creation of large and mega cities inevitable. At the beginning of twentieth century, the number of mega cities in the world was about ten, but now at the beginning of twenty-first century, this has increased to 65.

When considering mega cities, a range of efficient and non-efficient ways of managing them comes to mind, as mega cities contain simultaneous challenges and opportunities relating to public services, security, public health and the environment. Some mega cities can have enormous effects outside of their geographical boundaries, and in some cases, even outside of borders of the countries in which they are located. Therefore, paying attention to the various issues related to mega cities, particularly from an environmental and water resource management point of view, is extremely important.

This article thus examines supply and demand management of water resources in mega cities, with an emphasis on the location and experiences of Tehran. Many solutions and experiences gained and used from and during the process of facing these challenges, and also varied actions related to supply and demand management which were taken, can be utilized and applied to other mega cities and large cities in the world, especially developing countries of the middle east, because of their similarities in terms of social, geographical and climate conditions.

## TEHRAN'S WATER SUPPLY AND CONSUMPTION MANAGEMENT

With more than seven million permanent residents and two million non-resident commuters, Tehran is the sole mega city in Iran, constituting the largest population base in Iran and the eighth largest city in the world. It could therefore be considered a miniature of Iran: in terms of its cultural diversity and other characteristics, it is replete with symbols and phenomenon from all corners of the country. Yet as a mega city, it is also an important political hub for high ranking decision makers in Iran and foreign embassies and enjoys freedom of the press and freedom of public opinion.

Almost 26 percent of all activities in the country related to the water and wastewater sector are conducted in Tehran. The city itself is also faced with serious water-related challenges as Tehran is not constructed close to any large river thus its water resources are very limited and consumption patterns are very high. Thus in addition to these challenges of water availability and consumption are added challenges of cyclicity of water and climate (drought and rainy seasons) and increasing numbers of people living in the city outskirts. Further, it has been noted that there is difficulty in meeting demands of public services at appropriate levels in terms of quality, customer rights and safety factors involved in their delivery. Thus there is also a need for increased inter-organizational cooperation for effective water and waste management.

In order to manage the water in this mega city, large investments of time and money have been spent to build the capacity of the city to manage its water resources effectively. Thus the experiences gained during the 2001 water crisis constitute a case study and have created an excellent opportunity to be able to predict and correct problems and devise effective solutions, both for periods of water shortage and general urban water consumption management. These experiences were gained at high costs and high social risks and demonstrate how serious problems related to the management of water in mega-cities can, in fact, threaten their long-term viability if solutions are not found. Thus, by sharing Tehran's experiences it is anticipated that other mega cities, both regionally and globally, can potentially avoid the repetition of problems.

Some such challenges faced in Tehran include:

- limited water resources;
- spread of different pollutants threatening water resources;
- population growth and lack of a defined population ceiling;
- increased consumption and lack of planning or focus on consumption patterns and management;
- endless horizontal and vertical development (of people, city, etc);
- uncoordinated construction activities
- partially executed projects and accumulated expenses (impeding project completion);
- low water tariffs and limited financial resources
- increased industrial and urban wastewater and sewerage;
- a lack of new urban water telemetry and tele-control system capable of executing commands for supply cut-off, regulating distribution flows, and the distribution of urban water. The modern section of this system is ready for operation.

The biggest challenge faced by Tehran was the limited water resources. In 1931 when the population of the province of Tehran was less than one million, the amount of renewable water per capita was about 6000 m<sup>3</sup>/year. Comparatively in 2004, for a population of 11 million, this number has dropped to about 500 m<sup>3</sup>/year. By 2025, for a population of 15.5 million this figure will be reduced to 400 m<sup>3</sup>/Year, highlighting the water supply crisis situation. These trends are demonstrated in the diagrams below.

Figure 1: Per Capita Potential of Renewable Water Resources in Tehran

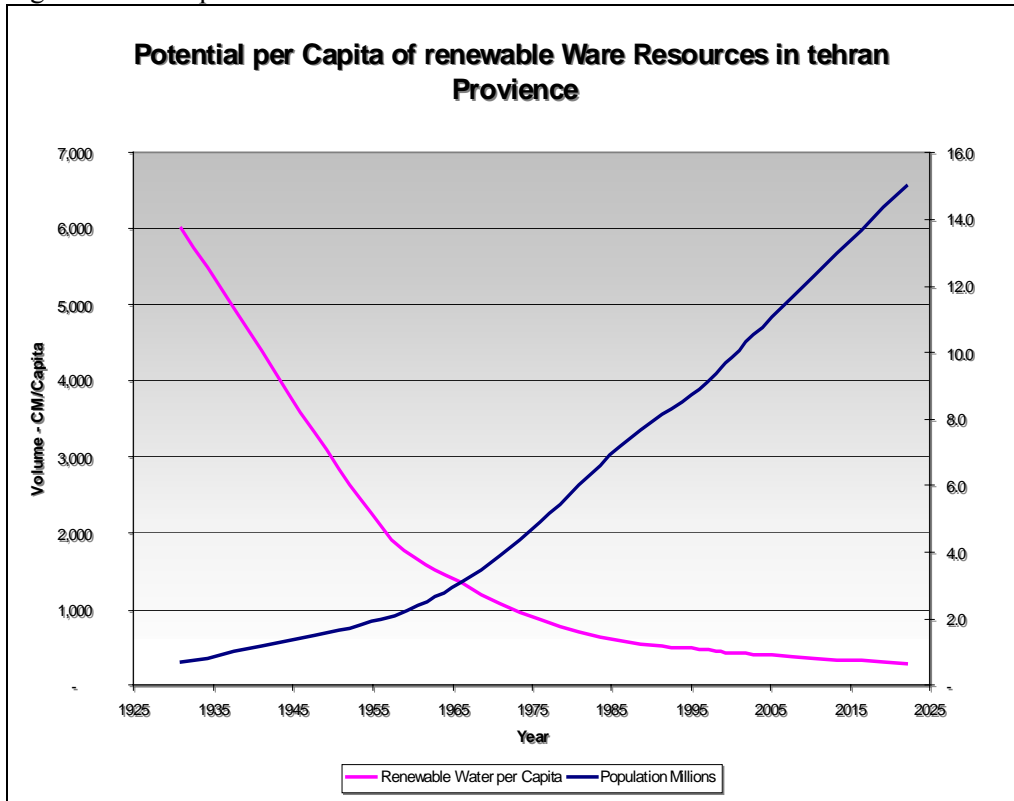

One of the main reasons for the unsustainable water supply in Tehran is its cyclical dry and wet seasons. Based on statistics which exist for Tehran’s watershed area for the last 60 years, during 40 percent of this period Tehran was faced with drought. For a mega city like Tehran that has a huge and burgeoning population, this phenomenon is a serious challenge.

Figure 2: Tehran’s Drought Situation over the past 60 years

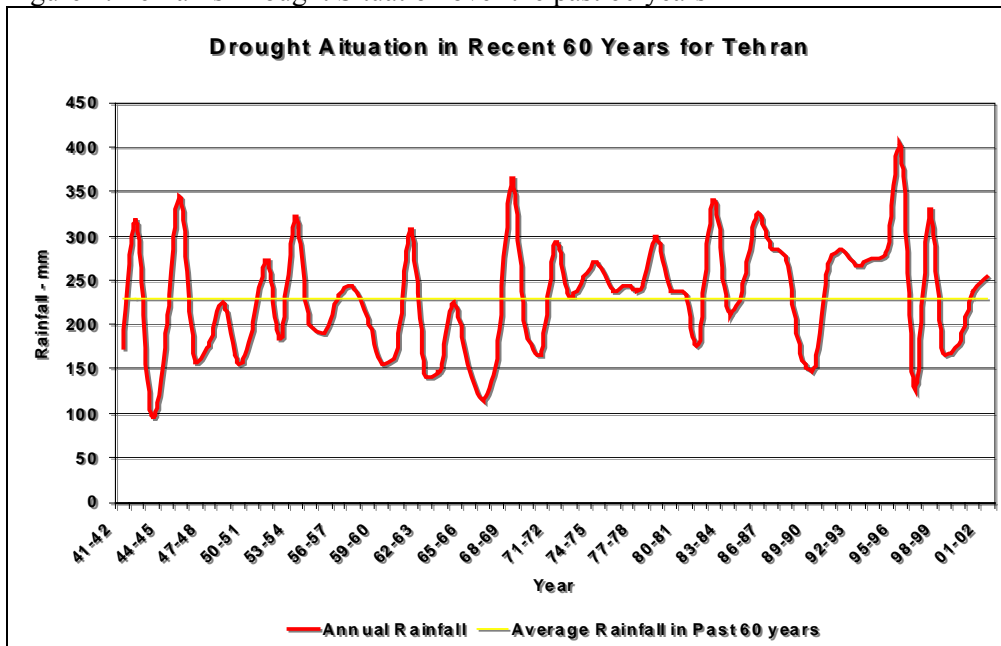

Modern and traditional living around the outskirts of Tehran, in the areas outside of legal city limits, creates additional challenges. But whereas ‘outskirts living’ often denotes huts, shanties and houses build without proper architecture, in Tehran, the reality is completely different: it means strong and engineered construction and rapid development. In Tehran’s outskirts, large engineered buildings have been built or are being built, supported by large investment, and continuous growth is anticipated. These trends are shown in the images below.

Figure 3: City expansion

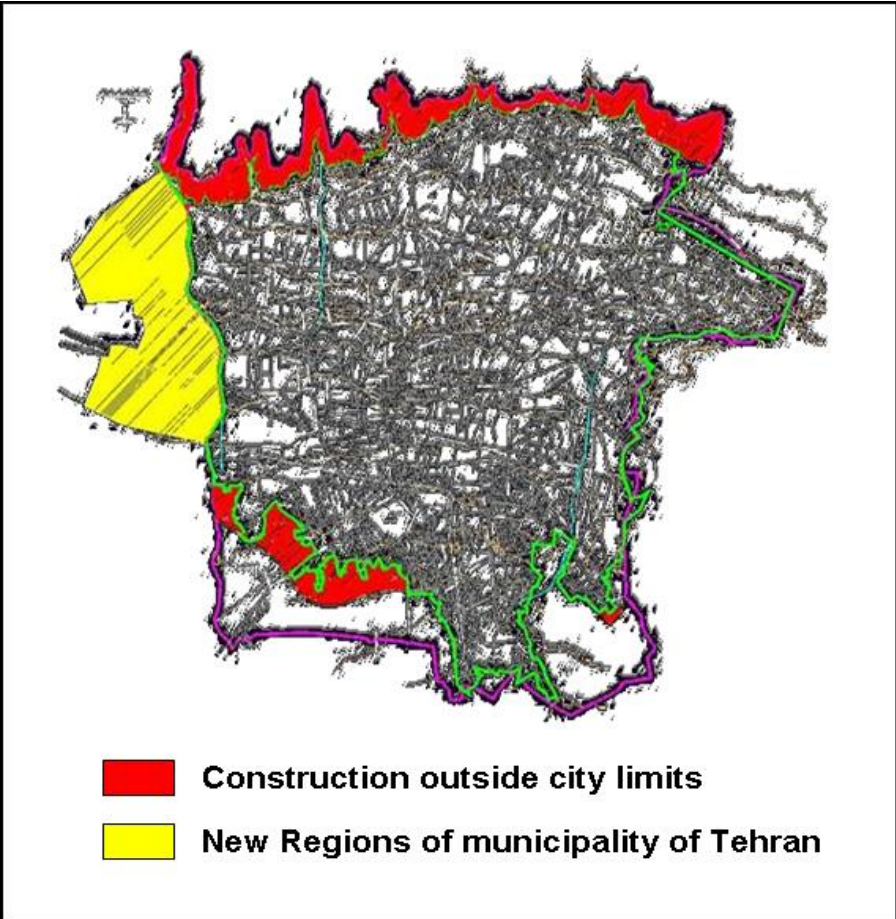

Figure 4: burgeoning population



Figure 5: more buildings at city limits



However, investors and property developers have apparently short-term visions with regards water supply and demand, precluding water management strategies from their developments and building construction building and thereby contributing to potential future water crises in Tehran. In order to be able to manage this challenge and to obtain more precise information, during 2003, the Tehran Province Water and Wastewater Company ordered aerial photographs to be taken of areas outside the city limits. The photographs were studied in detail and the information gained was transferred to maps. An analysis of these maps indicate that the total land being used outside the city limit is about 4000 hectares, and in the near future a population of close to one million will live there.

From an investment point of view, this will be very challenging, as estimates for the water and wastewater sector alone indicate that close to \$66 million USD is needed to meet demands.

Thus, in summary, the problems associated with rapid urban development on the city outskirts of Tehran, and which are challenges faced by other mega cities, include:

- unpredicted expenses and unplanned changes to existing long-term planning;
- destruction of natural heritage and especially the northern plains of Tehran;
- environmental abuse and its consequences and that impede sustainable development;
- increase in population in Tehran, and population extension;
- lack of developed infrastructure and investment impeding buildings and constructions.

## **IMPORTANT WATER AND WASTEWATER INDICATORS IN CITY OF TEHRAN**

Currently, although 98.5 percent of Tehran’s population have access to safe drinking water, only about one tenth of them (9 percent) have access to proper discharge of the wastewater system. In 2021, these numbers will be around 100 percent and 60 percent respectively.

Table 1: Important Water and Wastewater Indicators in Mega City of Tehran

Description	Unit	Current condition	Year 2021	Difference
Population having access to safe drinking water	Percentages	98.5	100	1.5
Total number of water subscribers	1000	880	1100	220
Volume of water needed	Million cubic meters	920	1400	480
Population having access to modern wastewater discharge system	Percentage	9	60	51

## **CURRENT SITUATION OF WATER SUPPLY IN TEHRAN**

In 1963 , the total water supply capacity of Tehran was around 300 million cubic meters. This supply volume was 30 percent more than demand. In 1993, supply and demand reached equilibrium, but from 1996, shortages surfaced. It is therefore predicated that by 2021 water demand will have reached 1400 million cubic meters per year, which means 480 million cubic meters of more water will be needed.

Figure 6: Chart of water consumption and demand

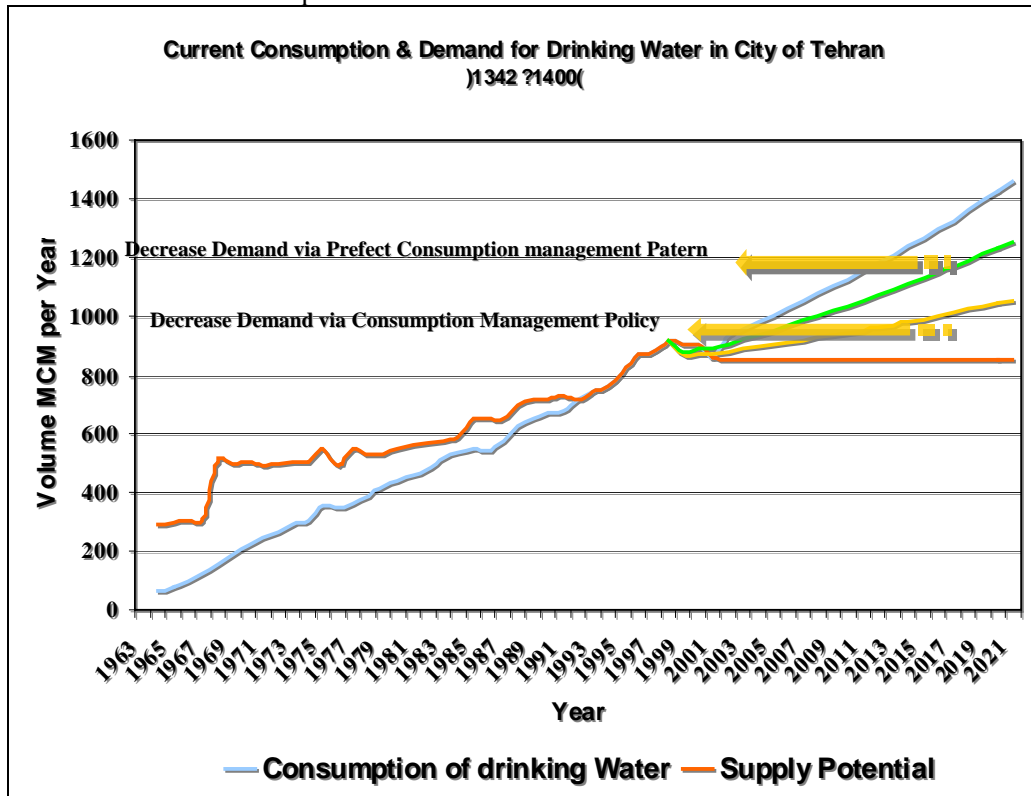

In order to balance this situation, activities should continue in two areas, namely water supply and consumption management. The following sections elucidate these ideas.

## ACTIVITIES RELATED TO WATER SUPPLY

### Construction of Talaghan and Mamloo dams:

A yield of 240 million cubic meters of water from these dams have been allocated to city of Tehran. These two dams are under construction and will become operational within next 3 years.

### Currently increasing water transfer from Lar dam:

The Lar Dam, water conveyance line and related tunnel together comprise one of main sources of water for greater Tehran. Currently about 70 to 100 million cubic meters are being supplied from this source. It is anticipated that an additional 60 more million cubic meters of new water will be able to be transferred if all plans considered for this project are executed.

### Constructing new conveyance lines and treatment plants

The fifth, sixth and seventh water treatment plants of Tehran, with a capacity of 20 cubic meters of water treatment per second and 65 Km of conveyance lines from Karaj and Mamloo to Tehran, will be constructed over a five year period.

Currently, the first phase of the fifth water treatment plant is underway, but whether it will take raw water from Lar dam is yet to be seen. The sixth water treatment plant, which will take water from

Karaj dam, and the seventh water treatment plant, which will take water from Mamloo dam, are also yet to be executed.

Figure 7: Chart of predicted water supply in 2021

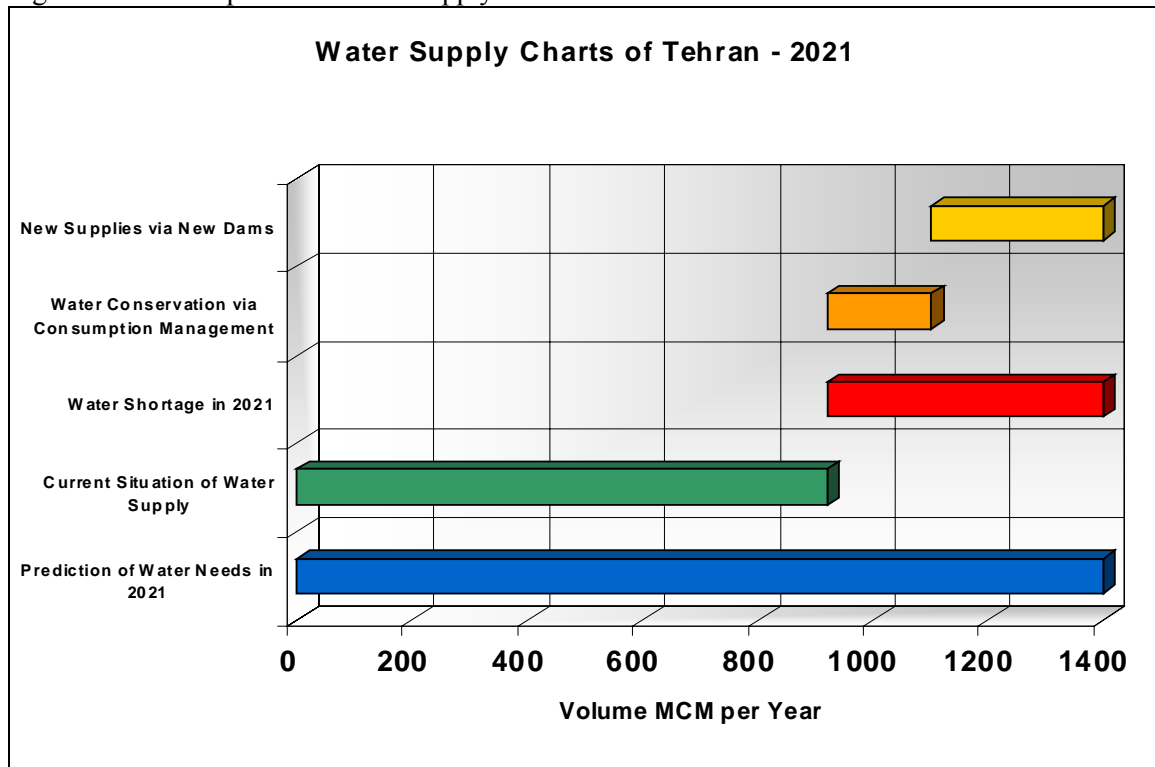

### Consumption management

The 180 million cubic meters of the total volume of extra water needed for year 2021 has to be provided via activities related to consumption management. Some of these activities include recording and analyzing consumption patterns, public relations activities to change public opinions about construction, changes to the fundamentals of national construction regulations, and assisting in the compilation and approval of standards for equipment used in the distribution and consumption of water.

Further, in considering the utilization of water consumption reduction devices, the following actions should be undertaken:

- separate use of high and low quality water;
- establishment of public education programs and research about social opinions;
- active participation in the production and distribution of radio and television programs about water conservation;
- establish active relations with the Ministry of Education and develop primary school education about water management;
- develop relations with NGO's active in water-related issues;
- stage water conservation exhibitions;
- establish water resource education centers;
- teach water conservation techniques to high school and college students;
- undertake local education: establish small groups to promote water conservation culture and hold face-to-face meetings with stakeholder groups such as housewives;
- improve water pressure zones in urban water distribution networks;



- conduct preventive maintenance and promote modern maintenance methods and work;
- conduct various studies and projects about water that is unaccounted for;
- install modern and precise water measuring equipment.

## **SOME EXPERIENCES RELATED TO TEHRAN'S 2001 WATER CRISIS**

After three consecutive years of drought, in 2001 Tehran faced a 29 percent reduction in water resources, whereby 270 Million m<sup>3</sup> was reduced from 91 m<sup>3</sup>/capita in a normal year (with deduction of UFW) to 64 m<sup>3</sup>/capita in 2001. The city was in an state of crisis, during which time several actions were taken and solutions utilized:

- a crisis control committee was established;
- a map room was organized;
- an information room was established;
- cooperation from various stakeholder organizations was sought: the office of the governor-general, ministry of energy, municipality of Tehran, etc;
- meetings were organized and held with employees of the Tehran Province Water and Wastewater Company and other affiliated companies to define and establish crisis control and water resource management objectives;
- weekly progress meetings helped monitor all activities related to crisis control, attended by senior managers and project directors.

In order to compensate for a shortage of 270 million cubic meters of water, it was decided 50 percent of this volume should be obtained from ground water via excavation of new deep wells, and the remaining 50 percent via consumption management. About 200 new deep wells were therefore excavated, causing enormous problems.

Further, many different alternatives and solutions related to consumption management were experienced, such as:

- reduction of water pressure in the distribution network;
- installation of water consumption reducing devices;
- shut-down of water in the network during night time;
- disconnection of the water service of subscribers who don't adhere to prescribed consumption;
- disconnection of water services based an pre-announced schedule in some limited areas;
- periodical shut-down of water services during the day in some parts of the city for six months.

The periodical shut-down of water services had some positive effects in reducing consumption, as this schedule was executed for six days a week from 9 am to 9 pm, excluding Friday (considered the 'weekend' in Iran). Gradually, in some parts of town located at higher altitudes, the length of shut-down time of water service was reduced to ten hours a day. One of the main problems in relation to this process was air ventilation in the network, for which finding a solution was extremely cumbersome. In general, there was widespread public dissatisfaction with water shut-downs, with citizen complaints and objections made via newspaper, calls to television and radio stations, etc. It is acknowledged that such periodical closure of water services is a very dangerous alternative, and should only be considered or implemented as a last resort.

To counter these negative impacts of water shut-downs, several other solutions were also used, including:

- increased water supply capacities;
- improved quality control systems;
- improved water conveyance and pumping capabilities;
- reconstruction, leakage control and alteration of sensitive valves in the distribution network;

- re-checking of water volumes entering and exiting from water reservoirs;
- establishment of water network zones;
- re-construction of water service lines and extensions;
- separation of water used for plants/greenery;
- disconnection of illegal connections;
- reduction of UFW (unaccounted for water);
- changes to water meters and use of new pipes;
- expediting and shortening the time period of responding to accidents;
- installation of consumption reduction devices;
- changes to national construction regulations;
- cooperation in writing technical standards for various water valves;
- changes to water tariffs and fines for those who avoid payment;
- increased attention to consumption patterns and utilization of long-term consumption management techniques.

Figures 8 (a) and 8 (b): workers in wastewater plant



## **SUGGESTIONS/ PROPOSALS FOR WATER MANAGEMENT IN MEGACITIES**

Further to these ‘lessons learnt’ from the water crisis situation in Tehran, it is useful to consider general suggestions and points of improvement to better manage water in mega cities, such as, for example:

- prioritising water consumption reduction management, including planning and investment;
- creating and developing water supply installations, related to distribution and control of water quality;
- defining consumption patterns and executing consumption management strategies;
- promoting the improvement of operational water resource technologies, and utilizing modern quality control technologies and quantity control devices;
- executing public relations and educational programs;
- collecting and treating urban wastewater by undertaking specific projects in this regard;
- securing water resource management networks against natural disasters;
- implementing and using a Graphical Information System;
- creating the modern urban water telemetry and tele-control system;
- increasing coordination amongst different types of organizations responsible for urban challenges that confront mega cities, such as water resource management.

## **CONCLUSION**

Focusing on water equally entails focusing generally on issues related to development and culture. In times of water shortages and increases in water demand, this in turn can implicate hostilities as citizens and organizations fight over scarce and finite resources. Public determination and the right planning can act as a catalyst for more effective water management, improved urban development and implementation of effective practices for the vitality, sustainability and social welfare of mega cities. By examining case studies, sharing experiences and following best practice examples, organizations around the world can benefit from those assessments made by their peers. In the case of Tehran’s water crisis and related experience, it is hoped that this example will help the axis of cooperation among cities and countries so as to avoid duplication of negative impacts and facilitate replication of positive solutions to managing water in a mega cities.

# TRAINING AND CAPACITY BUILDING IN WATER AND WATER TECHNOLOGY IN EGYPT

Mohamed B. Abdel Ghany, Coordinator of Regional Program, RCTWS, Egypt;

Dalal S. Alnaggar, Director, Regional Center for Training and Water Studies (RCTWS);

Email: dalnagar@trainingcentre-eg.com

## ABSTRACT

The sustainable use of water is a priority issue for water-scarce regions and for its usage for agricultural purposes in particular. Imbalances between availability and demand, degradation of surface and groundwater quality, inter-sectorial competition and inter-regional and international conflicts, all bring water issues to the foreground. In fact, developments in controlling and diverting surface waters, exploring groundwater, and in using the resources for a variety of purposes have been undertaken, without sufficient care being given to conserving the natural resource, avoiding wastes and misuse, and preserving the quality of the resource.

The Ministry of Water Resources and Irrigation (MWRI), is one of the oldest established ministries in Egypt that has mandatory responsibility to dominate all water resources, and to protect, develop, control and allocate them for different uses. The MWRI bears the responsibility of developing strategies and implementing policies and plans for balancing water supplies versus water demands in Egypt. Sustainable and efficient training for MWRI staff is an important milestone for the achievement of successful policies and plans.

To acknowledge the importance of water resource management, the Government of Egypt and UNESCO signed an agreement in December 2001 to establish the Regional Center for Training and Water Studies in Arid and Semi-Arid Zones (RCTWS). The Center commenced in January 2002, and today it functions as an international educational, training and development institution, for the Arab and Nile Basin countries, as well as for arid and semi-arid regions. It hosts three main programs: the national training program, the regional training program and the applied training program for Nile Basin countries. This paper discusses all the training activities and achievements of the RCTWS in the field of capacity building and technology transfer in all fields of water resource management.

## INTRODUCTION

In the beginning of this new century, the world faces many challenges. An increase of nearly 2.6 billion people in the world within the first quarter of the century, with its implications for economic development, basic health and food production, seriously threatens the already stressed and fragile ecosystem of the planet.

However, the current rate of increases in water withdrawal is twice the rate of the growth in population. Thus, water - its use, management and scarcity - has emerged as one of the most vital issues for society today, and is assuming increasing importance on the global agenda. Other issues, such as public health, poverty, climate change, biodiversity, deforestation, and desertification, are also closely linked to water issues.

The last few years have seen increasing awareness of and interest in the concept of integrated water resources management (IWRM) as a means to address water issues and conflicts at all levels-whether at the global, national, river basin, or community.

Through a number of parallel initiatives, the Egyptian Ministry of Water Resources and Irrigation (MWRI) is currently building up water education, training and research capacities in the domain of integrated water resources management (IWRM). The MWRI National Training Centre was established in 1982 in order to achieve these objectives. In 1985, the Centre expanded its scope of services through the irrigation management system project. Initially structured as a part of a water research centre, since 1991 it has reported directly to the Minister of Water Resources and Irrigation.

The objective of the Centre is to function as a regional hub or centre of excellence in the generation, transfer and exchange of knowledge in water resources management, water engineering and water-related sciences, particularly for the Nile, Arab and Mediterranean regions. The Centre conducts quality training and education in relevant subjects and promotes scientific studies, stimulates and coordinates applied research and enhances awareness creation in this field. The Centre aims to play a pivotal role in stimulating connectivity between knowledge institutions by establishing regional networks for scientific co-operation, knowledge management and information exchange. The Centre will continue to advocate increased educational capacity throughout the region and to use capacity building as a means of levelling the playing field for underprivileged nations.

### Water policy in Egypt

The River Nile, the longest river in the world, is the main source of irrigation in Egypt (see Figure 1 below). Historically, Egypt's rich agricultural land, with the exception of a few scattered oases in the desert, has consisted of the 1,200 km strip of the Nile River Valley and the Nile Delta. The increase in population, demonstrated in Figure 2 (also below), has led to higher crop intensities and horizontal expansion. The annual per capita share of the country's water resources is approximately 875 m<sup>3</sup>, of which 84 percent is crop water demand, with the consumptive use being nearly 68 percent.

Figure 1: Map of Egypt and The Nile River

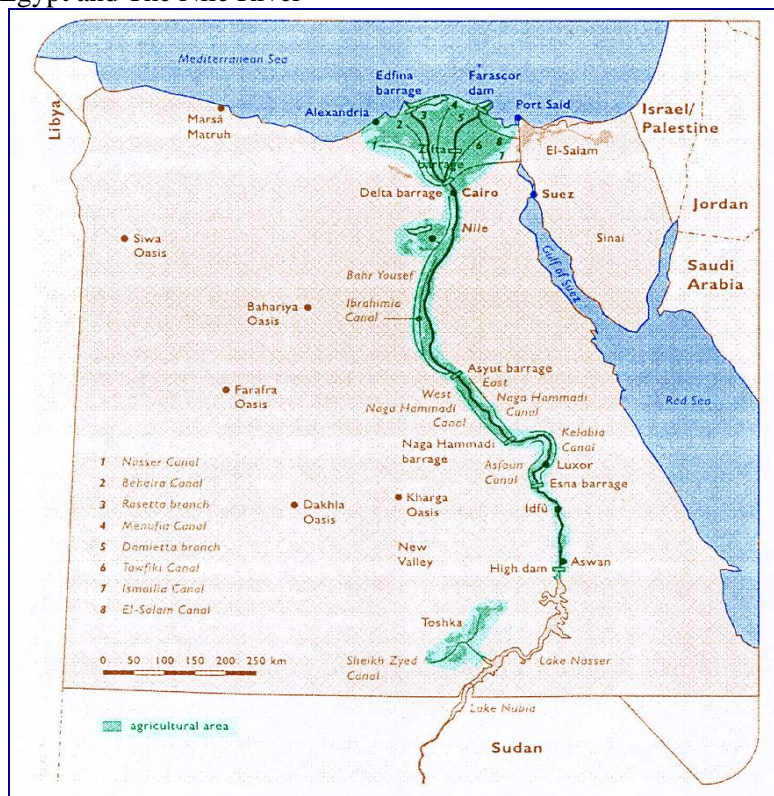
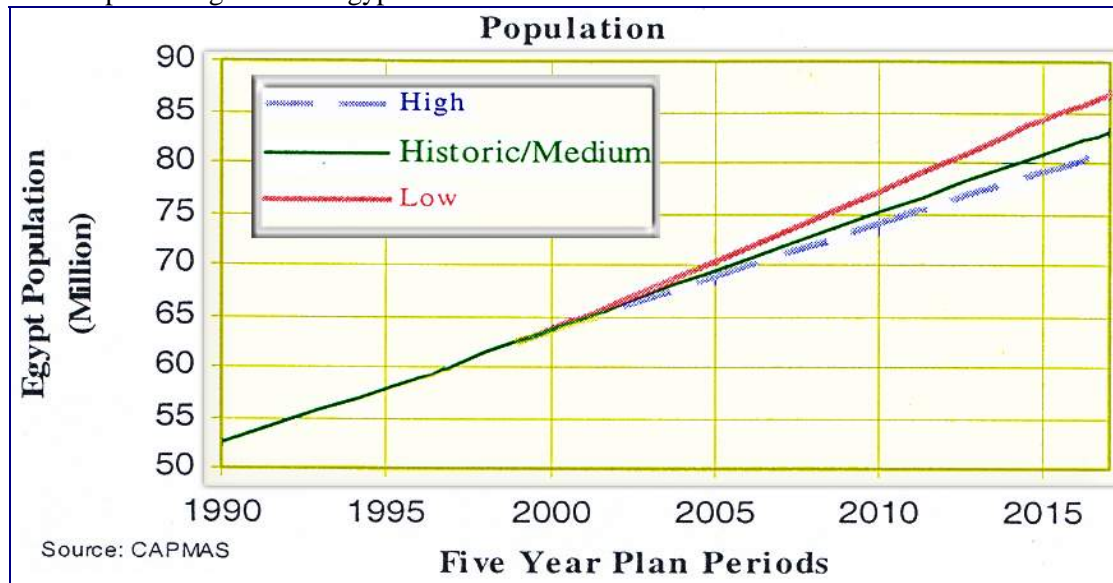

Figure 2: Population growth in Egypt over time



The national water balance assessment prepared for Egypt indicated that there was an overall water deficit of approximately 8 billion m<sup>3</sup>. This shortage was compensated for by increasing the efficiency of available water resource utilization through reuse of drainage water and the use of groundwater (Attia and Ezzat, 1999). Egypt has no effective rainfall, except in a narrow band along the northern coastal areas where some rain-fed agriculture is practiced. Groundwater underlying the Nile Valley and the Delta entirely depends on both deep percolation and seepage of irrigation water diverted from the Nile. Some limited renewable and non-renewable groundwater resources occur in the Nubian sandstone of the western desert (Sahara) and in Sinai. Extending and developing new land by the water made available through more effective use of and supply from the Nile Basin is the continuous role of MWRI.

Thus, looking to the future, various policies for increasing the usable supply of water or improving the efficiency of its utilization have been identified. These include Upper Nile development projects, improved management of the irrigation system, reduced flows to the sea by storage in northern lakes, increased exploitation of groundwater and expansion of drainage water reuse.

## WATER SUPPLY

The MWRI has always focused on developing old and new water supplies to satisfy the ever-increasing demands. Some of these initiatives are described below.

### High Aswan Dam

Surface water resources are limited to Egypt's share of the Nile River, together with minor amounts of rainfall and flash floods. The average annual natural flow of the Nile estimated at Aswan is about 84 billion m<sup>3</sup>, of which 55.5 billion m<sup>3</sup> is Egypt's share, 18.5 billion m<sup>3</sup> is Sudan's share, and the remainder is left to evaporate. The High Aswan Dam provides storage to guarantee regulated water supplies, as demonstrated in Figure 3 (below).

## Upper Nile Projects

The 1959 Nile Waters Agreement signed by Egypt and Sudan stipulates that joint projects are to be executed to increase the yield of the river. The expected yield of these projects shall be divided equally between the two. Three projects in particular have been scheduled to be implemented in the near future: the Jonglie Canal, Bahr El-Ghazal development and River Sobat-Machar Marshes. These Upper Nile water development projects will add approximately 18 billion m<sup>3</sup>/yr to the present flow of the Nile, to be equally divided between the two countries. This water is procured by minimizing the losses in southern Sudan, and does not affect the supply to the other eight Nile Basin countries. In reality, however, only the Jonglie Canal Phase I project is expected to be completed before 2025. Phase I is expected to increase the share of water for Egypt by 2 billion m<sup>3</sup>/yr.

## Groundwater

Groundwater exists in the Nile Valley and Delta, the Western Desert, and Sinai. The largest groundwater deposit is the giant Nubian sandstone aquifer underneath the eastern part of the African Sahara, and is shared between Egypt and four other countries. The top of the aquifer varies from near-ground level to over 4,000m below. It contains over 150,000 billion m<sup>3</sup> of non-renewable water in total, with a salinity mostly less than 1,000 parts per million (ppm). Much smaller aquifers, with relatively high salinity levels, exist in Moghra, Sinai, and along the coast.

The aquifer underlying the Nile Valley and Delta has a total capacity of 500 billion m<sup>3</sup>, with salinity levels at around 800 ppm. The current abstraction level is about 4.4 billion m<sup>3</sup> /yr from the Nile aquifer. Groundwater in the Nile aquifer cannot be considered a separate source of water. The aquifer is renewable only by seepage losses from the Nile, irrigation canals and drains; and percolation losses from irrigated lands. This aquifer should be seen as a reservoir underlying the Nile River, with about 7.5 billion m<sup>3</sup>/yr rechargeable live storage. The same applies to the other aquifers existing on the fringes of the Nile Valley and Delta, where surface water is the main source of irrigation (Moghra in the Western Delta, and Plio-Pleistocene in the valley). In these aquifers, the ground-water potential depends greatly on subsurface drainage. The main water resources in Egypt are shown in Table 1 below.

Table 1 Water Resources in Egypt

Types of Water Resources	Water quantity during different years		
	1990	2000	2025
Nile water	55.5	55.5	55.5
Reuse of agriculture Drainage water	4.6	7	7
Deep groundwater	0.5	2.5	3.8
Treated waste water	0.2	1.5	1.5
Winter closure water	-----	1.0	1.5
Water harvesting (rains etc...)	-----	-----	1.5
Reducing Evaporation losses from High Aswan Dam	-----	-----	2.5
Sea water desalination	-----	-----	1.0
Total	60.8	67.5	74.3

## WATER DEMANDS

Irrigation agriculture consumes the bulk of the available water supplies. Despite losses of agricultural land to urbanization, the cropped area statistics indicate a very modest increase during the last decade due to an increase in cropping intensity, complying with the national plan to achieve food security (Alnaggar, 2003). The distribution of crop areas has not changed significantly during the last decade. Based on the cropping pattern and on the crop water duties, present withdrawals for irrigation water can be calculated. The main Regional Irrigation Demands (including the recently reclaimed lands), are shown below in Table 2.

Table 2: Regional Irrigation Deman

Region	Area (km <sup>2</sup> )	Annual water use (billion m <sup>3</sup> )
Eastern Delta	7.77	13.35
Middle Delta	6.93	11.60
Western Delta	6.30	10.60
Middle Egypt	5.88	9.90
Upper Egypt	5.04	8.40
Total	31.93	53.85

Figure 3: Nile Valley and Delta Water System

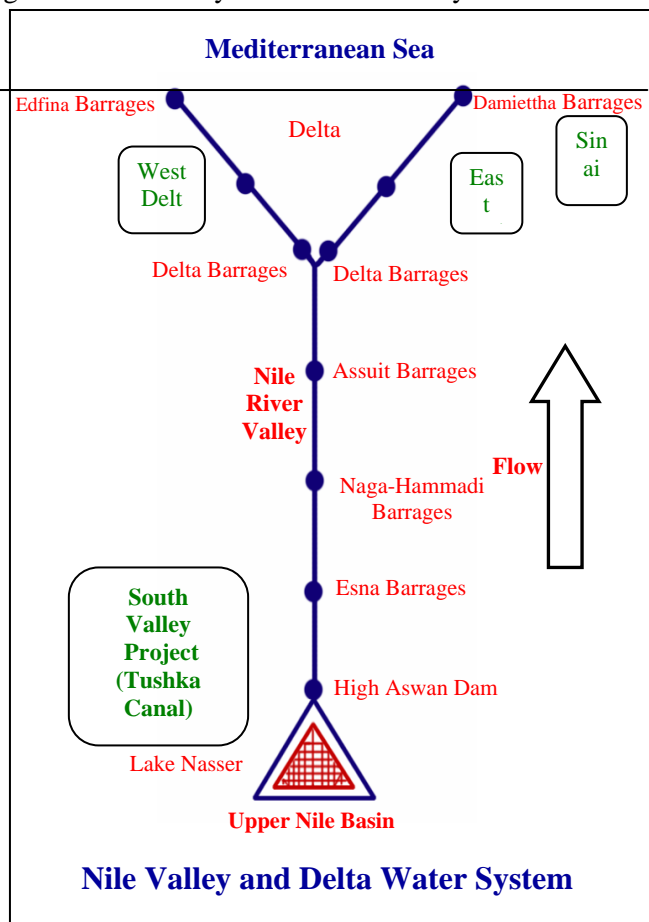
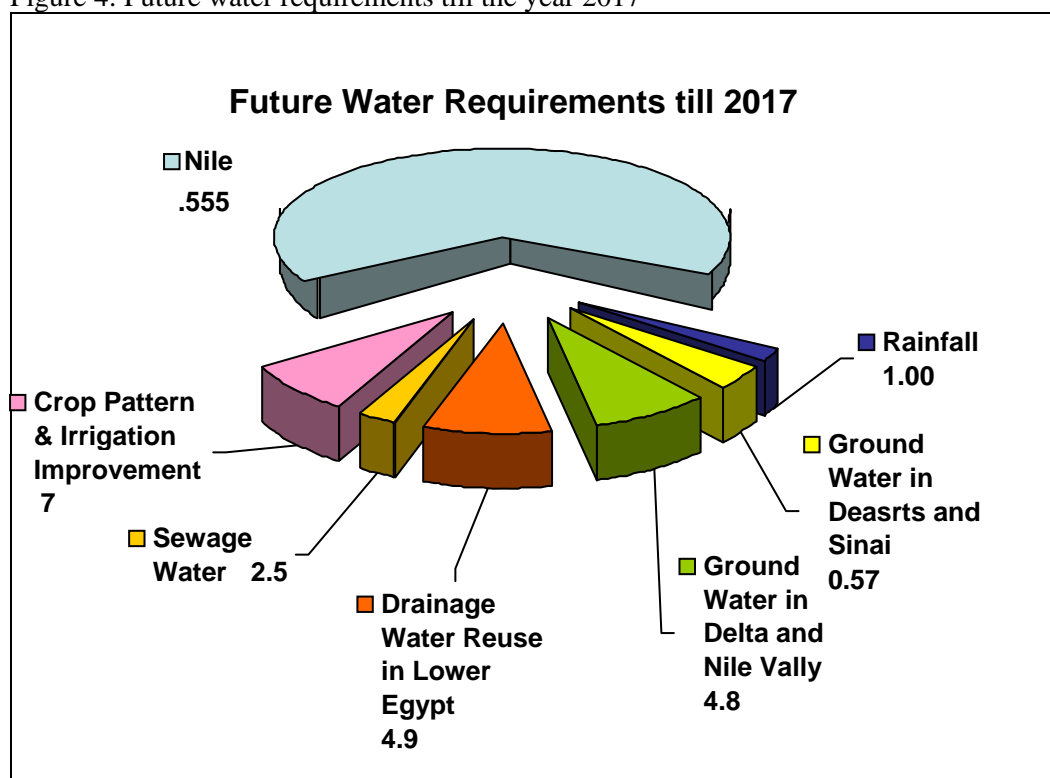



Figure 4: Future water requirements till the year 2017



Agriculture consumes water by evaporation and evapotranspiration. Evaporation losses are conveyance losses from the canals, estimated at about 2.0 billion m<sup>3</sup> /yr for the whole country. Evapotranspiration is dependent on the cropping pattern used. Cropping patterns are a crucial factor in water resources management, especially under the free-market policy. The prediction of future water requirements depends upon the best estimation of cropping patterns, and Figure 4 (above) illustrates the future water requirements for the year 2017.

The combined effect of rapid population growth and an increase in living standards has led to an increase in the demand for food. The Ministry of Water Resources and Irrigation (MWRI), in Collaboration with the Ministry of Agriculture and Land Reclamation, has planned an ambitious program to reclaim approximately 7,170 km<sup>2</sup> of land by 2010.

Some of the reclaimed areas will be irrigated by mixing the Nile Water with drainage water, such as that of the El-Salam Canal, which will cross the Suez Canal to reclaim 2605 km<sup>2</sup> in Northern Sinai. Others rely on the conjunctive use of deep groundwater with Nile water. In addition to this program, there are sub-programs to reclaim 126,000 ha using groundwater in the western Desert and 84,000 ha using sewage water after treatment.

### **Municipal and industrial water demands**

Estimation of the municipal water use depends on population growth rates, the consumption in litre/ Capita/day, and distribution system losses expressed as conveyance efficiency Estimation of Municipal Water use.

## Navigation and hydropower water use

From February to September, water released from the High Aswan Dam (HAD) for irrigation, municipal, and industrial purposes is sufficient to maintain the required navigational draft in the Nile, as per Table 3.

## Outflows to sea

Water enters the system at the High Aswan Dam and flows to the sea as freshwater through the Rosetta and Damietta branches, and as drainage water through the main drains. Present outflows of drainage water into the sea and terminal lakes through the drainage network are about 12.0 billion m<sup>3</sup>/yr.

To conserve the Nile freshwater that is annually lost to sea, several proposals have been considered for inclusion into the annual budget, including for example:

- storage in the old Aswan Dam.
- off-channel storage in depressions such as Wadi Elnatron.
- artificial ground-water recharge.
- increased winter irrigation in reclaimed desert areas.
- storage in the coastal lakes (Edku, Maryut, Burollus, and Manzala).
- staggering or eliminating the winter closure period.

## DISTRIBUTION SYSTEM EFFICIENCY

Network conveyance efficiency can be expressed by calculating the system diversion losses starting at the source of feeding (intakes, regulators, water purification plants, pumping stations, and elevated tanks), through the distribution system, and finishing with end users.

The diversion efficiency of the agricultural system is 60 to 70 percent, while it is 50 to 60 percent for the municipal and industrial sectors currently. Some 8.9 billion m<sup>3</sup> of the return flow is being reused, and with system improvement, there is the potential for this to reach 17.2 billion m<sup>3</sup> in the future.

Although the seepage from the network flows to the groundwater, where it can be pumped and used again, the difficulty in estimating the portion of water losses that are later reused has resulted in accounting for these quantities as wasted. Distribution losses in the municipal sector are evaluated as 60 percent in rural areas and 40 percent in urban regions. Efforts are being made to reduce the level of system losses to acceptable limits, including, for example, rehabilitation of the conveyance pipe network to eliminate leakage, a variable domestic water rate system with higher rates for higher consumption as an incentive for people to economize, and provision of domestic water-saving sanitary equipment.

Table 3: Water Uses

Water uses	Water Requirements (B M <sup>3</sup> ) Throughout years		
	1990	2000	2025
Agriculture	(1) 49.7	(2) 59.9	(3) 69.9
Domestic uses	3.1	3.1	5.0
Industry	4.6	6.1	7.0
Navigation	3.0	0.3	----
Total	60.4	69.4	81.9

Total agriculture land, year 1990 = 7.4 million feddan; Year 2000 = 7.4+1.2=8.6 million feddan

Total planned agriculture land, year 2025= 8.6+ 1.7= 10.3 million feddan.

## **POTENTIAL OF TREATED WASTEWATER REUSE IN EGYPT**

### **Wastewater**

Studies in many countries have shown that crop yield may increase when irrigated by primary and secondary treated wastewater effluent if such a wastewater treatment process is properly managed.

With population growth and continuing urbanization, the volume of wastewater continues to grow and its disposal becomes a serious problem. Reclaiming and reusing municipal wastewater for irrigation is an easy and useful means of disposal and an attractive and innovative alternative to meet increasing water demand.

### **Treatment and reuse of sewage effluent**

The concept of reusing sewage after primary treatment for agriculture has been practiced since 1925 in the eastern desert area of El-Gabal Al-Asfar outside Cairo. An area of 4,000 feddan of desert lands was cultivated and is successfully producing citrus fruit, date palms and pecan nuts. However, interest in the use of treated wastewater has accelerated significantly since 1980 for the following reasons (Riad, 2000):

- The population has increased significantly, resulting in more and more wastewater being produced in urban and rural areas;
- The centralized sewage treatment works produce large quantities of treated wastewater, making their use for agriculture a viable alternative;
- Wastewater is considered as a nutrient-rich source that can be used for agricultural production and thus help alleviate food shortage, with reduced use of fertilizers;
- Treated wastewater can be safely used for public parks and recreation centers, landscape areas and golf courses. It could also be used for industrial purposes and groundwater recharge; and
- Wastewater can help in controlling dust storms and desertification through irrigation and fertilizing tree belts. It also controls environmental degradation caused by the demand for fuel wood.

However, reusing treated effluent for widespread irrigation is sometimes limited by certain economic, technical and public health uncertainties about the impacts of such use. Also, wastewater reuse can create major problems if the system is not properly planned and maintained. In assessing these hazards, various pathways for the transport of pollutants and, therefore, the possible health risks and the potential environmental damages have to be studied. Health considerations focus on the pathogenic organisms that present in the effluent and the build-up of toxic materials in the soil and subsequently within plant and animal tissues, which might eventually reach the human food chain. Environmental risks include nitrates and toxic soluble chemicals leaching into groundwater, and dissolved substances that adversely affect the soil and crop growth, development and yield.

There are four major measures that can be adopted for health and environmental protection in wastewater reuse for irrigation: wastewater treatment, crop restriction, wastewater application control and human exposure control (Arar, 1998). Wastewater reuse is further explored in the following section.

### **Research on wastewater reuse**

Several studies on wastewater use for agriculture and its impact on the soil and the environment are being conducted at the Ministry of Agriculture and Land Reclamation (MALR).

The research examines the following topics:

- proper use of wastewater and sludge;
- appropriate irrigation methods for reusing wastewater;
- changes in the chemical and physical properties of the soil;
- potential heavy metal toxicity to crops irrigated with wastewater; and
- best soil-water management practice in terms of the amount and frequency of water application.

In the last five years, active pilot forest projects irrigated with wastewater were initiated by MALR in nine different locations in Egypt (Riad, 2000). The areas ranged from 50 feddan as in Abu Rawash to 1000 feddan as in Luxor. The results show that the tree varieties selected in the pilot sites have excellent economic value in terms of timber production. Also, inter-cropping other crops with trees such as ornamental plants and cut flowers has proven to be fully possible, thus helping to obtain faster economic returns.

### **Present and planned reuse of treated sewage effluent**

At present, domestic and municipal use of water is 4.5 bcm/yr. The current per capita per day wastewater generation rate in different parts of the country is 190 liters in urban, 77 liters in rural and 135 liters in the Delta in average. The sewage flow in the Delta is expected to increase by 1.5 times in twenty years as shown in Table 4 below.

Table 4. Projected wastewater flow in Cairo and the Delta (Abdel-Gawad 2001)

Year	Population	Sewage flow
	Delta + Cairo (million)	Total (c/d)
Current	44.619	6.016
Urban	22.913	4.350
Rural	21.706	1.666
Year 2002	49.407	6.662
Urban	25.372	4.817
Rural	24.035	1.845
Year 2007	54.709	7.376
Urban	28.094	5.334
Rural	26.615	2.043
Year 2012	60.580	8.168
Urban	31.109	5.906
Rural	29.471	2.262
Year 2017	67.081	9.045
Urban	34.448	6.540
Rural	32.633	2.505

The total production of potable water treatment plants is 6.6 bcm/yr and for sewage treatment plants it is about 3 bcm/yr. The distribution of existing sewage treatment plants is mainly in the capital and major cities as shown in Table 5 below. It has been estimated that the total quantity of reused treated wastewater for irrigation was 0.7 bcm/yr in 2000, of which 0.26 bcm was secondary treated and 0.44 bcm was primary treated.

Table 5. Distribution of existing sewage treatment plants capacities (NOPWASD 2000) (Abdel-Gawad 2001)

Region	Flow 10 <sup>3</sup> m <sup>3</sup> /d
Greater Cairo	3280
Alexandria	1000
Suez canal	430
Delta	1137
Middle Egypt	170
Upper Egypt	321
Sinai, Matrouh, New Valley, new cities	1945
Total	8283 (3 bcm/yr)

In the planning for horizontal development by the year 2017, an amount of 2.5 bcm/yr of treated wastewater from Cairo and Alexandria is required to irrigate 280,000 feddan located in South Helwan (40,000 feddan), Zenin and Abu Rawash (70,000 feddan), Berka and Gabal El Asfar (100,000 feddan) and El-Hammam (70,000 feddan), at a total cost of more than 1.41 billion LE to cultivate mainly timber trees and industrial crops (cotton, flax, jut, etc.). Wastewater from domestic sources contains about 97 percent water and 3 percent organic and non-organic solids. These solids are rich in some of the nutrients necessary for plant growth such as nitrogen, phosphorus, potassium, boron and zinc. The organic content of sewage effluent improves the physical and chemical properties of sandy soils by increasing their water-retention capacity.

## POLLUTION PREVENTION

Pollution prevention and treatment of wastewater seems to be the only real solution for the present problems in water quality. Pollution prevention in Egypt can be promoted through:

- changing of industrial production process and converting to clean technology
- treatment of wastes at the source
- wastewater collection and treatment through central treatment facilities and rehabilitation of the existing plants
- ban on the use of specific agricultural chemicals (pesticides, herbicides, etc.)
- prevention of pollution production through public awareness programs on the national level
- law enforcement with periodic adjustments over time to reflect changing realities.

## NATIONAL POLLUTION CONTROL MEASURES

The MWRI faces multidimensional challenges in sustaining the current levels of water reuse and promoting more drainage water reuse over the next decades. A major challenge is therefore to develop pollution control plans that are cost effective, compatible with the state of social and economic development and provide achievable benefits.

The Government of Egypt has promoted concerted action in order to protect the water resources from over consumption, pollution and rising threats from limited water resources and increased demands. These actions are being implemented and are expected to have, in a very near future, a positive impact on water resources and Egypt's development. The elements of these pollution control measures are to (DRI, 1995; DRI, 1997 and Abdel- Gawad 1998):

- declare a firm policy against the disposal of untreated waste in the water bodies
- implement the existing environmental and water quality laws in phases to ensure their practicability in the light of potential funds and available technology and experience
- encourage innovative low-cost domestic wastewater treatment facilities in rural areas

- promote public awareness programs on the national level to support the prevention of water pollution
- remove the government's subsidies on fertilizers and pesticides and ban the use of some specific agricultural chemicals (herbicides and pesticides)
- abate industrial pollution at its source by means of in-plant measures such as closed loop processes and increased water recycling
- introduce the environmental impact assessment (EIA) as a new instrument for pollution abatement
- encourage the involvement of farmers and water users associations (WUA) in drainage operation and maintenance.

## **CAPACITY BUILDING EDUCATION, TRAINING, AND AWARENESS**

The Ministry of Water Resources and Irrigation emphasizes the importance of capacity building, education, and training. In recent decades, around 170 professionals from the National Water Research Center have completed their Masters and Doctorates (PhD) from local and foreign universities in various disciplines associated with water resources management, irrigation and drainage. Further, specialists can be involved in the RCTWS, which is elaborated on in the following section.

### **Regional Center for Training and Water Studies (RCTWS)**

The main responsibility of the RCTWS is to organize and strengthen the regional water studies network and to develop an efficient program for advisory services; information transfer activities and applied research findings. The mission of the center is to offer specialized training programs, workshops, and applied studies focused on integrated water resources management. The program will be of interest to managers, engineers, technicians, and administrative staff working in the field in Egypt as well as Arab, African and other regional countries. The Center carries out its mission and functions in close relation to water-related programs of UNESCO, and depends upon the extent to which international and regional support can be mobilized.

The RCTWS hosts three main programs: 1) the national training program; 2) the regional training program for arid and semi arid regions; and 3) the applied training project program for Nile Basin countries. These are explained in more detail below:

#### **The national level: national training program**

The national program has operated since 1994, with the start of the Training Center (TC) of the Ministry of Water Resources and Irrigation (MWRI). The Center has the capacity to train about 3000 participants every year. The plan of the RCTWS was to define the training programs related to water management. Such programs were studied and discussed during regional and international conferences, seminars, and workshops. Most of the findings indicated that efforts are directed towards two objectives: 1) improving the scientific base of integrated water resources management through appropriate training; and 2) improving intersectoral and intergovernmental cooperation.

The main program comprises the following types of activities, which are offered regularly at different levels, and can be tailored to different training needs or into training modules:

- scientific and technical programs for engineers and technicians
- management, administration and financial courses
- computer and English language courses
- field studies, practical, and laboratory training programs
- workshops, conferences, and other scientific activities.

## **The regional level: regional training program for arid and semi arid regions**

This program was initiated recently under the auspices of UNESCO, with a main responsibility to organize and strengthen the regional water studies network and to develop an efficient program for advisory services, information transfer activities and applied research findings.

The mission of the project is to offer specialized training programs, workshops, and applied studies focused on integrated water resources management. The program will concern related managers, professional engineers, technicians, and administrative staff, both in Egypt as well as Arab, African and all Regional countries. The Center will carry out its objective and functions in close coordination with water-related programs of the UNESCO and will depend upon the extent to which international and regional support can be mobilized.

### **Regional training need assessment (TNA)**

Training needs assessment (TNA) is one the most important steps in designing human resources development (HRD) initiatives within the region. The TNA mission showed that the most important topics to be considered for training are:

- water resources assessment management issues and hydro-informatics
- surface and groundwater modeling
- decision support systems
- data acquisition and analysis
- total quality management
- geographical information system (GIS) and remote sensing (RS) in water resource management
- economic aspects of water resources projects.

### **Priority of training needs**

From the above topics and study it is clear that the first priority is to start with certain types of module courses, to be targeted at senior staff, middle managers, engineers (from different disciplines like agriculture, civil, water resources), agronomists and soil scientists who work in the field of water management.

The second priority is to provide workshops to improve the effectiveness of groups from the region as a whole. To this end the responsibilities of the RCTWS include: organizing and strengthening the regional water studies network; developing an efficient program for advisory services; establishing a regional library rich in its collection, updating the Media Unit for water studies; modernizing the technical laboratories; and updating and improving curriculum development for training programs (scientific, technical, practical).

The Regional Training Program includes several regionally-based modules such as: water resource assessment and hydro-informatics; integrated water resources management; on-farm water management; environmental management of water resources; and the applied training program. The Nile Basin Countries took a historic step in establishing the Nile Basin wide cooperation through the establishment of the Nile Basin initiatives (NBI). The (NBI) includes several programs, amongst which is the applied training project. Each country from ten Nile Basin countries has a focal point, while Egypt holds PMU.

The third priority of the RCTWS is to provide, specialized courses to be tailored according to the training needs. Training is further discussed in the following section.

## Nile Basin applied training program

The applied training project contributes to strengthening the capacity of water professionals in the Nile Basin, including women, to adopt integrated water resources management (IWRM) practices. The IWRM concepts and practices to be promoted through the project include concerns of efficiency, equity, and participatory management of water resources. In addition, the central feature of the project is the facilitation of interchange of expertise and experience among Basin institutions and professionals, to strengthen the Nile water fraternity and thus stimulate dialogue among riparians, so that they can eventually undertake collaborative enterprises for mutually beneficial purposes.

The four main project components include: establishing the Nile Net; developing human resources; building institutional capacity; and promoting basin exchange. The Project Management Unit (PMU) will assist and manage these components by training managers, senior executives and decision makers working in the field of water management.

## RCTWS participation in international networks:

The RCTWS in Egypt is part of and participates in many international networks that are focused on integrated water resources management. The RCTWS aims to share its visions about water problems and capacity building for scientists, senior engineers and technicians at national, regional and international levels. The following are the networks in which the RCTWS has participated (see Figure 5 below): La-Wet Net, Nile Net, Aware Net, Cap Net, G DNWRM Net, IHP, and DRCAN Net.

Figure 5: RCTWS Active Share and Participation in International Networks

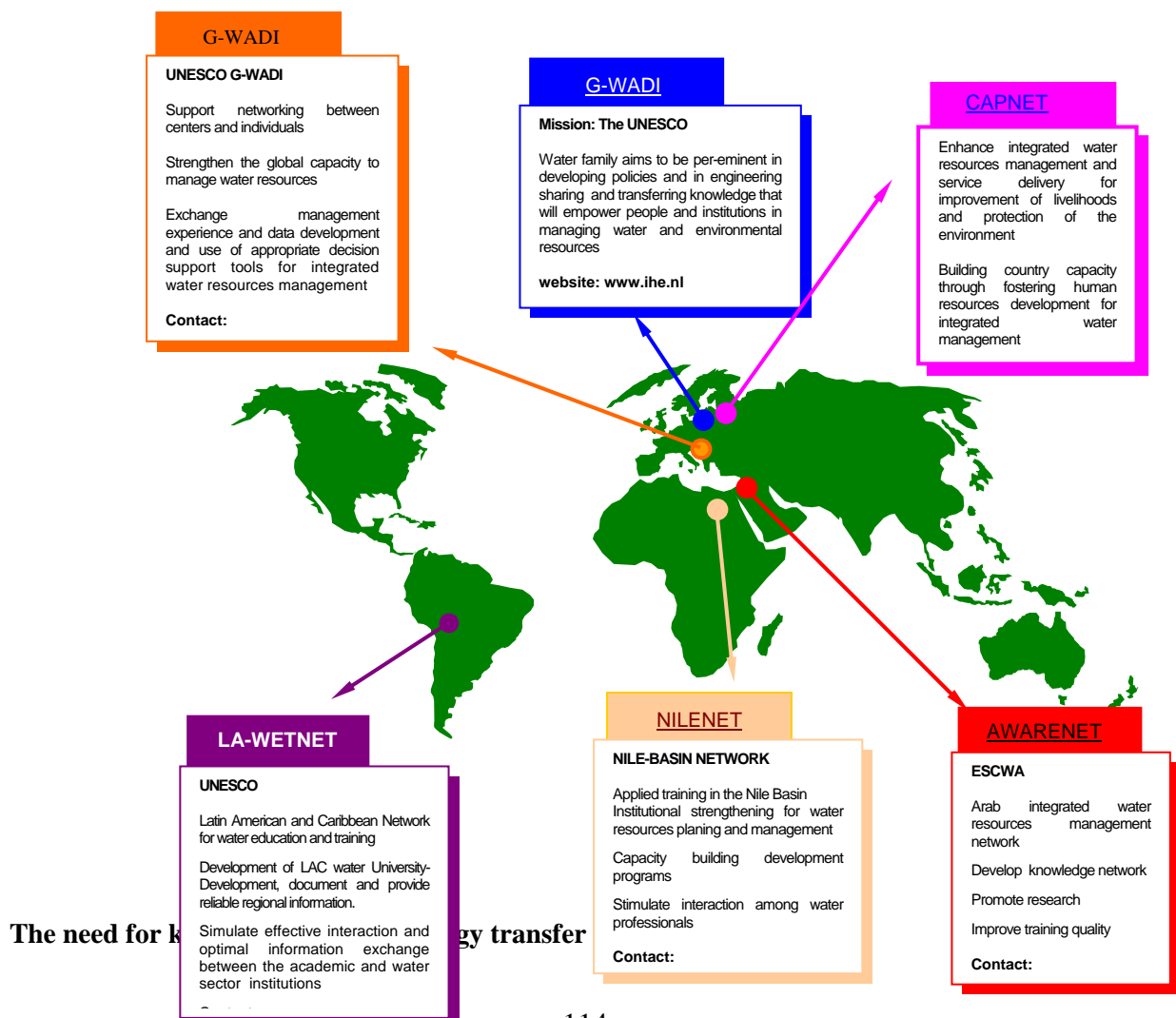



At present, data and information systems related to water resources in terms of quantity, quality, accessibility and use are generally inadequate for Nile Basin countries. Some countries have, to some extent, established data and information systems related to climate, rainfall, hydrology and soil, but in most cases these systems need further improvements through better technology, trained human resources, strengthened capacity and capital. The RCTWS has therefore built a data base system to keep regular records for all trainees, trainers, courses, etc. The number of trainees is about three thousand per annum, indicating the success of the RCTWS in meeting its objectives (Figure 6). The RCTWS also prepared the first regional course on Land Drainage in Agricultural Lands for three weeks, from November 20 to December 9, 2004. It is an intensive course for professionals involved in the management and performance assessment of drainage system on the farm level. The course improved individual technical and managerial capabilities by encouraging the exchange of skills and experience with colleagues and to create a human resource pool of highly skilled professionals in the area of land drainage on a farm level.

Figure 6: Number of Trainees during the period 1994 / 2004

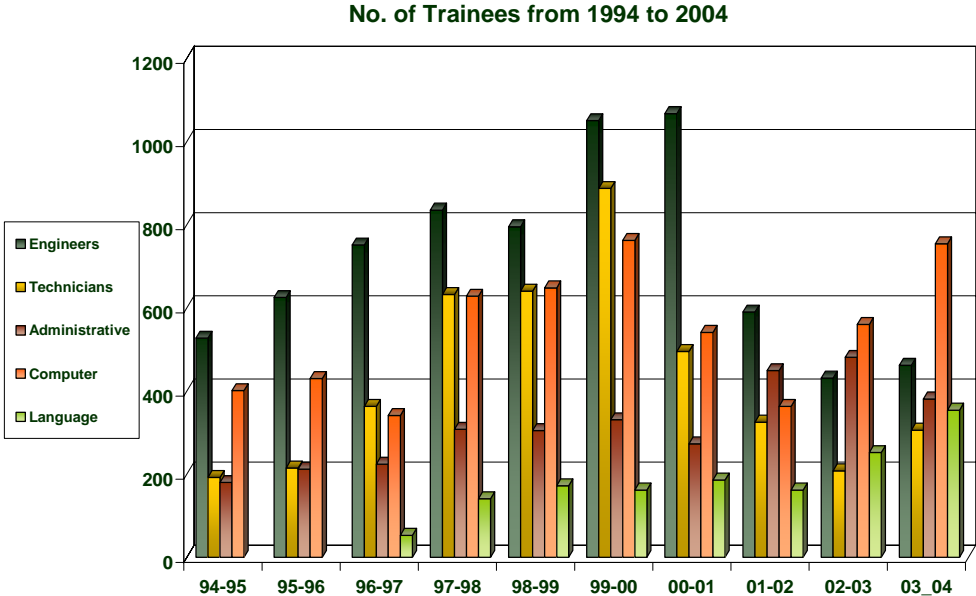

**CONCLUSION**

Water is the most manageable of natural resources, since it can be transported, stored, diverted and recycled. Limited water supplies have led to a growing interest in the rational use of this increasingly important resource. Consequently, reuse of agricultural drainage water and treated sewage effluent is an accomplished and accepted fact, with a high degree of social and political commitment. Plans have recently been formulated for large scale use of these non-conventional sources of water.

Given the health and the environmental hazards associated with the reuse of wastewater, the formulation of reuse plans and wastewater treatment is based on a well-established policy and is backed-up by adequate legislation governing the treatment and distribution systems as well as the reuse responsibilities and the role of various government agencies in law enforcement. Feasibility studies, capacity building and training are the key factors to achieving a successful transfer process. However, additional funding is required to make this happen. The RCTWS therefore has a pivotal role in transferring technology on the national and regional scale to serve the regional and Nile basin countries.

**REFERENCES**

Abdel-Gawad S.T., 1998. 'Agricultural Drainage Water Reuse Policy: Conservation and Challenges', Proceedings of Arab Water 98, Volume 1, Cairo, Egypt, April 26-28, 1998.

Abdel-Gawad S.T., 1998. 'Environmental Concerns, Health Risks and Mitigation Measures of Irrigation Water Pollution', Proceedings of International Workshop on Drainage Water Reuse in Irrigation, Sharm El-Sheikh, Egypt, May 3-5, 1998.

Abdel-Gawad, S.T., 2001. 'The Role of Water Reuse in Sustainable Agriculture in Egypt', Regional Workshop on Water Reuse in the Middle East and North Africa, 2-5 July, Cairo, Egypt.

Alnaggar, D., 2003. Water Resources Management and Policies for Egypt. Workshop on Policies and Strategies Options for Water Management in Islamic Countries, Tehran.

Arar A., 1998. 'Wastewater Reuse in the Arab World', Arab Water 98 Conference, Cairo, Egypt.

Attia, B. and Ezzat, M., 1999. 'Towards integrated water management in Egypt'. Ministry of Public Works and Water Resources, Planning Sector, Cairo, Egypt.

DRI, 1995. 'Reuse of Drainage Water in the Nile Delta: Monitoring, Modelling and Analysis', Report no. 50, DRI and SC-DLO, Cairo, Egypt.

DRI, 1997. 'Drainage Water Irrigation Project', Final Report, DRI and Louis Berger Int., Cairo, Egypt.

Riad M., 2000. "Wastewater Irrigation for Forest Plantation:", Report no. 34, MALR and USAID, Cairo, Egypt.

# **PUBLIC EDUCATION: AN EFFECTIVE WATER DEMAND MANAGEMENT STRATEGY**

Niaz Mazaraa – Public Relations Manager, Jerusalem Water Undertaking, Palestine

Email: [niaz@jwu.org](mailto:niaz@jwu.org)

## **ABSTRACT**

Water resources in the Middle East Region are far from fulfilling the needs of the population in Jerusalem, as they have been gravely affected by the Israeli-Palestinian conflict. On the one hand, Israeli military regulations and restrictions against Palestinian water rights limit the production and provision of water to Palestinians. On the other hand, Palestinian people lack enough knowledge and good practices regarding water and water resources in terms of their importance, availability, use, conservation and management. It is for this reason that the Jerusalem Water Undertaking (JWU) decided to tackle the issue of water conservation by raising public awareness and promoting good practices regarding water and enhancing public participation in water demand management in Jerusalem.

Initial levels of knowledge about water resources and water management were determined via a study of the knowledge, attitudes and practices of JWU's users, as well as a customer satisfaction survey. Based on the results of this initial research, and to achieve the campaign objectives, a number of activities were developed and implemented, including: a public awareness program with media broadcasts and promotional publications like brochures, World Water Day celebrations, a schools awareness program and summer camps, amongst others. The activities were based around central campaign themes that changed each year between 2001 and 2004. This paper examines the importance of such public education initiatives to help mitigate water shortages and manage demand.

## **INTRODUCTION**

The Jerusalem Water Undertaking (JWU) is an independent non-profit civil utility established in 1966. Today it has 220 employees and its service area expands over 600 square kilometers, including the north of Jerusalem, 10 municipalities, 39 villages and four refugee camps. It serves populations of 250,000, while the number of customers is 41,500, each with their own water meter. The network length is more than 1000 km. Samia Wells Field provides 20 percent of the water demand, and purchased water meets the remaining 80 percent of the water demand. Annual water supply is 12 million m<sup>3</sup>, and average consumption is 107 litres per capita, per day.

However, before the Intifada, water that was unaccounted for was 24 percent and rose up to 28 percent during the four years of Intifada.

## **PUBLIC RELATIONS CAMPAIGN**

Recognising the need to address water shortages in a more sustainable manner, and to begin to establish a means to account for the large percentage of unaccounted for water, a public relations department was established by JWU in late 2000, with an internal and external focus. The objectives were to improve JWU's image and its relations with customers, increase the awareness of the public regarding water shortage and rationalize the use of water by customers.

The JWU public relations department therefore launched a water consumption rationalization campaign targeting the local community in the Governorate as well as the population living in the surrounding areas. The campaign aimed at raising awareness amongst citizens about the importance of water, the need to preserve it, and how to avoid water loss and waste. This water use, conservation and management campaign was implemented from 2001 to 2004.

Figure 1: Map of Jerusalem Water Authority’s areas



The campaign planning incorporated five stages: 1) situation analysis, 2) activity design, 3) development of necessary material, 4) implementation and monitoring, and 5) reviewing, modifying and re-planning. Its ultimate goal was, according to the campaign slogan, ‘Promoting Better Water Consumption Behaviors and Practices’.

Campaign objectives included the following:

- promoting good knowledge, attitudes and practices towards the importance of water;
- protecting and preserving the existing water resources;
- minimizing the unwise use of water.

The project team comprised members of JWU management, public relations staff, water production supervisors and collectors as well as other members of the secondary target groups. These team members were trained in the following aspects of campaign management: definition of water deficiency problems, definition of the objectives of the public awareness campaign, mechanism and activities, and a training course on information, education and communication skills.

## ***Campaign Implementation***

In order to implement the campaign, basic studies were conducted, target communication channels defined – including mass media and individual and group education - and promotional materials were produced. These steps are outlined in more detail below.

First, a hierarchy of target groups was established. Primary target groups included: consumers being served, households, school children, factory owners, owners of workshops and institutions, and construction project managers for those constructions that consumed large quantities of water. Secondary target groups included: school teachers, members of social and sports centres, cultural centres, JWU employees, other water institutions and community leaders. These target groups were analysed to determine their respective levels of knowledge, attitudes and practices in regard to water.

Further, a customer satisfaction study was conducted by the end of 2001. Results defined the areas with high, intermediate and low levels of satisfaction with water supply, as well as their habitual practices and knowledge about JWU. From this, a work plan was derived, comprising a number of elements including an information, education and communication plan, training, services improvement and policy reviews. Additional campaign tactics are outlined briefly below.

### ***Media***

To ensure message dissemination, a number of mass media channels were selected, including three local television stations, radio stations, newspapers and the JWU newsletter. Advertisements were also produced for television and radio, addressing the following issues: water consumption, water harvesting and water meters protection.

### ***Promotional materials***

Additional supportive materials on water related issues were produced and distributed to the target groups. They included a puppet show, leaflets, posters, stickers, stories, games, coloring booklets and contests.

### ***Education and training***

Individual and group education comprised educational sessions and workshops delivered to small groups within the local community, utilizing leaflets and other publications.

### ***World Water Day***

Events are often central to effective public relations campaigns and JWU chose to focus on World Water Day, an internationally-recognised event. In Palestine, World Water Day was celebrated in different ways, with a different theme each year, as below:

- 2001: Water and Health
- 2002: Water and Development
- 2003: Water for the Future
- 2004: Water and Disasters

### ***Summer camps***

Each year JWU sponsored some of the summer camps organized in the area and provided clothing and educational materials that communicated about water issues, in accordance with the campaign's defined target messages. An evaluation of the summer camps activities was then conducted by a third party specialist, in order to determine achievements, measure the effect of JWU activities within the summer camps and design future strategies in this regard. As a result, the evaluation revealed that beneficiaries were satisfied and further activities were recommended for the future.

### ***Stage Performances***

Two puppet shows about water issues were composed for school children and performed about one hundred times.

### ***Curricula analysis***

Schools' curricula for grades 1 to 10 were analyzed to measure how water and water-related issues were tackled in the education system, and how it could be used to emphasize a water conservation culture.

### ***Training of trainers***

For the purpose of creating an awareness team in the schools, four train-the-trainer courses were organized for school teachers. Teachers are now playing the role of water awareness agents at their schools.

### ***Issue-based awareness: Greywater***

Examining issues related to greywater, awareness was raised about a number of issues such as:

- improving the public health by avoiding the overflow of grey wastewater near the drinking taps and the kitchen outlet
- creating new cheap source of water for irrigating the school garden, and saving the clean water for other important domestic uses
- decreasing the value of water bill
- decreasing the frequency of emptying the cesspit by 80 percent
- increasing the awareness level on water conservation among the teachers and the students.

### **Campaign constraints**

Some constraints influenced the implementation process and were not easily surmountable, including difficulties in moving around in the service area due to the occupation practices of Israeli Occupation Forces and the lack of staff dedicated to public awareness and education.

## **CAMPAIGN IMPACT**

The impact of awareness and behaviour change cannot be assessed in early stages of the awareness campaigns as it takes time to change the target audiences' behaviour. However, the evaluation conducted among the schools' summer camps showed that the results of the activities were very interesting and effective. It also indicated that such activities helped alleviate children's high stress levels that resulted from the Israeli re-occupation of West Bank.

Further, it can be said that knowledge about water and JWU's activities has increased in the target groups and the concept of water rationalization and related good practices has become clearer and more adoptable. The program has also had a positive economic impact on the local community since the allocated budget was dispersed in the local service market.

Lastly, in terms of international cooperation level, the program was an initiative of the cooperation between JWU and GTZ (a German company). It was also part of a triangular cooperation between JWU (Palestine), the Behaيره Water Company (Egypt) and Amsterdam Water Supply (the Netherlands).

## **CONCLUSION**

Water shortages and water loss are a real problem for Palestine, and improved water management and usage is critical to the future well-being of the territory's populations. The Jerusalem Water Undertaking, through a targeted public awareness campaign, sought to make the public aware of the water shortage problems and how to ration water use. Initial results suggest a positive change in attitudes of people towards water as a precious and finite commodity. Thus, although attitudinal change takes time, public awareness is immediately integral to effective water resource management. This approach is recommended for other cities and countries facing problems related to resource management.

# REFINERY WASTEWATER TREATMENT BY MICROFILTRATION AND ULTRAFILTRATION MEMBRANES

Noreddine Ghaffour, Middle East Desalination Research Center (MEDRC)

Tel. +968 695 351; Fax +968 697107 ; Email nghaffour@medrc.org.om

Jean Luc Negrel, Université de Montpellier, Science et Technologie, Département de Génie des Procédés,

Place Eugène Bataillon, 34090 Montpellier, France

Rahim Jassim, Jeddah College of Technology, Mechanical Engineering Department

Tahar Khir, Jeddah College of Technology, Mechanical Engineering Department

PO Box 42204, 21541 Jeddah, KSA

## ABSTRACT

Oil refineries produce wastewater containing oil and suspended solids (SS) with different concentrations. These effluents are in the flow-rate range between 500 and 1000 m<sup>3</sup>/h and treated by conventional processes. But the effluents obtained by these processes contain higher concentrations of oil and SS than those deemed acceptable by the international standards. Membrane processes such as microfiltration (MF) or ultrafiltration (UF) can be used to reduce these concentrations to acceptable levels and this study focuses on optimizing the operating parameters of UF for treating these effluents.

For the purposes of this study, the tubular inorganic composite Carbosep membrane was selected from among the tested membranes, since it acts as a total barrier for the oil and gives the highest water flux. A systematic study of the influence of the different operational parameters, in particular the cross-flow velocity in the membrane tube, the concentration of the retentate and the feed temperature, was conducted using a mixed suspension (MS) containing oil and biological solids sampled from an activated sludge plant. The importance of the feed water temperature was emphasized since it effects the droplet size distribution. The major limiting process conditions for fouling are determined and results are explained by the mean droplet size distribution. Aggregation processes of oil on the bacterial flocks were observed to lead to larger particles with an optimal oil/SS ratio. It was found that the flux performances strongly depend on temperature, with lower temperatures being preferable, due to formation of large particles due to agglomeration leading to higher flux. Experimental data were fitted to a model of cake deposition with reflux, which take into account the different particle deposition phenomena in both transient and steady state fluxes.

*Keywords: Ultrafiltration; Barrier Membranes; Modeling; Mixed suspension, Water treatment*

## INTRODUCTION

The oil refinery wastewater containing oil and SS is generally treated by conventional processes used by the refineries. The compositions of these effluents are as follows in Table 1 below:

Table 1: Conventional processes used in the companies

Process	Composition
Decantation	250 ppm oil and 110 ppm SS
Flocculation and decantation	40 ppm oil and 25 ppm SS
Biological treatment followed by flotation	20 ppm oil and 30 ppm SS



However, the new international standards require less than five ppm oil and less than 10 ppm SS in the effluent. Many membrane processes like microfiltration (MF) or ultrafiltration (UF) are able to achieve such standards, which are not possible by conventional processes. Nevertheless, the development of membrane processes for industrial wastewater treatment is hampered by relatively low flux performances, due to concentration polarization and fouling. Although there have been several studies of the membrane separation of oil/solvent in water emulsions, there is a lack of understanding of the basic phenomena which determine flux performance and oil rejection in these systems, to an extent that could impede engineering developments. Many companies have therefore initiated research and development programs to enhance basic understanding of these process limitations.

The cross-flow filtration has become a more attractive process in recent years owing to the advent of inorganic membranes [3]. Membrane technology covers a broad spectrum of pore sizes and materials. Membrane processes include MF, UF, nanofiltration (NF) and reverse osmosis (RO). MF and UF are in use on industrial scale to treat wastewaters, to concentrate milk and wine, in juice processing for clarification or in the concentration of latex particles. MF is particularly useful for the elimination of SS, bacteria, turbidity and microorganisms. UF is used to remove macromolecules, colloidal materials, viruses and constituents that have a larger molecular weight of greater than 10 000 Daltons. Since emulsion droplets are usually more than ten times the size of an average pore in a UF membrane, UF have been used for the removal of emulsions of oil from the effluents [11]. Several works have been reported using UF to treat oil emulsion wastewaters [11,12], but to the best of the author's knowledge, none has covered for suspensions containing oil and SS mixtures [7].

The first step towards the design of an efficient and economical treatment is the selection of an appropriate membrane. From an operational point of view, inorganic membranes are more suitable than organic ones [6]. Therefore a tubular Carbosep membrane was selected for this study. It was proved to be a total barrier for the oil contained in a synthetic emulsion made with Arabic crude oil, while giving the highest filtrate flux. A systematic study was conducted to examine the influence of the different operational parameters on the transient and steady state flux using this membrane at different temperatures. The study focused on the parameters which limit the mass transfer when oil is the sole solute [13]. This work mainly concentrated on mixed suspensions containing both oil and suspended solids.

## **MATERIAL AND METHODS**

### **Experimental unit**

The experimental unit, provided by the manufacturer Tech-Sep, is a tubular Carbosep membrane (40 cm long and 6 mm in diameter) operating in a closed loop, having provisions to recirculate the permeate and the retentate or both. To maintain the homogeneity of the feed solution, the unstable emulsion was continuously stirred and thermoregulated in a storage tank. If the droplets are deposited on the tank walls or on the liquid surface, the emulsion was recirculated in the tank by a centrifugal pump. The duration of each experiment ranged between 70 and 80 minutes.

### **Suspensions**

The suspensions are made with Arabic crude oil and the SS are collected from a settler of activated sludge plant. The oil and/or solids are diluted to the required level with the settler supernatant. The suspension is continuously stirred and thermoregulated in a storage tank at a concentration corresponding to the required retentate concentration. The industrial effluent has a concentration ratio of SS/oil of about 1.5, which is 20 ppm oil and 30 ppm SS, from biological treatment followed by flotation (Table 1).

## **ANALYSIS**

The number of particles and the particle size distribution are determined by a Malvern Mastersizer/E laser granulometer. Filtration flow-rate is determined by measuring the time required to collect a given filtrate volume. Dissolved organic carbon concentration is obtained after filtration through a 40 µm membrane and measurement with a TOC-meter 5000 Shimadzu. The analysis of the collected permeate is carried out with an oil content infrared analyzer OCMA-220 Horiba and with high pressure liquid chromatography.

### **Membrane regeneration**

After each experiment, the membranes were regenerated by the following procedure:

- 30 min static washing with a 3 percent sodium hydroxide solution
- tap water static washing
- 30 min static washing with a 3 percent in volume nitric acid solution
- tap water static washing

The initial water flux (tap water) of the membrane should be obtained after each regeneration to calculate the membrane resistance  $R_m$ .

## **RESULTS AND DISCUSSION**

### **Membrane selection**

Two inorganic membranes were tested. The first was an MF membrane with 0.14 µm rated mean pore diameter and the second was UF membrane of 300 000 Daltons cut-off, which corresponds to a pore size of 0.02 µm [6].

At low concentration, as no oil was detected in the product during the whole filtration run for the two tested membranes, the oil was therefore fully rejected. This could be explained by the relatively high surface tension of the oil droplets that induced forces higher than the forces caused by the applied pressure. However, for high concentration and high pressure (concentration of more than 30 percent and driving pressure more than 3 bars), the permeate contains around 100 ppm oil for the MF membrane, but an absolutely limpid permeate was obtained without any traces of oil until the membrane became fully blocked for the UF membrane. Both membranes were a total barrier for the suspended solids.

A typical decrease of the permeate flux was observed during the UF and MF operation before reaching a steady state after 70 minutes, as shown in Figure 1 (below). The highest flux of about 200 l/h.m<sup>2</sup> is obtained by the UF membrane. In subsequent experiments, the UF membrane which gave maximum permeation flux and is a total barrier for oil, was used.

Figure 1: Permeation flux against time, 2 g/l, 25 °C, 2 bars, 1.2 m/s.

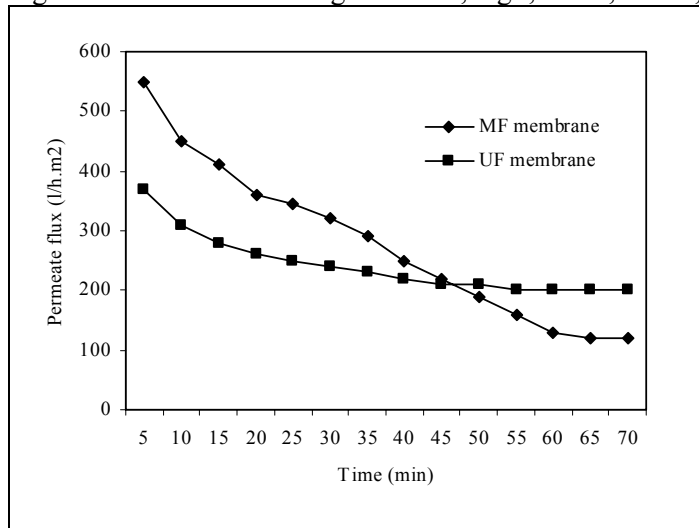

## INFLUENCE OF OPERATING PARAMETERS ON STEADY STATE FLUX

### Temperature

The presence of biological solids in oil emulsion increases the mean size of the particles, as shown in Figure 2a below. At 35 °C, the mean size of oil droplets alone in suspension is 2 µm whereas the biological solids alone have a mean size of 60 µm and are independent of the temperature. In the mixed suspension, the mean size becomes 80 µm (see Table 2 below). Microscopic observations showed that there is an agglomeration of oil droplets on the biological particles, which tend to flocculate, leading to clusters whose size are themselves independent of temperature. This phenomenon is more significant when the temperature increases from 25 to 35 °C (see Figure 3 below). This process reduces the fouling and hence the higher fluxes are observed in the presence of solids.

Table 2: Droplet size and standard deviations

Temperature (°C)	20		25		35	
Solution	Oil	MS	Oil	MS	Oil	MS
Mean size (µm)	69	80	9	70	2	80
Standard deviation (µm)	70	70	30	70	2	70
Diameter of the smaller droplets or particles (µm)	0.9	1.5	0.5	1	0.4	1

For the oil emulsion, two classes of droplets showing very different sizes, i.e. about 10 µm and about 120 µm, are evidenced at 20 and 25 °C (see Figure 3b below). Higher temperatures result in a decrease of the larger droplet frequency, inducing a significant decrease of the mean size which means a lower flux. However, the water viscosity is decreased at the same time and this should increase the flux.

As a matter of fact, a maximum is found at 25 °C and this could be explained by the conservation of some of the larger droplets which induce a relatively low deposit resistance (see Figure 4 below). On the other hand, while filtering MS, the flux reaches a plateau at 30 °C, which allows filtration at the industrial effluent temperature (see Figure 4).

Figures 2 (a) and 2 (b). Size distribution at different temperatures

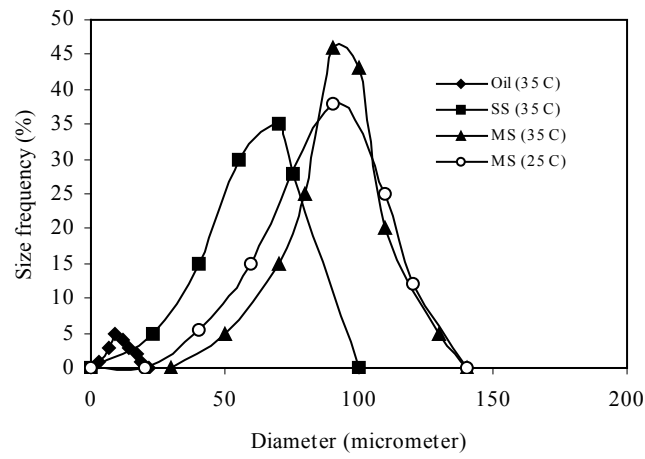

Figure 2 (a) Oil droplets, SS and MS particles

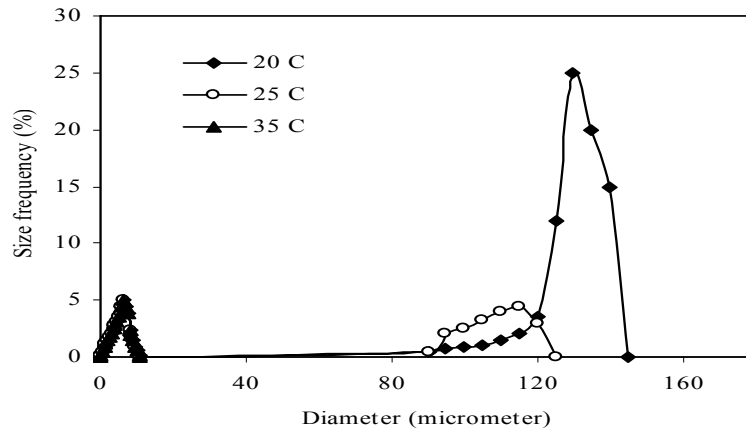
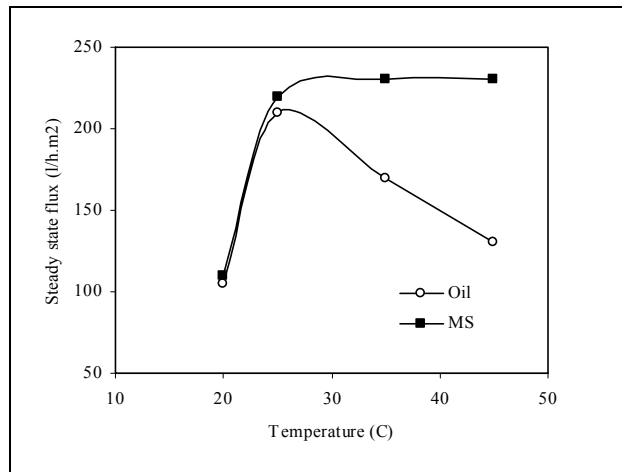

Figure 2 (b) Oil droplets only

Figure 3. Influence of temperature on steady state, 2 bars, 2 g/l oil, 3 g/l SS, 1.2 m/s.



## Feed concentration

The maximum flux is reached when the SS concentration is the same as the oil concentration expressed in mass per volume (see Figure 5 below). It was noticed that at 3 g/l SS, the steady state flux increased by increasing the concentration of oil to 3 g/l making the oil to SS ratio 1 (SS concentration equal oil concentration).

Figure 4. Influence of SS concentration on steady flux, 2 bars, 35 °C, 1.2 m/s.

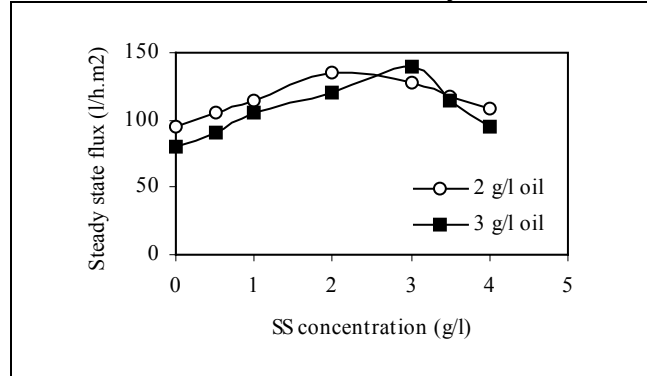

## Cross-flow velocity and shear stress

The shear stress  $\tau$  depends on the cross-flow velocity of feed solution [8]; it is calculated by the following relationship:

$$\frac{f}{2} = \frac{\tau}{\rho u^2} \quad (1)$$

Where  $f/2$  is the friction factor whose value is a function of the Reynolds number  $R_e = \rho u d / \mu$ ,  $\rho$  is the liquid density,  $u$  is the cross-flow velocity,  $d$  is the filtration element internal diameter and  $\mu$  is the liquid viscosity. The friction factor is then obtained by one of the following relationships:

$$\frac{f}{2} = \frac{8}{R_e} \quad \text{For } R_e \leq 4000 \quad (2)$$

$$\frac{f}{2} = 0.023 R_e^{-0.2} \quad \text{For } 5000 \leq R_e \leq 200\,000 \quad (3)$$

The experimental data plotted in Figure 6 (below) for the steady state flux versus shear stress shows that a plateau is reached at shear stress of around 5 Pascal irrespective of biological solids concentration. The flux with oil only is less than that of MS feed. There is therefore some irreversibility of the oil deposit, which cannot be transported towards the bulk flow of liquid by hydrodynamic effects. This phenomenon can be overcome with oleo-phobic membranes.

As shown in Figure 7 (below), the steady state flux increases when the cross-flow velocity is increased and reaches a plateau at about 2.2 m/s corresponding to a Reynolds number of  $12 \cdot 10^3$ , which represents a turbulent regime.

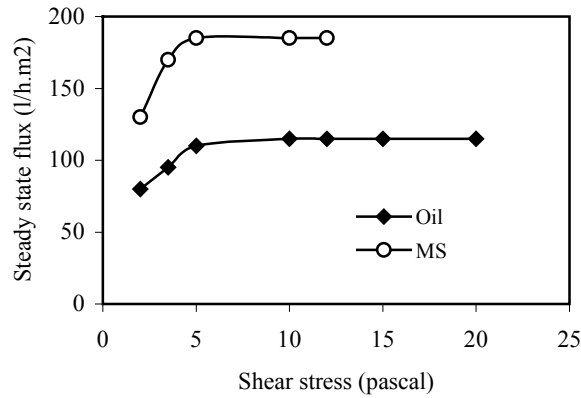

Figure 6: Steady state flux against shear stress.

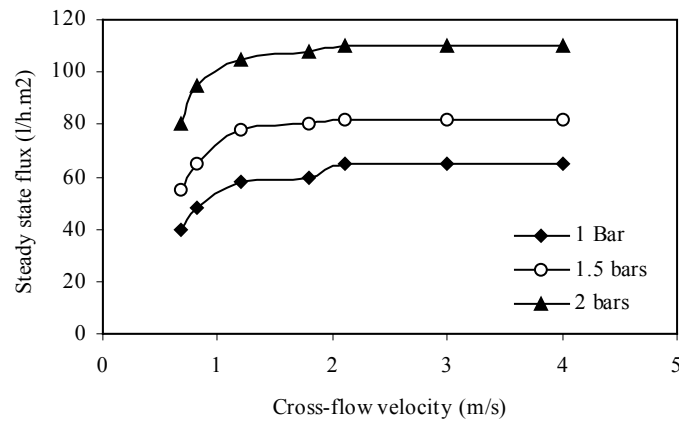
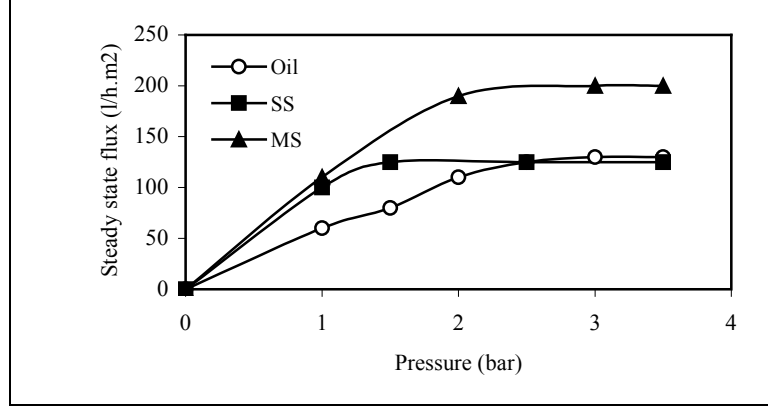

Figure 7: Steady state flux against cross-flow velocity.

## Driving pressure

Interestingly, the same value of plateau of steady state flux against transmembrane pressure was found for oil and SS alone (see Figure 8 below). But with the mixture of SS and oil, this value increases, in spite an increase in the concentration (Figure 8). This can be explained by the fact that the droplets agglomerate on the biological particles, which tend to flocculate, thus increasing the particle sizes and giving higher fluxes. The steady state flux value for the oil filtration is higher than the SS with the same concentration. This strange observation can be explained by the coalescence phenomenon on the membrane surface that is more significant than the particle flocculation.

Figure 8: Steady state flux against transmembrane pressure, 1.2 m/s, 35 °C.



### Evaluation of parameters in retroflux model

A general model for particle microfiltration was proposed by Liu [10]. This model takes into account the different particle deposition phenomena: the particles which are deposited against the membrane wall, the particles which contribute to an internal clogging and the particles which are transported from the deposit to the bulk of the liquid phase by a retroflux process. The filtration flow-rate  $Q$  as a function of time  $t$  and filtered volume ( $V$ ) is related by the equations below:

$$\frac{Q_o}{Q} = k_d(V - k_p t) + \frac{1}{[1 - k_i(V - k_p t)]^2} \quad (4)$$

Where:

$$k_d = \frac{\alpha x_o}{AR_m}, \quad k_p = \frac{Q_r}{x_o} \quad \text{and} \quad k_i = \frac{2x_o}{Nr_o^2 \pi L} \quad (5)$$

Where  $Q_o$  is the initial flow-rate and  $k_d$ ,  $k_i$  and  $k_p$  are respectively linked to the deposition, the internal clogging and the retroflux.  $r_o$  is the initial pore radius;  $L$  is the pore length,  $N$  is the number of pores.  $Q_r$  is the retroflux flow-rate and  $x_o$  is the volume fraction occupied by particles in the bulk of the suspension,  $A$  is the filtering surface area,  $R_m$  is the initial membrane resistance and  $\alpha$  is the specific resistance per unit length of deposit.

This model enables the calculation of a steady state of flux that can be reached when  $(V - k_p t)$  becomes constant. This approach will be used to quantify the UF data. In this study, there is no evidence of internal clogging by oil as they are fully rejected, and hence  $k_i$  is zero. The equation (3-4) can then be rearranged as:

$$\frac{\frac{Q_o}{Q} - 1}{V} = k_d - k_d k_p \frac{t}{V} \quad (6)$$

The plot of  $(Q_o/Q-1)/V$  against  $t/V$  is a straight line and enables calculation of both the parameters  $k_d$  and  $k_p$  (see Figures 9a and 9b below).  $k_d$  and  $k_p$  are respectively proportional and inversely proportional to the concentration as predicted by the equation 5 (Figure 9b).

Figures 9a and 9b respectively (below): Retroflux mod

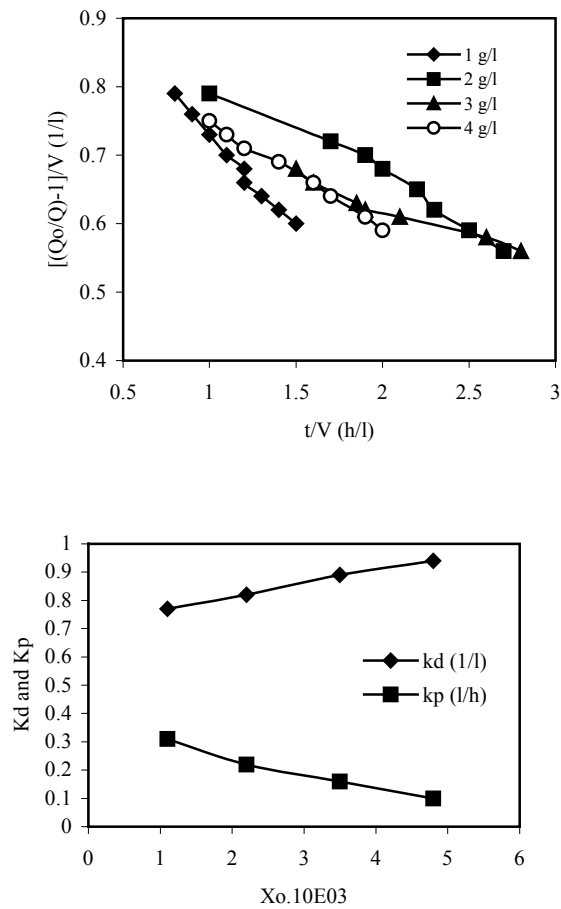

The retroflux flow-rate  $Q_r$  of oil emulsion remains steady between 20 and 45 °C, due to the droplet coalescence process on the membrane surface, while a lower viscosity increases the retroflux in the case of MS (Figure 10). Retroflux flow-rate is independent of the pressure for oil emulsion but decreases when the pressure increases for MS. This can be linked with an increase in the particle volume fraction, which can be transported from the deposit to the bulk of the liquid phase (Figure 11). On the other hand, the retroflux flow-rate is a decreasing function of the cross-flow velocity (Figure 12). This apparently surprising result can be due to the irreversible deposit of a particle layer and the incompressibility of increasing the flux by increase of the shear stress (Figure 6).

Fig. 10. Retroflux flow-rate Vs temperature.

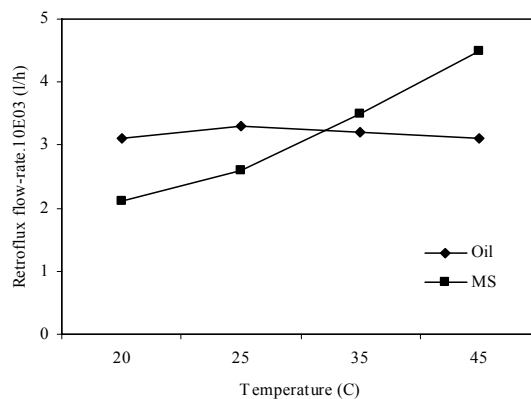



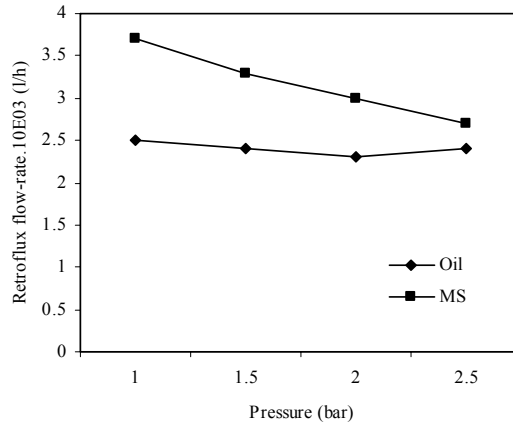

Figure 11: Retroflux flow-rate vs. pressure

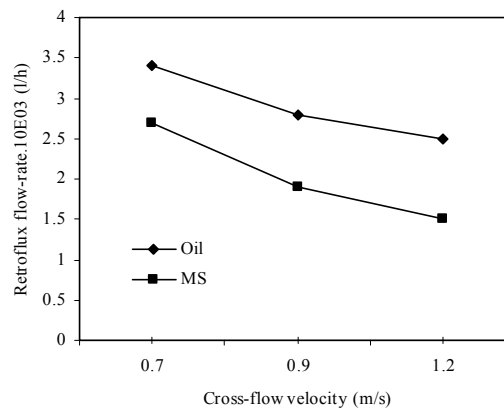

Figure 12 : Retroflux flow-rate vs. cross-flow velocity

## CONCLUSIONS

From the process/experiment above, a number of conclusions can be reached, as listed below:

- UF membrane produces permeate free of oil and SS, under any operational conditions.
- The oil droplets agglomerate on the biological solids maximizing the flux when a stoichiometric ratio is reached.
- For any feed concentration, the maximum flux is obtained when the oil/SS ration is equal to 1.
- The flux curves can be modeled by a deposition process associated with a retroflux towards the bulk of the liquid phase.
- The transient and steady state fluxes are satisfactorily quantified.
- For the same concentrations, the steady state flux of oil is higher than the SS one although the particle sizes are larger than the droplets one. The droplets coalescence phenomenon is more significant than the particles flocculation.

## REFERENCES

- [1] Aimar P. and Sanchez V., 1986, 'A novel approach to transfer limiting phenomena during ultrafiltration of macromolecules', *Ind. Eng. Chem. Fundam.*, 25, 789
- [2] Anderson G.K., Saw C.B. and Le M.S. 1987, 'Oil/water separation with surface modified membranes', *Environ Tech. Lett.*, 8, 75
- [3] Assadi M., White D.A., 1992, 'A model for determining the steady state flux of inorganic microfiltration membranes', *Chem. Eng. J.*, 48, 11-16
- [4] Audinos R., 1988, '*Les bases théoriques de l'ultrafiltration, Techniques Séparatives par Membranes*', PhD thesis, Toulouse, France
- [5] Chudacek M.W., Fane A.G., 1984, 'The dynamics of polarization in unstirred and stirred ultrafiltration', *Journal of Membrane Science*, 21, 145-160
- [6] Elmaleh S. and Ghaffor N., 1996, 'Upgrading oil refinery effluents by cross-flow ultrafiltration', *Water Science Technology*, Vol. 34, N.9, 231-238
- [7] Elmaleh S. and Ghaffor N., 1996, 'Cross-flow ultrafiltration of hydrocarbons and biological solid mixed suspensions', *Journal of Membrane Science* 118, 111-120
- [8] Gupta B.B., Field R.W., Howell J.A., Wu D., 1994, 'Helically baffled cross-flow microfiltration', *Engineering of Membrane Processes II*, Il Ciocco, Italy
- [9] Le Goff P., 1979, *Energétique Industrielle*, Volume 1, *Technique and Documentation*, Paris, France
- [10] Liu Ming Gang, 1992, '*Etude de la texture des Membranes et de leur Interaction avec des Suspensions au cours d'une filtration dynamique*', PhD Thesis, Compiègne, France
- [11] Marianne N., 1991, 'Ultrafiltration of O/W emulsions stabilized by limiting amounts of tall oil', *Colloids and Surfaces*, 57, 99-114
- [12] Michal B. and Krystyna K., 1992, 'The use of ultrafiltration membranes made of various polymers in the treatment of oil-emulsion wastewaters', *Waste Management*, Vol. 12, 75-84
- [13] Villarroell Lopez R., Elmaleh S., Ghaffour N., 1994, 'Cross-flow ultrafiltration of hydrocarbon emulsions' *Engineering of Membrane Processes II*, Il Ciocco, Italy
- [14] Wiley D.E., Fell C.J.D. and Fane A.G., 1985, "Optimization of membrane module design for brackish water desalination, *Desalination*, 52, 249
- [15] Yiantsios S.G. and Karabelas A.J., 'Colloidal fouling of desalination membranes and fouling indices', IDA World Congress on Water Desalination and Reuse, Manama, Bahrain, 2002

# WASTEWATER TECHNOLOGY IN YEMEN

Dr. Fadhil Ali Al-Nozaily, Water and Environment Center, Sana'a University, Republic of Yemen;

Email: d-fadl@maktoob.com

## ABSTRACT

The main objective of this paper is to review the existing situation of sanitation in the Republic of Yemen, including the activities and management undertaken by concerned bodies. Wastewater management will be assessed, including a review of projects under implementation and suggestions for better improvement. Specifically, the paper will discuss the level of coverage by the water and wastewater services, the treatment methods used in Yemen, sludge problems in Yemen, and the reuse of wastewater.

## INTRODUCTION

In Yemen, in response to urban development and high population growth, a water and wastewater network was constructed during the 1990s to manage household water influents and effluents. This led to wastewater disposal in cesspits (of two to three square meters in surface area and with depths of up to 20 meters). However, in many cases the cesspits flooded and overflowed into the streets of several of Yemen's main and secondary cities. In other cases, the cesspits were connected to an overloaded wastewater treatment system which also overflowed with blackwater, greywater and other forms of pollution. In some places, such as Al-Mukalla, a lack of wastewater treatment meant that wastewater was discharged into the sea. Further, despite the extension and increased construction of wastewater treatment plants, the concurrent production of more sludge proved problematic as it was unable to be adequately disposed off. This was particularly the case for some mechanical treatment plants, such as those under operation in Sana'a and Ibb cities, where hundreds of tons of sludge were unable to be disposed off. This paper therefore aims at reviewing and better understanding the existing situation of wastewater, sludge and reuse management in the Republic of Yemen, in order to suggest some measures for better management and better improvement.

## THE LEVEL OF COVERAGE BY WATER AND WASTEWATER SERVICES

Water scarcity and its ongoing depletion are considered as the major causes of the lack of adequate potable water available to consumers. It is estimated that 75 percent of the population of Yemen lacks wastewater services, while 50 percent of them cannot get clean drinking water. Moreover, these coverage percentages are decreasing with time due to continuous population growth and urban development, which do not correlate with increased services delivery in water and wastewater. For example the coverage of water services was decreased in urban areas from 50 percent in the year 2000 to 47 percent in the year 2002. The wastewater services coverage also decreased from 26 to 25 percent, respectively.

However, there is a distinction to be made between consumption patterns in different parts of the country: in rural mountainous regions consumption was about 30 litres per capita per day (l/c/d), while in the urban mountainous areas that was much higher at 70 l/c/d, with a slightly higher figure for the hot coastal areas.

This low water consumption has led to an increase in the pollutant concentration of wastewater. The wastewater BOD in the mountainous cities is three to four times the highest known concentration in the world while it reached only two times in case of coastal areas although there is enough water is available to some extent.

## TECHNOLOGICAL AND SANITATION PROBLEMS IN YEMEN

In some rural areas, dry sanitation is still applied to separate the solid (faeces) from the liquid parts of wastewater (ie liquids like urine, or those from washing, cleaning and ablution). The liquid wastewater is then used for irrigation while solid wastes are used as fertilizer. Due to the unhygienic nature of these applications, this method has almost been completely discontinued in urban areas, but is still being used in some rural areas.

Therefore, sanitation, and particularly the disposal of solid waste in rural areas, is considered a major problem which has become a health hazard for the population. In some rural and urban areas, cesspits are used as a means of wastewater disposal, and in cases where people are using dried wells as cesspits, groundwater basins are subsequently being threatened.

Other problematic factors include the disposal of used oil into the wastewater network and then into the wastewater treatment plants. A lack of adequate cleansing processes to remove and treat the presence of oil at the plants has led plant operators discharge the raw wastewater to the *wadi* without treatment, further risking contamination.

As there is only a limited number of industries with their own pretreatment systems in Yemen, the rest of the factories are discharging their wastewater into the public network without prior treatment and with no monitoring system applied. This has, in some cases, caused the death of the bacteria. In other cases, industrial effluents have been discharged directly into the cesspits, creating a contamination risk for the soil and groundwater.

### The treatment methods used in Yemen

In Yemen, three different technologies are used for primary and secondary (biological) wastewater treatment, as shown in Table 1 below. They are namely:

- a fully mechanical system, such as activated sludge systems, as used in Sana'a and Ibb cities in Yemen;
- a partial mechanical system, such as trickling filters, which were preceded by *imhof* tanks as is the case in Hajjah city;
- and natural system like waste stabilization ponds, as is the case in most of cities in Yemen: Aden, Amran, Rada'a, Al-Hodiedah, Dhamar, Yarim and Taiz, for example.

The sanitation sector faces many problems in terms of the operation and maintenance of the full and partially full mechanical systems, due to a lack of requisite skilled labour. The high cost of operation and maintenance is also problematic and is caused by the high cost of the spare parts, or a lack of spare parts due to discontinued production by industry. However, the need for experts to operate and maintain these complicated systems and the need for continuous training of system operators is considered secondary to the problem of a lack of spare parts.

Comparatively, waste stabilization ponds are easy to operate and maintain and their effluent is considered safe for irrigation provided that the minimum retention time for wastewater in the ponds is at least ten days, in order to be subjected to sunshine (light) and undergo appropriate treatment.

Although these systems are seemingly easy to maintain, water and wastewater corporations face many difficulties in securing adequate space to build and develop their operations and to extend the reach of services. Moreover, proper care of these systems is often neglected, despite the fact that they are quite simple, as in the case at Al-Hodiedah, Taiz and Dhamar cities.

Another problem affecting the treatment process is the scarcity of water and concurrent consumption rates that are decreasing with time due to its unavailability. This low water consumption causes an increase in wastewater pollutant concentrations. For example, BOD was increased from 500 mg/l

during the 1980s to 800 mg/l during the 1990s and then to 1200 mg/l at the beginning of the year 2000. This increase caused malfunctioning of the treatment plants that were designed in the 1980s and constructed at the end of 1990s – plants such as Ibb and Sana'a (see Table 1 below). These wastewater treatment plants became organically overloaded before the full hydraulic capacity was achieved and before the designed period was reached.

Table (1) Existing wastewater treatment systems at different cities in Yemen

Variables	Units	Sana'a	Ibb	Hajjah	Aden*	Amran	Rada'a	Al-Hodiedah	Dhamar	Yarim	Taiz
Used Technol.	-	Activated sludge		Imhof tank followed by trickling filter	Waste stabilization ponds						
End Design period	Year	2005	2005	2005	2013	2005	2010	2000	2005	2005	2000
Situation of the WWTP	---	OVER LOADED		IN THE RANGE OF THE DESIGN CAPACITY				Over loaded	In the range of the design capacity	Just started	Over loaded
Start operation	Year	2000	1993	1998	2000	2002	1995	1983	1991	2003	1983
Actual flow rate	m <sup>3</sup> /d	36000	7 000	1200	17000	1100	1500	18000	6 000	---	8000
Design flow rate	m <sup>3</sup> /d	50,000	5256	2428	70000	1480	1881	12000	11000	1771	9000
Design BOD	mg/l	500		843	312	800	500	280	1000	700	500
Actual BOD	mg/l	1200	1316	1100	372	1518	900	582	900	962	1000
Reuse of effluent	---	Restricted irrigation									

\*In addition to this treatment plant (Al-Arish), there is other treatment plant called (Al-Shaab) with an existing capacity of 15,000m operated in two parts 1979 and 1989

## SLUDGE PROBLEM IN YEMEN

Sludge is produced during treatment at the wastewater treatment plant and is estimated as 60 to 80 percent of BOD load. In the case of mechanical treatment, the sludge is produced on daily basis and treated by thickeners and then dried in drying beds.

At the moment, mechanical systems in Yemen are having difficulties drying the solids, which require bigger areas for the drying beds, as insufficient space is available. This is ironic because usually the mechanical system is chosen for its comparative compactness: it does not require as much space as, for example, natural systems such as waste stabilization ponds.

Solid waste treated by the mechanical system should, after treatment, be able to be easily taken away from the site and used as fertilizer. In the meantime, the sludge treatment is limited to thickening up to solid concentration of five percent, then the sludge is pumped into a drying beds to dry it up to 40 percent dry solids. Before the sludge is pumped into the drying beds, a polymer material is used to agglomerate the solids and facilitate the separation of water from solids, which ultimately decreases

the drying time as the digesters are not used. Although the period designed for the sludge to remain in the drying beds is 14 days, the actual period applied is usually 20 days, including the addition of the polymer. After this time however, the sludge is still not suitable to be used as a fertilizer – even as a domestic fertiliser – because it has not been treated to remove the pathogenic bacteria which would affect the farmers.

At present, due to the absence of sufficient space to install enough drying beds, it is intended to construct anaerobic digesters in order to digest and disinfect the sludge, at the same time converting the biogas resulted from the digestion into electrical and thermal energy to be utilized in the site. Nevertheless, this technology is very precise and also requires highly skilled labour, which is not necessarily available. On the other hand, in those cities that use waste stabilization ponds (WSPs) technology, the sludge itself is considered as a more suitable fertilizer that if treated, as it stayed for six months to one year drying in the anaerobic ponds that were constructed at the beginning of the treatment systems.

## **REUSE OF WASTEWATER TREATMENT**

Currently, wastewater effluent is used in restricted irrigation, although it still not yet treated enough to be ready for irrigation (Table 1). However, some anomalies have been found, as follows:

- wastewater effluent after treatment that is not legally to be used for irrigation, has been used;
- the effluent is mixed with raw water discharged from time to time due to the excessive discharges and oil that enters the treatment plant;
- some people are opening the manholes and clogging the effluent to stop the water flowing to the treatment system, and then pumping it to the fields for irrigation.

These unusual situations create health hazards and although there are efforts to stop them legally, there is still the need for improvement. Nevertheless, there is a plan to implement several more projects focused on the safe reuse of water that also complies with international standards.

## **CONCLUSION**

In order to protect the environment, wastewater should never be disposed of directly without any treatment.

As Yemen is a developing country with scarce water resources, there is a need to increase the wastewater concentration on the one hand and to reuse the wastewater effluent after treatment on the other. Thus the treatment system applied should be robust in terms of efficiency and cost, meaning that systems like that of a WSP, in combination with anaerobic system, should be applied.

Building capacity is therefore an important action in order to improve the management skills for wastewater and sludge treatment.

## REFERENCES

Metcalf and Eddy (2000) *Wastewater Engineering; Treatment and Reuse*. McGraw Hill.

Arthur, J. P. (1983) 'Notes on the Design and Operation of Waste Stabilization Ponds in Warm Climates of Developing countries', World Bank Technical Paper No. 6, IBRD, Washington DC.

National Water and Sanitation Authority (1995). 'Water supply and sanitation in provincial towns', Contract No. 2, Hadjah, Bidding documents, Sana', Republic of Yemen. Prepared by: Gitec & Dorsch Consult GMBH, Germany.

Veenstra, S.; Al-Nozaily, F.; and Alaerts (1995). 'Purple non-sulfur bacteria and their influence on waste stabilization pond performance in the Yemen Republic'. *Water Science Technology*. 31 (12) pp: 141-149.

Yanez, F. (1980) 'Evaluation of the San Juan Stabilization ponds'. Final research report CEPIS/WHO/IDRC. Lima.

التقارير الشهرية حول محطة مياه الصرف الصحي بصنعاء للسنوات 2000-2004 (لم تنشر)، المؤسسة المحلية للمياه والصرف الصحي - صنعاء - الجمهورية اليمنية.

تواصل شخصي، مختلف المسؤولين في المؤسسات المحلية المختلفة، صنعاء، عدن، حجة، الجمهورية اليمنية.

# OVERCOMING CONSTRAINTS IN TREATED GREYWATER REUSE IN OMAN

SA Prathapar, Department of Soils, Water & Agricultural Engineering, Sultan Qaboos University, Al Khod, Oman; Email: prathapar@squ.edu.om.

A.Jamrah, Department of Civil Engineering, Sultan Qaboos University; M. Ahmed, Department of Soils, Water & Agricultural Engineering, Sultan Qaboos University; S. Al Adawi, Department of Soils, Water & Agricultural Engineering, Sultan Qaboos University; S. Al Sidairi, Department of Civil Engineering, Sultan Qaboos University; A. Al Harassi, Department of Civil Engineering, Sultan Qaboos University.

## ABSTRACT

The Sultanate of Oman is an arid country with a rapidly developing economy and a high population growth rate. Together, these factors have increased the demand for freshwater. In response, the Sultanate has developed well fields and installed desalination plants across Oman. Albeit meeting the demand for freshwater, such investments are straining the country's financial and natural resources. Experience in several arid and semi-arid countries indicates that greywater can be a cost-effective alternative source of water. However, a lack of data on this alternative has impeded the widespread knowledge about and acceptance of it, up until recently. Ahmed et al. (2003), Jamrah et al (2004) and Prathapar et al. (2004) have recently collected relevant data which reveal that there are several factors constraining treated greywater reuse in Oman. For the purposes of this paper, they are categorized as quantity, quality, financial, legal, social and institutional constraints. The possible means of overcoming these constraints are also discussed.

## INTRODUCTION

The Sultanate of Oman is an arid country with a rapidly developing economy and a high population growth rate, factors that have increased the demand for freshwater in recent years. In response, the Sultanate has developed 623 well fields and installed 43 desalination plants across the country. The well fields produce 6309 million gallons per annum (78500 m<sup>3</sup>/d approximately) and desalination plants have a total production capacity of 44.4 million gallons per day (202000 m<sup>3</sup>/d approximately). The freshwater is distributed to consumers at a price that varies between 1.14 USD/m<sup>3</sup> and 1.71 USD/m<sup>3</sup>, depending on the sector (domestic or industrial) and the level of consumption (MHEW, 2002). These prices are believed to be subsidized by the Government, implying that the actual cost of water production and distribution is somewhat higher than the sale price. Furthermore, pumping out groundwater for domestic, industrial and agricultural purposes has resulted in decline in the groundwater levels and coastal salinisation across the country. Hence it may be surmised that the demand for freshwater is straining the country's financial and natural resources.

This condition is attributable to many factors, but a fundamental problem is the perception that freshwater is required to meet all demands for water, from drinking to gardening. This paradigm of water consumption must shift to one that promotes the consumption of adequate amounts of water of acceptable quality. Such a paradigm shift will convert *freshwater* uses and users to *water* uses and users, and therefore reduce pressure on the freshwater reserves and demands of the Sultanate. This shift also requires that alternative sources of water are identified, and appropriate technology is developed to harness them.

Experience in several other arid and semi-arid countries indicates that greywater can be a cost effective alternative source of water. Greywater is defined as water from baths, showers, washing machines and bathroom sinks. Some sanitary experts define greywater as water that is lower in quality than potable water (drinking water), but of higher quality than black water (toilet effluents). Greywater decomposes much faster than blackwater and contains fewer pathogens, making it easy to treat.



Furthermore, separation of greywater from blackwater will result in septic tanks of smaller sizes, lowering wastewater treatment costs and minimizing the potential for groundwater contamination.

Greywater has been used to promote sustainable development and resource conservation without compromising public health and environmental quality. Griggs et al. (1996) identified greywater reuse for irrigation and toilet flushing as a major water conservation measure. In a study conducted in the city of Los Angeles (Sheikh, 1993) on the utilization of greywater effluents for irrigation, 12 to 65 percent of water savings were observed. The study also noted that the water-savings potential of individual homes can be significant and as high as 50 percent of the total water used. An Australian experience shows that reuse of greywater for toilet flushing and lawn-gardening could achieve water savings from 30 to 50 percent of the total household water usage. Additionally, typical water savings in the range of 0.5 to 2 litres were observed per event when hand-wash water was used to flush the toilet (Jeppesen, 1996).

Despite several environmental and financial benefits, constraints associated with greywater production and treatment hinder successful implementation of a reuse strategy in Oman. In this paper such constraints are identified and classified as quantity, quality, social, financial, legal and institutional constraints. Potential means by which they may be overcome are also presented.

## **QUANTITY CONSTRAINTS**

### **High percentage but small volumes: greywater production in Omani households**

There have been many studies in the UK, USA, Europe and Australia in which greywater production has been quantified. Surendran and Wheatley (1998) reported that in the United Kingdom, on an average, approximately equal quantities of greywater and black water were produced. Hodges et al. (1998) reported that about two thirds of domestic water was greywater.

Data on household greywater production in Oman is not available at present. In order to rectify this deficiency, Jamrah et al (2004) collected qualitative data on water-related activities through a survey, and data on water consumption per activity (as reported by the Ministry of Housing Energy and Water) to estimate the total greywater produced in Omani houses

The survey was conducted in 221 households with 1543 occupants, representing an urban population of similar lifestyle, culture and income. Information collected included the type of dwelling, number of occupants, floor area of the house, water meter reading, type of washing machines (manual, semi-automatic or automatic), number of washing cycles per week, frequency of showers, frequency and type of sink use for hand washing, teeth brushing, ablution and hair washing, frequency of toilet flushing, frequency of kitchen and bathroom floor-washing and frequency of garden watering.

Survey results (see Table 1 below) revealed that greywater production among households varied widely (high coefficient of variation = CV). The average per capita freshwater consumption was about 195 litres per day (lpd), and 82 percent of this quantity could be classified as greywater. This is higher than the percentages reported by Surendran and Wheatley (1998) and Hodges et al. (1998).

The differences may be due to (a) Jamrah et al.'s (2004) estimates based on a qualitative survey, and (b) Hodges et al. (1998) and Surendran and Wheatley (1998)'s data from temperate countries of Western culture, whose attitude towards water and water use are different from those live in a Middle Eastern Islamic country.

Jamrah et al. (2004) observed that greywater generated in Omani households would be independent of the floor area, but dependent on the size of the family. Greywater production increased with family size, but per capita greywater production decreased with the family size.

From the study by Jamrah et al., it is reasonable to conclude that a large portion of water consumed in Omani household ends up as greywater and the volume of greywater produced at houses vary widely, depending on the size of the household.

Table 1. Summary of greywater use estimates (l/person/day).

	Laundry	Shower	Sink	Kitchen	Greywater	Blackwater	Garden	Cooking	Total
Mean	13	83	9	55	161	11	10	18	195
Std Dev.	13	51	8	53	90	11	5	14	103
C.V.	0.96	0.61	0.86	0.97	0.56	0.98	0.53	0.76	0.53

The variability in greywater produced in different households may not constrain greywater treatment and reuse, but the levels of greywater production could. Based on the data presented above, average households of eight occupants would produce approximately 1200 lpd, which is considered by the greywater industry too small an amount to develop greywater treatment systems commercially.

### **Large volumes but not reliable - Greywater production at mosques**

A significant source of greywater in Oman is the ablution water at mosques. Worshippers wash before each prayer and most mosques have ablution rooms with separate plumbing to drain water separately from black water. Prathapar et al. (2004) studied variations in the quality and quantity of greywater produced at two mosques in Oman. Their results were based on 25 weeks of data collection, beginning in October 2003, whereas results presented here are based on 42 weeks of data collection, beginning in October 2003.

The first mosque at which data was collected is located at the Sultan Qaboos University (SQU). The number of worshippers per day varies from less than 100 to a few thousand, depending on the day of the week and whether the students are on leave. Weekly water use data has been collected since October 2003 and two sets of daily data for a two-week period were collected. The first was in January 2004 when students were on leave and the second was in February 2004 when the students were on campus. Weekly greywater production at the SQU mosque ranged from 32.6 m<sup>3</sup> to 111.2 m<sup>3</sup>. Average weekly greywater production was 63.7 m<sup>3</sup>, ( $\pm 15.5$  m<sup>3</sup>), with a coefficient of variation of 0.27. The primary reason for the wide range of greywater production at the SQU mosque was that the students were on leave for a period of five weeks during the data collection period. Daily greywater produced at the SQU mosque during holidays ranged from 0.84 m<sup>3</sup> to 3.17 m<sup>3</sup>. Average daily greywater production was 2.05 m<sup>3</sup>, ( $\pm 0.56$  m<sup>3</sup>), with a coefficient of variation of 0.27. Comparatively, daily greywater produced at the SQU mosque during semester ranged from 1.31m<sup>3</sup> to 15.4 m<sup>3</sup>. Average daily greywater production was 6.6 m<sup>3</sup>, ( $\pm 4$  m<sup>3</sup>), with a coefficient of variation of 0.61.

The second mosque is located in Al Hail South. The number of worshippers during a day may vary from a small number to a few hundred depending on the day of the week or events hosted by the mosque for members of the community. In general, the number of worshippers was high on Fridays. Weekly water use data has been collected since October 2003.

Daily water use data were collected for a two-week period in January 2004. The greywater produced every week at the Al Hail South mosque ranged from 4.1 m<sup>3</sup> to 17.6 m<sup>3</sup>. The average weekly greywater production was 9.93 m<sup>3</sup> ( $\pm 2.7$  m<sup>3</sup>), with a coefficient of variation of 0.27. Greywater production was high during weeks when the mosque hosted a community event. Daily greywater

produced at the Al Hail South mosque ranged from 0.77 m<sup>3</sup> to 1.94 m<sup>3</sup>. The average daily greywater production was 1.47 m<sup>3</sup>, ( $\pm 0.38$  m<sup>3</sup>), with a coefficient of variation of 0.26.

Analysis of daily and weekly greywater production data from both the mosques indicates a high degree of temporal variability in the amount of water produced on a daily basis. This makes the supply of greywater unreliable. However, the reliability of treated greywater can be increased if it is stored before use.

## Quality Constraints

Greywater quality depends on the water source, plumbing system, living habits, personal hygiene of the users and types of greywater such as commercial, domestic or industrial. Other factors such as cleaning products used, dishwashing patterns, laundering practices, bathing habits and disposal of household chemicals will also influence the characteristics of greywater. As a result, the physical, chemical and biological characteristics of greywater vary greatly among families and businesses.

Omani household greywater quality data reported by Jamrah et al (2004) are summarized and assessed in relation to the standards set by the Ministry of Regional Municipalities Environment and Water Resources, as presented in Table 2 below. Results obtained are similar to those reported by Jeppesen (1996) and Stephenson and Judd (1998). Results show that there is a considerable variation in quality among sources of greywater. Since most greywater is produced from showers, a comparison of shower water quality and Omani standards is made in Table 2. It reveals that greywater from Omani households would require treatment before reuse. Results also show that laundry water is highly contaminated (Table 2), but the volume is small (Table 1). Therefore, it can be disposed of together with blackwater and the remaining water from households may be separated as greywater.

Table 2: Quality of greywater from Omani houses.

	Unit	Shower	Sink	Laundry	Standard A <sup>1</sup>	Standard B <sup>2</sup>	Acceptability
Total Solids (TS)	mg/l	683	817	2700			
Total Suspended Solids (TSS)	mg/l	353	505	315	15	30	N
Total Dissolved Solids (TDS)	mg/l	330	312	2385	1500	2000	Y
Total Fixed Solids (TFS)	mg/l	268	355	877			
Total Volatile Solids (TVS)	mg/l	416	462	967			
Fixed Suspended Solids (FSS)	mg/l	221	158	105			
Volatile Suspended Solids (VSS)	mg/l	133	347	210			
Turbidity	NTU	375	133	444			
pH		7.4	7.1	8.3	6-9	6-9	Y
Dissolved Oxygen (DO)	mg/l	2.6	3.0	2.9			
Conductivity	mS/m	1.4	1.5	2.9	2	2.7	Y
Alkalinity	mg/l	15.0	13.3	28.3			

<sup>1</sup> A: Fruits & Vegetables likely to be eaten raw. Areas with public access.

<sup>2</sup> B: Fruits and Vegetables likely to be cooked and eaten. Areas with no public access.

	Unit	Shower	Sink	Laundry	Standard A <sup>1</sup>	Standard B <sup>2</sup>	Acceptability
Total Organic Carbon (TOC)	mg/l	83.5	70.2	174.6			
Nitrate	mg/l	28.7	10.2	25.8			
Surfactants	mg/l	14.9	41.9	118.3			
Chemical Oxygen Demand (COD)	mg/l	294.3	58.0	231.3	150	200	N
Biological Oxygen Demand (BOD)	mg/l	130.0	42.1	179.7	15	20	N
Ca	mg/l	15.7835	19.6953	18.7334			
Mg	mg/l	56.0771	20.9806	60.8399	150 mg/l	150 mg/l	Y
Na	mg/l	184.4993	148.9361	667.1468	200 mg/l	300 mg/l	Y
K	mg/l	43.1312	5.5405	23.4326			
Zn	mg/l	2.4256	0.0392	0.1373	5 mg/l	5 mg/l	Y
Fe	mg/l	ND	ND	ND	1 mg/l	5 mg/l	Y
Al	mg/l	0.0135	0.0108	0.0810	5 mg/l	5 mg/l	Y
Ba	mg/l	0.0000	ND	ND	1 mg/l	2 mg/l	Y
As	mg/l	0.0300	0.0150	0.0000	0.1 mg/l	0.1 mg/l	Y
Cd	mg/l	ND	ND	ND	0.01 mg/l	0.01 mg/l	Y
Pb	mg/l	0.1036	0.0622	0.0829	0.1 mg/l	0.2 mg/l	Y
Cu	mg/l	0.0127	0.0000	0.0064	0.5 mg/l	1 mg/l	Y
Ni	mg/l	0.0352	0.0352	0.0352	0.1 mg/l	0.1 mg/l	Y
Coliform	MPN	>200.5	>200.5	>200.5			N
E Coli	MPN	>200.5	>200.5	>200.5			N

End of Table 2

Prathapar et al. (2004) analysed ablution water samples from mosques in terms of pH, electrical conductivity, turbidity, dissolved oxygen, BOD<sub>5</sub>, COD, coliforms, E. Coli, total suspended solids, total dissolved solids and total carbon. Table 3 (below) shows the results compared with wastewater reuse guidelines in Oman. The results show that the pH, E.C. and TDS of greywater produced at both mosques are within limits of water suitable for irrigation, but the BOD<sub>5</sub>, COD, Coliform and E.Coli levels exceed permissible concentrations, requiring treatment before reuse.

Table 3: Quality of greywater at Al Hail South mosque and at SQU mosque

Parameter	Unit	SQU			Al Hail South			Standard A <sup>3</sup>	Standard B <sup>4</sup>	Acceptable
		n	Mean	S.D.	n	Mean	S.D.			
pH		17	7.10	0.24	14	7	0.39	6-9	6-9	Y
E.C.	μS cm <sup>-1</sup>	17	219	34	14	240	52	2000	2700	Y
BOD <sub>5</sub>	mg l <sup>-1</sup>	17	61	22	14	58	38	15	20	N
COD	mg l <sup>-1</sup>	11	163	60	7	158	104	150	200	N
Coliform	N/100 ml	16	3522	3115	9	3378	5832	200	1000	N

<sup>3</sup> A: Fruits & Vegetables likely to be eaten raw. Areas with public access.

<sup>4</sup> B: Fruits and Vegetables likely to be cooked and eaten. Areas with no public access.

Parameter	Unit	SQU			Al Hail South			Standard A <sup>3</sup>	Standard B <sup>4</sup>	Acceptable
		n	Mean	S.D.	n	Mean	S.D.			
TSS	mg l <sup>-1</sup>	17	25	22		34	15	15	30	N
TDS	mg l <sup>-1</sup>	17	120	19		132	28	1500	2000	
E.Coli.	N/100 ml	16	110	214	11	15	40			
Turbidity	NTU	17	34	17	14	51	36			
D.O.	mg l <sup>-1</sup>	17	5.63	1.43	14	4.81	1.88			
TC	mg l <sup>-1</sup>	11	67	37	7	67	30			

In addition to variation in quality among sources within a house, quality also varies with time. This is evident in the data reported by Ahmed et al. (2003), presented in Table 4 (below).

Table 4. Temporal variation in greywater quality

Source	pH		EC dS/m		BOD <sub>5</sub> mg/l		Turbidity NTU		DO mg/l	
	Week 1	Week 2	Week 1	Week 2	Week 1	Week 2	Week 1	Week 2	Week 1	Week 2
Fresh	8.04	-	1.55	-	0.7	-	0.56	-	6.2	-
Hand Basin	7.63	7.4	1.52	1.74	70.3	Low	49.0	23.6	3.2	2.6
Shower	7.84	7.4	1.54	1.0	99.4	141	52.1	228	5.7	2.0
Washing Machine	8.79	8.1	3.18	2.47		240	876	480	2.3	0.8
Kitchen Morning	6.30	5.5	1.53	1.73	546	614	213	378	1.7	1.4
Kitchen Noon	6.25	7.1	1.64	1.99	315	84.7	79.9	84	1.3	1.8
Kitchen Night	6.68	7.0	1.62	1.84	386	42.4	2.67	33.1	1.8	2.0

Considering the data reported by Jamrah et al (2004), Prathapar et al. (2004) and Ahmed et al. (2003), and comparing them with Omani standards for treated wastewater reuse, it is reasonable to conclude that greywater quality in Oman varies among sources, and with time, and has to be treated before reuse.

## OVERCOMING QUANTITY AND QUALITY CONSTRAINTS

High variability in terms of quantity and quality of greywater, which is the case in Oman, can pose serious complications for the design, operation and maintenance of greywater treatment facilities. Greywater treatment systems require rigorous maintenance. Many greywater treatment systems fail because adequate effort is not provided to maintain installed systems.

During storage of untreated greywater, suspended solids settle, aerobic microbial activities increase, anaerobic release of soluble COD increases and atmospheric re-aeration occurs. Storing greywater for 24 hours may improve the water quality by rapid settlement of solid particles, however, storage beyond it leads to depleted dissolved oxygen levels and other aesthetic problems (Dixon et al. 1999).

Greywater is usually treated sequentially, as below (Surendran and Wheatley, 1998, Shouler et al. 1998):

Storage of Greywater: Untreated greywater cannot be stored for more than 24 hours, because it will turn septic due to microbial activity. It is recommended that the size of the storage tank is at least 2.4 times the maximum expected flow to allow sludge accumulation and sludge loading.

Balancing and screening: The greywater can be acidic or alkaline, depending on its contaminants. This requires pH balancing. Furthermore, greywater may contain solid particles including hair, which has to be screened.

Anaerobic treatment: This is allowed to improve the Biological Oxygen Demand status of the greywater.

Aerobic treatment: This may include aeration, flotation, dilution and addition of chemicals such as alum, lime, or chlorine.

Slow filtering: Filtering may include slow sand filters and carbon filters to remove odor and toxins.

However, the final design depends on quality, quantity and timing of greywater generated, soil and climatic conditions, and legal requirements. Successful designs are simple, require minimum energy, and are in a position to receive greywater any time and treat it.

In almost all cases reported in Oman, the TSS, BOD<sub>5</sub>, COD, DO, Coliforms and E. Coli exceed Omani wastewater reuse standards. Laboratory tests showed that 200 ml of greywater with less than 200.5 MPN Coliform and E.Coli can be treated with 0.3 ml of chlorine solution at 4.5 mg/l concentration; and home-made sand filters have shown to be effective in removing suspended solids from greywater. Therefore, a low cost treatment system (Figure 1) may be designed as per the process outlined below, and depicted in Figure 1 (below). Initially, water is sent through a settlement pond (A) to a greywater storage tank (B). Pond A traps solids which are denser than water, and it should be cleaned periodically. Water collected and stored in B during the day will be chlorinated and lifted to sand filters C at night. Filtered water will be stored in Tank D for reuse later.

Figure 1: A low cost greywater treatment system

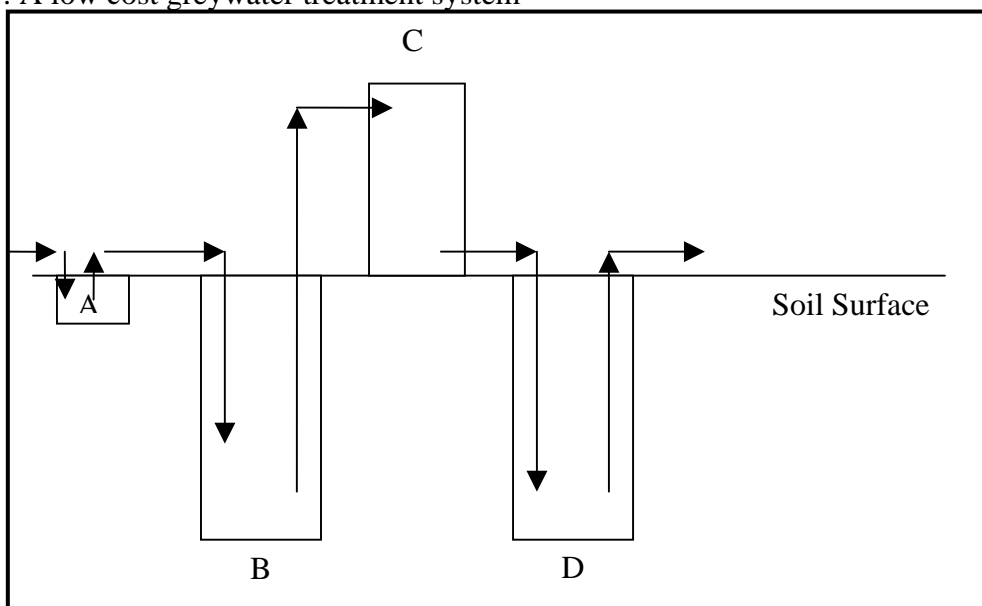

## SOCIAL CONSTRAINTS

As part of the survey referred to earlier, Jamrah et al. (2004) assessed Omanis' attitude towards treated greywater reuse. The survey revealed that: (a) 84 percent of the respondents were in favor of treating and reusing greywater; (b) 74 percent of the respondents felt that adoption of greywater treatment system would be financially beneficial; (c) 82 percent of the respondents felt that treated greywater could be used for irrigation; (d) 72 percent of the respondents felt that treated greywater could be used for toilet flushing; and (e) 42 percent said that it can be used to wash cars. However, 61 percent felt that treated greywater reuse may lead to environmental degradation and another 47 percent felt that it would be harmful to human health. Surprisingly, 16 percent responded favorably for treated greywater to be used for potable purposes. Those not in favor of treated greywater reuse cited religion, health, environmental degradation including groundwater contamination and costs as reasons.

Another survey (unpublished) conducted among 400 students of SQU found that 62.5 percent supported separating greywater from blackwater, 58.5 percent would use treated greywater at home and 43 percent would pay extra to change existing plumbing to facilitate greywater use. When asked for the main reasons for not accepting unlimited use of treated wastewater, 40 percent identified health and 37 percent identified religion as the reasons.

In spite of some Omanis' perception that the reuse of treated greywater is contrary to religious teachings, a council of leading Islamic scholars of Saudi Arabia issued a special fatwa in 1978 permitting the reuse of treated wastewater, even for ablution (*wudu*), provided that the wastewater is treated at the required level of purity for its intended use and did not result in any adverse public health effects (Faruqui et al. 2001). Furthermore, it has been repeatedly demonstrated that chlorination removes all biological pathogens from greywater. Therefore, it appears that a promotional campaign based on these facts may be necessary to address Omanis' religious and health concerns.

## FINANCIAL CONSTRAINTS

In Oman, like many other countries, household plumbing combines greywater and blackwater, thus requiring modifications to plumbing to separate them. Furthermore, the amount of greywater produced from individual households (approximately  $1 \text{ m}^3 \text{ d}^{-1}$ ) may not be financially attractive to consumers. It is recalled that the potable water is supplied at a subsidized price between \$1.14 – \$1.71 USD per cubic metre. This subsidy may be a disincentive for public to make the necessary investment in greywater treatment and reuse systems. Unless it is demonstrated that the cost of modification of existing plumbing and installation and management of the greywater treatment system can be recuperated in a realistic time period, only those who are environmentally motivated and with concern for a national cause would invest in greywater separation and treatment systems.

However, the separation, treatment and reuse of greywater *in situ* will reduce pressure on urban sewage systems and the cost of building them. The Government of Oman is now investing in new urban sewage systems in Muscat area, replacing septic tanks in houses. Hence, it may be appropriate to evaluate whether providing a subsidy to Omanis to separate, treat and reuse greywater *in situ* is more financially beneficial than investing in larger sewage systems to transport and treat all wastewater produced at households.

There is evidence of financial benefits of treating and reusing greywater elsewhere. Faruqui and Al-Jayyousi (2002) for example, found four household irrigation projects in Jordan using greywater to have benefit-cost ratios from 2.8 to 9.4. Therefore, greywater treatment and reuse for home vegetable gardens may be an attractive option for financially rational consumers. Booker (2000) demonstrated that the cost of reclaiming greywater is about 30 to 40 percent cheaper than supplying potable water to

houses in Melbourne, Australia. He argued that communal greywater treatments systems would be more economical than greywater treatment systems for single dwellings. His analysis excluded positive external factors such as reduced demand for potable water and reduced flow of sewage.

## **LEGAL CONSTRAINTS**

At present, Omani wastewater reuse standards do not distinguish between greywater and blackwater. They require that greywater be treated to the standards of potable water. However, there are many households and mosques in Oman (and in many other parts of the world) that use untreated greywater for home irrigation. In principle such uses are illegal, but the bottom line is that unrealistic laws have poor participation rates and are not easily enforceable. There is also a lack of evidence to suggest that such common illegal practice has done any harm to an individual or a society.

As the reuse of greywater is not widely practiced in water-starved Oman, there is no evidence of harm, yet there is also a lack of standard guidelines for greywater reuse. It may therefore be appropriate to develop legal standards, based on practicality, for this purpose. This may result in more lenient standards for greywater reuse than for blackwater reuse, thereby distinguishing between the two. In addressing these legal and regulatory aspects of wastewater management, the Government of Oman may like to consider those legal codes developed, revised and adopted by several states in the USA and in Australia as guides to develop a similar such one for Oman.

## **INSTITUTIONAL CONSTRAINTS**

Further to the legal and regulatory aspects of wastewater management, instigating a paradigm shift and implementing effective practices requires the partnership of an institution. We have seen how overseas experience, in particular in arid and semi-arid countries, indicates that greywater can be a cost effective alternative source of water that can be used to promote sustainable development and resource conservation without compromising public health and environmental quality. However, in spite of such apparent and tangible benefits, treated greywater reuse has not been widely adopted in Oman. There is a need to generate interest among public so that greywater reuse becomes a reality in Oman. This can be achieved if an institution in Oman, be it governmental or otherwise, champions and promotes treated greywater reuse based on facts instead of perceptions. It is appropriate to note here that treated greywater reuse in Jordan and Palestine is promoted by religious scholars (*Imams*) and perhaps a similar approach could be undertaken in Oman. To reap the benefits, the reuse of greywater must be more deeply institutionalize in Oman.

## **CONCLUSION**

When various constraints for treated greywater reuse are considered in totality, many of them are not insurmountable. In cases where low volumes of greywater are produced and the separation of greywater requires major modification to plumbing, it may not be prudent to invest in greywater treatment systems. However, it would be beneficial to individuals and to the nation of Oman if both society as a whole and the building industry in particular could be persuaded to install greywater treatment systems in (a) new houses, (b) new apartment complexes, and (c) public buildings such as mosques and schools, where existing plumbing may be easily modified to separate greywater from blackwater. The benefits would be higher still if the treated greywater can be used for irrigating fruits and vegetables. This would require an Omani institution to champion this cause and promote treated greywater reuse based on facts.



## ACKNOWLEDGEMENT

This research is funded by His Majesty's Fund for Strategic Research (SR/AGR/BIOR/03/01), administered by Sultan Qaboos University. The financial support of Sultan Qaboos University (SQU Research Projects: IG/AGR/SOIL/02/01) is gratefully acknowledged.

## REFERENCES

- Ahmed, M., S.A. Prathapar, A. Al-Belushi, A. Al-Busaidi and M. Al-Haddabi. 2003. 'Greywater Reuse Potential in Oman'. The Institution of Engineers, Australia. 28<sup>th</sup> International Hydrology and Water Resources Symposium. Wollongong, NSW, Australia.
- Booker, N. 2000. 'Economic scale of greywater reuse system'. [http://www.dbce.csiro.au/inno-web/1200/economic\\_scale.htm](http://www.dbce.csiro.au/inno-web/1200/economic_scale.htm)
- Dixon, A., D. Butler, A. Fewkes and M. Robinson. 1999. Measurement and Modeling of quality changes in stored untreated greywater. *Urban Water*. 1(4): 293-306.
- Faruqui, N.I., A.K. Biswas and M.J. Bino (Eds). 2001. *Water Management in Islam*. IDRC and U.N. University Press, Ottawa, Canada. 200 pp.
- Faruqui, N. and O. Al-Jayyousi. 2002. 'Greywater reuse in urban agriculture for poverty alleviation: A case study in Jordan'. *Water International*, 27(3): 387-394.
- Griggs, J.C. Shouler, M.C. & Hall, J. 1996. 'Water Conservation and the Built Environment. 21 AD: Water'. *Architectural Digest for the 21st Century*. School of Architecture, Oxford Brookes University.
- Jamrah, A., Al-Futaisi, S.A. Prathapar, M.Ahmad and Ali Al Harasi. 2004. 'Evaluating greywater reuse potential for sustainable water resources management in the Sultanate of Oman'. International Conference on Water Demand Management. Dead Sea, Jordan.
- Jeppesen, B. 1996. 'Domestic greywater re-use: Australia's challenge for the future'. *Desalination*. 106:311-315.
- NSW Health (Australian Government). 2000. 'Domestic greywater treatment systems accreditation guidelines', p.12.
- (Omani) Ministry of Housing, Energy and Water. 2002. 'Annual Report. 2002', p. 76.
- Prathapar, S.A., M Ahmed, S. Al Adawi, and S Al Sidiari. 2004. 'Variation in quality and quantity of greywater produced at two mosques in Oman'. International Wastewater Conference, Salalah, Oman.
- Sheikh, B. 1993. 'Water Management in the '90s: A Time for Innovation', Los Angeles grey water pilot project. Proceedings of the 20th Anniversary Conference. Seattle, Washington. Katherine Hon, Editor. American Society of Civil Engineers. P. 907.
- Stephenson, T. and Judd, S. 1998. 'In-Building Wastewater Treatment for Water Recycling: Final Report'. Cranfield University, p.9.
- Surendran, S. and A.D. Wheatley. 1998. 'Greywater Reclamation For Non-Potable Reuse'. *J. CIWEM*. 12: 406-413.

# DESALINATION PRIVATISATION IN THE SULTANATE OF OMAN CASE STUDY: BARKA POWER AND DESALINATION PLANT

Taher M. Ali Sajwani, Technical Expert, MHEW; Ahmed Al Subhi, AES Barka SAOC

Email: taher@omantel.net.om

## ABSTRACT

The Government of the Sultanate of Oman decided in 1999 to open up and privatize the whole electricity sector. This was considered part of Omani economic reforms that have taken place since the third and fourth five years plans instigated by the Government.

As part of the electricity privatization process, it was decided to fast-track the implementation of some projects to enhance the infrastructure of power supply, due to the high demand from new and existing customers. The Barka power and desalination plant was one of the projects approved by the government to be executed by the private sector during this period. It was the first dual purpose power generation and desalination plant, 100 percent owned by international and local investors. The capacity of the first phase of the plant is 427 MW and 20 MIGD.

This paper highlights some issues of privatization of desalination plants associated with power generation in Oman, for which the Barka power and desalination plant will be considered as a case study.

## INTRODUCTION

The history of major desalination plants in Oman goes back to early 1970s when it was decided by the government to build the Ghubrah power and desalination plant in the Governorate of Muscat, to meet the high demand for potable water for domestic purposes, due to the fast development of the country, population increase and rapid rise in living standards.

Today, five *Wilayats* out of six in Muscat depend mainly on desalinated water for their daily water supply in order to meet domestic, industrial and commercial demand. The installation capacity of the Ghubrah plant, which comprises of seven multi-stage flash units with associated steam and gas turbines units, is now 41 million imperial gallons per day (MIGD). The average daily production in 2003 reached 33 MIGD.

Until this year, the government of the Sultanate of Oman was responsible for the supply of electricity and potable water supply. Based on the (international and local) experience of the Manah Power station in the mid nineties, and the outcome of the study, "Oman Electricity and Related Water Sector Privatisation" in 1999, it was decided by the Cabinet to open up and privatise the electricity and related water sector. The study recommended that before the process take place, certain fast-track projects should be executed to strengthen the infrastructure of the power and water supply. The Barka Power and Desalination Plant was one of these such recommended projects that was chosen to be implemented by the private sector on a Build, Operate and Own (BOO) basis, for 15 years from the commercial operation date (COD). It was decided to start plant construction in 2000, to be completed by 2003.

# **BARKA POWER AND DESALINATION PLANT**

## **Background**

The project tender was floated by the Tender Board on 30/04/2000 and bids by three international bidders were received on September 4<sup>th</sup>, 2000. The successful bidder, AES BARKA of USA and its local partner Multitech signed the contract document on November 26<sup>th</sup>, 2000 and the Commercial Operation Date was set on April 4<sup>th</sup>, 2003. The main plant contents, agreements, environmental and other contractual requirements are listed below.

## **Main Plant Contents**

- Three MSF units (each 6.7 MIGD), No. of stages 16 heat recovery +3 heat rejection.
- Two Gas Turbine each rated at 117 MW with generator 159 MVA each at reference condition of 50 °C and 100% humidity.
- One Steam Turbine rated at 222 MW with generator 280 MVA.
- Fuel Facilities (Natural Gas and Fuel Oil as supplementary).
- Two heat recovery steam generator (HRSG), with supplementary firing, including demineralisation water treatment for boiler.
- Sea Water Intake and out –fall facilities for phase (I) and (II) (Four sea water embedded pipes, length of the pipes is 1200m and diameter 2.2m for intake and 2.5m for outfall).
- Control and administration building.
- All ancillary facilities (transformers, switchgear, fire fighting facilities, etc).
- Remineralisation plant (CO<sub>2</sub>, limestone, chlorination, fluoridation, etc).
- Roads, Security fence and system,

## **Main Agreements.**

- Power and Water Purchase Agreement (PWPA).
- Natural Gas Sales Agreement (NGSA).
- Usufruct Agreement (land lease).
- Master Novation Agreement.
- Founders Agreement.
- Performance Bond.
- Omani Contents and Omanisation.

## **Environmental Requirements**

An Environmental Impact Assessment (EIA) study was undertaken and the results of the study were better than the parameters mentioned in the Agreement.

The fuel for Barka plant is natural gas which has low Sulphur content of 5 ppm or less. The main by-product of the combustion is water vapour, carbon dioxide (CO<sub>2</sub>) with the limit of 40 mg/nm<sup>3</sup>, and oxides of nitrogen (NO<sub>x</sub>) with the limit of 60 mg/nm<sup>3</sup>. The Sulphur dioxide (SO<sub>2</sub>) and particulate (smoke) associated with coal or oil produced other than in trace amounts.

Plant emission and noise levels are controlled to meet the requirement of Ministry of Regional Municipalities, Environment and Water resources and World Bank Guidelines. Using Dry low NO<sub>x</sub> (DLN) combustion significantly reduces the NO<sub>x</sub>, which is the main environmental concern in the gas-fired plant. NO<sub>x</sub> levels during plant performance testing have been well below the required levels.

Clean water after treatment has been used inside the plant for landscaping. The seawater outfall has been designed to minimize the thermal effect of the circulated seawater that is returned to the marine environment.

## **Tariff**

Usually the tariff of an IP (W) P is divided into two sections, namely the capacity charge and the energy/water output charge. The capacity charge consists of an investment charge and a fixed operation and maintenance charge. Adjustments are made toward scheduled unavailability of the plant and/or units, forced outage and de-rating of the plant. The calculation formulae also take into account the inflation and exchange rates. The energy/water output charge consists of a fuel charge, variable operation and maintenance charge and number of start-ups of the units above those offered by the project company.

## **Why Privatised Desalination plants**

Recently in the Gulf countries, the trend has shifted responsibility for implementation of desalination plant projects from governments to the private sector. This could be attributed to the following factors:

- Desalination projects need significant capital and their operation expenditures can affect the civic budgets and thereby influence government spending on other priorities. Governments call for public/private partnership, to help share these costs and responsibility.
- Due to higher comparative costs of production for ground and natural water, high subsidies are required. The private sector focuses on the subsidies and makes efforts to reduce them with higher technical, operational and financial efficiencies and performance.
- Large sums of foreign and local investment for a longer time can be attracted.
- The desalination industry can be regulated with proper contractual obligations and duties. This would guarantee security of supply, particularly by the private sector.
- Capital markets can be stimulated with new capital and participants.
- The project implementation period can be shortened by the private as compared to public sector and the plant lifetime can be lengthened due to higher quality maintenance available privately.
- The technology of desalination is closely associated with electricity, underlining the importance of efficiency and performance of the plants.

## **CONCLUSION**

Desalination is partly a solution to water shortage problems in water scarce countries such as those in the Gulf. It comprises is a significant yet vital part of economy in Oman. However, due to higher costs of desalination compared to natural water, subsidies are required. The private sector is therefore encouraged to participate in building, operating and owning desalination projects. Local and international investors have a readiness to invest in the desalination business and in general, it is important to accumulate local experience in the field of desalination operations, manufacturing, research and development, projects execution, etc. Several sectors can benefit from the privatisation of desalination plants, such as capital markets, local trade, manufacturers, contractors, investors etc. However, regulation is necessary and performance, efficiencies, timing, quality control, etc could be enhanced through better conditions of contracts. Thus, it is important to spread awareness about privatisation, and especially as relates to desalination, to the public.

# DECENTRALIZED WASTEWATER USE FOR URBAN AGRICULTURE IN PERI-URBAN AREAS: AN IMMINENT OPTION FOR THE ORGANISATION OF ISLAMIC CONFERENCE COUNTRIES

Al-Beirut, Shihab N. Head of Services and Programs Section, Inter-Islamic Network on Water Resources Development and Management, Amman, Jordan. E-mail: [shihabinw@nic.net.jo](mailto:shihabinw@nic.net.jo)

## ABSTRACT

This paper concentrates on the experience, methods and results of the Inter-Islamic Network on Water Resources Development and Management (INWRDAM) in greywater treatment and use, in order to make it easily affordable to more Islamic countries.

Over the last five years the INWRDAM has undertaken applied research on decentralized wastewater treatment and use. This has focused on instigating a holistic approach for the development of “state of the art” modular on-site greywater treatment and use units at the INWRDAM household level, and implementing capacity building of the local peri-urban communities to enable them to practice sustainable urban agriculture (UA) by saving fresh water and safeguarding the environment. The outcome of this research to date has been the optimization of the modular low-cost units for greywater treatment and use by drip irrigation techniques and selection of crops for home gardens.

These findings were the results of three projects. The first, entitled ‘Post Project Evaluation of Permaculture Techniques’, and second, entitled ‘Greywater Treatment and Reuse in Home Gardens’, were both conducted in the town of Ein Al-Baida, Tafila Governorate, in the southern part of Jordan, and were funded by research grants from the International Development Research Centre, Ottawa, Canada (IDRC). The third project, entitled ‘Community Involvement in Reuse of Greywater to Improve Agriculture Output’, was financed by the Jordanian Ministry of Planning and International Cooperation of Jordan (MOPIC), and benefited more than 800 households in 90 peri-urban sites throughout Jordan with greywater units and drip irrigation systems. The INWRDAM also succeeded in establishing similar greywater activities in other Islamic countries such as Lebanon, where the adoption of greywater in a cluster of six towns is being implemented. The results of this research were well-accepted by the local community and by the government of Jordan. More projects addressing greywater use are now being implemented in Jordan, Palestine and Lebanon, with emphasis on conserving fresh water, improving sanitation and generating extra income for the poor in peri-urban areas. They constitute sustainable urban agriculture practices. As a result of these activities, a recent evaluation of INWRDAM’s greywater projects indicated that ‘INWRDAM has contributed to raising the profile of greywater use both in Jordan and in other parts of the world’.

## INTRODUCTION

Freshwater is a finite, naturally renewable resource received by way of precipitation, but significantly, is unevenly distributed in time and space. In 1989, Falkenmark, Lundqvist and Widstrand ranked countries according to “per capita annual water resources”. For annual water resources of 1700 m<sup>3</sup> and above, shortage will be local and rare; for 1000 m<sup>3</sup> and below, it will hamper health, economic development, and well being; and for 500 m<sup>3</sup> and below, water availability will be a primary constraint to life (3). Since 1995, the INWRDAM published water scarcity data on 55 Muslim countries, revealing that most of these countries have water availability of less than 1000 m<sup>3</sup> and 10 countries out of the total, including Jordan, have per capita water of less than 500 m<sup>3</sup>.

Centralized sewerage systems, the preferred choice for planners and decision makers, are inappropriately provided to individual communities and wastewater is transported from several scattered communities to centralized facilities. The high cost of conventional sewers is regarded as one of the major constraints to expanding wastewater services to small communities. A World Bank review of sewerage investment in eight capital cities in developing countries found that costs range between US \$600 to \$4000 per capita (1980 prices), with total household annual cost of US\$ 150 to 650 (2). The conventional sewerage systems are more costly in small communities: because of their size and layout, small communities do not enjoy the economies of scale needed for building large systems. The low population density means that longer sewers are needed to serve each household. The cost per household in the Jordan Valley rural sanitation project was projected at US\$2200, four times the average of all urban wastewater projects constructed in Jordan between 1997 and 1996 (4).

Conventional sewerage systems are designed as waste transportation systems in which water is used as a transportation medium. Reliable water supply and consumption of 100 litres per capita per day (lpcd) are basic requirements for the problem-free operation of conventional sewerage systems. Conventional sewerage is not appropriate for small communities in the Middle East region where water supplies are intermittent and only limited amounts of water are available. By transporting the wastewater away from the generating community, several reuse opportunities can be lost. Reuse opportunities are often located within the generating community for landscape or for agriculture. Recent research and development in the field of greywater and wastewater management suggests that centralized wastewater management is environmentally unsustainable (5).

## **GREYWATER USE**

A functional and sustainable wastewater management scheme begins at the household level and is largely dependant on the “software” or human component of the process. Only when perception of need and perhaps also the anticipation of a wastewater use system has been internalised at the neighbourhood/ user level, will planning and implementation be successfully executed (6). Local-level support of a treatment and recovery scheme can, in turn, catalyse pro-active institutional and vertical support from the government. Once the software component has been integrated into the project development, the “hardware” or technological component can act to promote a comprehensive, integrated, and sustainable wastewater treatment and recovery strategy for the community - if it is well selected and “appropriate”. Wastewater and greywater treatment technologies in the developing world must have one overriding criterion: the technology must be cost-effective and appropriate.

Greywater use represents the largest potential source of water-saving in domestic uses. The use of domestic greywater for landscape irrigation makes a significant contribution towards the reduction of potable water use. In Arizona, for example, it is documented that an average household can generate about 135,000 to 180,000 litres of greywater per year (7). This illustrates the immense potential amounts of water that can be used, especially in arid regions like the Middle East and North Africa. Domestic greywater use offers an attractive option in arid- and semi-arid regions due to severe water scarcity, rainfall fluctuations, and the rise in water pollution. To ensure sustainable water management, it is crucial to move towards the goal of efficient and appropriate water use. Greywater use contributes to promoting the preservation of high-quality fresh water as well as reducing pollutants in the environment. Meeting different needs with the appropriate quality of water may prove to be economically beneficial and at the same time reduce the need for new water supplies at a higher marginal cost (7/8).

## **HEALTH GUIDELINES**

Wastewater treatment must meet quality standards safe for human contact, use and consumption and for application to irrigated crops. In most countries, guidelines and standards for greywater either do not exist or are being revised or expanded. The most frequent guidelines directing the use of greywater to a level considered safe enough to protect human health are those outlined in the Engelberg Standards. These guidelines outline acceptable microbial pathogen levels for treated wastewater for use in restricted and non-restricted irrigation. Restricted irrigation refers to the irrigation of crops not directly consumed by humans (e.g. olive trees, fodder crops). For restricted irrigation, wastewater effluents must contain  $\leq 1$  viable intestinal nematode egg per litre. Unrestricted irrigation refers to the irrigation of vegetable crops eaten directly by humans, including those eaten raw, and also to the irrigation of sports fields, public parks, hotel lawns, and tourist areas. The criteria for unrestricted irrigation, contains the same helminth criteria as restricted irrigation, in addition to a restriction of no more than a geometric mean concentration of  $\leq 1000$  faecal coliforms per 100 ml/treated effluent. These guidelines have been introduced to directly protect the health of consumers who may eat uncooked crops, such as vegetables and salads (9).

## **GREYWATER TREATMENT PROCESSES**

The daily quantity of greywater collected or recovered from a household in rural areas is usually small. The major difficulty presented for treatment of greywater is the large variation in its composition. For instance, laundry effluents contain high concentrations of detergents and washed out dirt, and this can double or even treble the organic content of the greywater. Cooking and frying oil and fat in the form of food that remains on dishes and in cooking utensils, results in the biggest source of organic pollution in greywater recovered from an average family house.

Treatment of greywater to a quality level suitable for irrigation of home garden crops not eaten raw can be achieved by a variety of methods, but low cost and low technology must be the main factors in selecting a treatment method. Anaerobic treatment systems, such as up-flow anaerobic sludge blanket or the confined space constructed wetland offer reasonable choices for greywater treatment. Anaerobic treatment processes are not affected by wide variation in influent quality or shock loads as compared to aerobic processes.

The main pollution load in greywater is in the form of organic matter and pathogenic micro organisms. Greywater can contain about  $10^5/100$  ml of potentially pathogenic micro organisms. Stored greywater undergoes changes in quality, which include growth in numbers of micro organisms according to the limiting factors for each particular micro organism. Research has shown that counts of total coliforms increased from  $10^0$ - $10^5/100$  ml to above  $10^5/100$  ml within 48 hours in stored greywater from various sources. Of more concern is the potential infection route that greywater provides for viral infections. It is important that the nutrient resources (nitrogen and phosphorous) be conserved if the wastewater is destined for use in agriculture irrigation. Greywater use in irrigating home gardens in rural areas offers higher potential success and public acceptance.

## **CHARACTERIZATION OF GREYWATER**

The quality of greywater is directly related to the amount of water used in the house. It is affected by certain habits of the occupants such as bathing, the use of disposable or washable diapers and baby washing, and whether dishwashing is undertaken by hand or with a dishwashing machine. The flush toilet consumes much more water than the non-flush type commonly used by the rural poor in developing countries, and in much of the Middle East. Highly urbanized and high-income families use

much more domestic water than the rural poor. The kitchen is a major source of pollutants in greywater and cloths washing and laundry may come next. Some countries enforce regulations that prevent mixing greywater originating from the kitchen sink with greywater from other sources in the house. The use of soaps and body shampoos and excess use of detergents and cleansing chemicals can in general significantly increase the pollution of greywater.

Greywater is relatively low in suspended solids and turbidity, indicating that a greater proportion of the contaminants is dissolved. The COD:BOD ratio may be as high as 4:1 (much higher than values reported for sewage) and this is mainly due to use of detergents of low biodegradability. COD values could vary from 40 to 370 mg/l between sites, with similar variations arising at an individual site. Greywater is also deficient in macronutrients such as nitrogen and phosphorous (10).

## INWRDAM EXPERIENCE IN GREYWATER TREATMENT AND USE

From 2001 to 2003, the International Development Research Centre (IDRC), Ottawa, Canada provided INWRDAM with financial assistance to enable it to conduct an applied research project for greywater treatment and use in irrigation of home gardens in Ein Al Beida village, Tafila Governorate in southern Jordan. The main objective of the research was *“to help the periurban poor in Jordan preserve precious fresh water, achieve food security, and generate income, while helping to protect the environment”*.

To achieve this goal, the following specific objectives set for this project were to:

- increase greywater recovery and make it more convenient and safe to handle;
- minimize environmental impacts associated with greywater use and ascertain whether greywater treatment is necessary and cost-effective;
- improve gardening/permaculture practices;
- strengthen local capacity to safely and efficiently use greywater and enable women to be better managers of household resources;
- promote changes in policies to encourage greater greywater use in Jordan.

Baseline data was collected about domestic water consumption, greywater quality, and the type of crops grown in the area and willingness of households to participate in use of greywater. This research project targeted 25 low-income households, including a girls’ high school and the main mosque as beneficiaries of the project. The average family size was 6.2 persons/ household and domestic water consumption was on the average about 120 lpcd, which is a little high for a rural area, but the reason may be due to the use of fresh water in irrigation of home gardens and in watering livestock. Table (1) shows typical greywater quantities from different sources in the house.

Table 1. Average daily water uses in house in rural areas in Jordan (11)

Sources	lpcd
Intake and cooking	10
Kitchen, hand dishwashing	15
Bath/shower	20
Laundry	20
Toilet, non flush	15
Miscellaneous and irrigation)	40
Total	120

The baseline data in Ein Al Baida, Tafila revealed the following:



- The average BOD<sub>5</sub> of raw greywater ranged from 300 mg/l to 1200 mg/l due to low water consumption and because the kitchen sinks were considered as a source of recovered greywater.
- The detergent concentration in greywater, measured by the methylene blue active substances (MBAS), and ranged from 10 mg/l to 300 mg/l.
- Salinity of greywater was on average equal to 820 µS/cm, which nearly doubled from the 450 µS/cm value for domestic water supply.
- The average background soils salinity; measured as sodium adsorption ratio (SAR) was about two.
- The main crop in home gardens was olive trees and most families preferred to raise chicken and goats.
- Most households had no religious or cultural barriers precluding the use of wastewater and women showed a willingness and ability to learn new methods of irrigation and home gardening.

Women leaders in the village community were identified and trained to be trainers of other women and girls on various subjects, such as upstream pollution prevention in the house by wise use of detergents, good dishwashing practices and permaculture techniques. Local technicians were trained to carry out the operation and maintenance of greywater treatment units.

### **Description of technology**

On-site greywater treatment methods developed by INWRDAM were designed to minimize costs, maximize the ease of construction, lower operation and maintenance costs and yield greywater of a quality suitable at least for restricted irrigation.

#### **The two-barrel system**

Two plastic barrels constitute the treatment kit, each with a capacity volume of 160 litres, and a large cover, which can be closed tightly. The two barrels are lined up beside each other and interconnected with 50 mm PVC pipes. The first barrel or tank is fitted with pipes to allow grease, oil and solids to separate, and thus acts as a pre-treatment or primary treatment chamber, where the solid matter in the influent greywater settles and other components, such as grease and soap foam, float. When the cover is opened, the chamber can be cleared of both floating and settled material. The second barrel or tank acts as a storage tank for primarily greywater. As soon as this barrel is filled, a floating device switches on a small water pump which then delivers the water through the drip irrigation network. The two-barrel kit was found suitable for small families such as pensioners and old couples with no kids.

#### **The four-barrel system**

This system is an improvement on the two barrel kit. Two tanks each with a 220 litre capacity are filled with gravel that act as anaerobic filters, which are inserted between the pretreatment tank and final storage tanks. The four barrels are lined up next to each other and interconnected with 50 mm PVC pipes.

Once solids and floating material settle in the first barrel, the relatively clear water from the first barrel enters into the bottom of the second barrel. Next, the water from the top of the second barrel enters into the bottom of the third barrel. This water passes through the gravel lumps (2-3 cm size graded gravel) and from the top of the third barrel is taken into the fourth. Anaerobic treatment is accomplished in the two middle barrels. Anaerobic bacteria gets established on the stone surface so that when the greywater passes through the stones, the bacteria works on breaking down components of the organic material found in the greywater. The last barrel acts as a storage tank for treated

greywater. As soon as this barrel is filled, a floating device switches on a small water pump which then delivers the water through the drip irrigation network. For an average family home, 20-30 trees (olives, fruit etc) that are planted in the domestic garden can be irrigated.

With the resident time of one to two days in the four-barrel treatment kit, the influent greywater undergoes a treatment level that meets the World Health Organization's guidelines for *restricted* irrigation, specifically equivalent to a level between primary and secondary treatment.

### The confined trench system

Two plastic barrels and a dug trench filled with gravel media constitute the confined trench system. The first barrel functions as a grease, oil and solids separator and thus acts as a pretreatment or primary treatment chamber, where the solid matter from the influent greywater settles and the floating components, such as grease and soap foam floats, and can be removed regularly. A trench, approximately three metres long, 1 metre wide and 1 metre deep, is dug close to the first barrel and is lined with an impermeable polyethylene sheet of 400-500 µm thickness. The trench is then filled with 2 to 3 cm size graded gravel. Pretreated wastewater from the first barrel enters the bottom part of the trench from one side and flows slowly to the other end. The sides of the side trench are plastered with a mud layer so that the liner sheet is not punctured by sharp stones. A 120 litre capacity plastic barrel is perforated and buried in the gravel at each end of the trench so that treated wastewater flows throughout the trench and upwards to fill this barrel. As soon as this barrel is filled, a floating device switches on a small water pump which then delivers the water through the drip irrigation network. Residence time of greywater in the trench is two to three days under anaerobic conditions. The confined trench unit can serve more than one nearby family sharing same garden plot, and can also deliver more water quantity between pumping cycles.

Tables 2A, 2B and 2C (below) show the quality of a representative raw greywater in rural areas of Jordan and the effluent quality of treated greywater that can be used to irrigate productive home gardens.

Table 2 A. Effluent quality from 2- barrel system (households No 1)

Sample type	pH	TSS	O&G	BOD5	ABS
11-6-02	6.4	39	24	154	19
21-7-02	6.7	69	21	186	60
14-8-02	7.8	2	14	23	1
05-9-02	8.3	57	NT <sup>a</sup>	59	2
20-10-02	6.1	94	30	518	NT
13-12-02	8	19	96	12	NT

<sup>a</sup>NT= Not tested

Table 2 B. Effluent quality from 4- barrel system (households No 6)

Sample type	pH	TSS	O&G	BOD5	ABS
11-6-02	6.8	183	31	844	110
14-8-02	4.7	165	7	564	95
14-12-02	6.3	76	44	369	NT
17-02-03	7.4	128	40	246	170
29-05-03	8.2	88	NT	225	NT

<sup>a</sup>NT= Not tested

Table 2 C. Effluent quality from confined trench (households No 3)

Sample type	pH	TSS	BOD5	COD
07-07-03	7.7	398	467	327
03-08-03	7.2	22	14	87
06-09-03	7.6	48	32	198

The greywater quality parameters, shown in the tables above, demonstrate the degree of effectiveness of the treatment of greywater. The variation in greywater quality was substantial and was affected by the care of family members with respect to up stream prevention of pollution. The regular cleaning of the oil and grease separator barrel resulted in big improvements in treatment and reduction of coliform counts.

The greywater of these units were fit for irrigating olive trees, cactus and many fodder crops. Monitoring of the impact of greywater on soil and plants after two years of application revealed some increase in soils SAR, but it was below a level that could affect plant yield. All plant growth rates were improved due to regular complementary irrigation and there was no contamination of crops with fecal coliform.

During this project, the INWRDAM developed a special environmentally-friendly liquid dishwashing detergent and bathing shampoo that contain potassium or magnesium ions in place of some sodium ions, so that the long-term impact of detergents is controlled. The long-term impact of greywater application on soil and plants was also addressed and available data monitored over two years indicate that no build-up of harmful salinity and harmful chemicals was recorded.

The cost of the kit module that serves a family of six, including a drip irrigations system for 2000 m<sup>2</sup> garden area, was around US\$ 230, whereas the two-barrel kit and four-barrel module was US\$ 370, and the confined trench serves up to 12 persons was US\$ 500, including drip irrigation systems. A cost/benefit analysis indicates that the household's income increases thanks to greywater irrigation, saving fresh water costs, a reduced septic tank disposal cost and improved crop yield. This saving is in the range of 10 to 30 Jordanian Dinar (JD) per month. This means that cost of greywater units can be recovered on the average in less than three years. The life of the greywater units is estimated to be more than 10 years with minimal running cost.

## **INWRDAM's Phase II of the Greywater Project**

INWRDAM conducted Phase I of this IDRC-funded project from May 2001 to May 2003 in Tafila Governorate, southern Jordan. During Phase I, INWRDAM installed 25 greywater units in low income households of the periurban community of Ein Al-Baida, a town in Tafila. Five different types of on-site greywater treatment units/modules were developed and tested over three years. Two out of the five modules were selected as potential units for further improvement. One module is known as the four-barrel unit (see Figure 1), which consists of four recycled plastic barrels lined up in an arrangement to receive greywater and achieve physical and biological treatment. A small automatic electric pump is used to deliver treated greywater to a trickle irrigation system serving a small garden of trees. The second unit (see Figure 2) is known as the Confined Trench (CT) module. It consists of a stage for removal of oil and grease, as well as a dug trench of about 3.5 m<sup>3</sup> filled with gravel that serves as the treatment medium. The treated greywater is then pumped automatically through a trickle irrigation system. In addition to units installed in Ein Al-Baida, INWRDAM has also installed over 750 greywater units of different types for the benefit of low income families across Jordan in 2002, through a project financed by the Jordanian Ministry of Planning and International Cooperation (MOPIC).

Phase II will construct 300 additional greywater systems for low income families in clusters of towns in selected periurban areas, so as to further improve technical aspects, remove social and institutional obstacles and build momentum, thus accelerating the adoption of the greywater system in Jordan and elsewhere in the region. A key component of the project will be to promote community participation in all stages of the project by adopting participatory methodology. Phase II will involve cooperation between concerned agencies in wastewater use, social development, building codes and public health. The National Centre for Agriculture Research and Technology Transfer (NCARTT) will be involved in the environmental and agricultural research components of this project.

The Phase II Goal is: “To help the peri-urban poor in Jordan preserve precious fresh water, achieve food security, and generate income, while helping to protect the environment”. The Phase II Objective is: “To evaluate previous greywater use projects in Jordan, validate existing approaches, address social and institutional obstacles to scaling up greywater use, and monitor and refine systems to ensure long-term sustainability”. The implementing organizations of Phase II look forward to cooperation amongst all stakeholders to ensure a successful outcome of this applied research project.

Figure 1. Four-Barrel Greywater Treatment Unit



## CONCLUSIONS AND RECOMMENDATIONS

The project resulted in many direct and indirect benefits to the community and the environment. Women in the community benefited most from this project through training workshops, dialogue and learning by doing - acquiring new management skills and learning to build a productive garden. The monthly domestic water consumption decreased by about 30 percent for all greywater users and income of the poor increased on the average by US\$50 to US\$150 per month. Many beneficiaries no longer had to pay a large portion of their meager monthly income to regularly emptying their septic tanks, thus many families started to copy and imitate the practice of their neighbors with respect to greywater use.

The following recommendations can be made regarding greywater use technologies:

- The scheme or technology should be a recognised priority in public or environmental health, and both centralized or de-centralized technologies should be considered.
- The technology should be low-cost and require low energy input and mechanization, which reduces the risk of malfunction.
- The technology should be simple to operate, be local-labor intensive, maintained by the community, and not rely on expensive chemical inputs, such as chlorine or ozone to meet quality guidelines.
- The treatment should be capable of being incrementally upgraded as user demand or quality standards and treatment guidelines increase.

The results of this project convinced the Ministry of Planning and International Cooperation of Government of Jordan that greywater use can preserve fresh domestic water, help improve agriculture productivity at household level and generate income. As a consequence of these tangible benefits, the Ministry of Planning of Jordan funded INWRDAM in September 2002 to enable the implementation of more than 700 greywater units in rural areas of Jordan. This project was successfully completed on June 2003. IDRC has approved in February 2004 a grant worth of CAD\$725,000.- for INWRDAM to further test and develop the greywater kits so that communities can be served with 300 of such kits over the coming 3 and half years in Jordan.

## REFERENCES

- 1 - Kalkenmark, M., Lundqvist, J. Widstrand, C. 1989. 'Macro-Scale Water Scarcity'.
- 2 - Requires Micro-Scale Approaches. 'Aspects of Vulnerability in Semi-arid Development'. *Natural Resources Forum*, 13 (4), 258-267.
- 3 - Chandrant D. Thatte (2002). 'Water and Food Security – How the Poor Will Get Their Food?'. *Water Resources Management; Crosscutting Issues*, I. H. Oclay Unver and Rajiv K. Gupta (eds). Middle East Technical University Development Foundation Publishing and Communications Co., Ankara.
- 4 - Mara, D. 1996. 'Unconventional Sewerage Systems: Their Role in Low-cost Urban Sanitation'. *Low-Cost Sewerage* (D. Mara, ed), pp. 13-18. Chichester: John Wiley and Sons.
- 5 - Loreda, D. and Thompson R. 1998. 'Assessment of Jordan Valley Rural Sanitation Feasibility Study', Environmental Health Project (EHP) Activity Report No. 44. Washington DC: USAID.
- 6 - Hedberg T. 1999. 'Attitudes of Traditional and Alternative Sustainable Sanitary Systems'. *Water Science and Technology*. 39 (5) 9-16.
- 7 - Khouri, N., Kalbermatten, J. M., and Bartone, C. 1994. 'The reuse of wastewater in agriculture: A guide for planners'. Washington, DC: UNDP/World Bank Water and Sanitation Program.
- 8 - Website: <http://www.watercasa.org/pub/graywater-guidelines.html>.
- 9 - Odeh R. Al-Jayyousi. 'Greywater reuse: towards sustainable water management', *Desalination*. 156 (2003) 181-192.
- 10 -Mara, D. and Cairncross, S. 1989. 'Guidelines for safe use of wastewater and excreta in agriculture and aquaculture'. Geneva: United Nations Environmental Programme/World Health Organization.
- 11 - B. Jefferson, A. Laine, S. Parsons, T. Stephenson and S. Judd. 1990. 'Technologies for domestic wastewater recycling'. *Urban Water*, 1: 285-292.
- 12 -Bino, J. Murad and Al-Beirut, S. 'Greywater Treatment And Reuse Project, Tafila, Jordan (2000-2003)'. Conducted by the Inter-Islamic Network on Water Resources Development and Management with financial support from the International Development Research Centre (IDRC).

# USE OF PYROAURITE TYPE SORBENT, ACTIVATED CARBON AND FLYASH IN REDUCING COD OF DOMESTIC WASTEWATER

Dr R.P. Singh, Piyush Gupta, Namrata Gupta and Radha Gupta; School of Chemical Sciences, Chemistry Department, St. John's College, Agra; E-mail: rp17\_in@yahoo.com

## ABSTRACT

The aim of the research was to evaluate the ability of a synthesized pyroaurite type sorbent (PTS) as an alternative media over activated carbon (AC) and flyash (FA) for domestic wastewater treatment.

The main components of domestic wastewater are proteins, carbohydrates, detergents, tannins, lignin, humic acid, fulvic acid, melanic acid and many other dissolved organic compounds that cause high values of chemical oxygen demand (COD).

Batch tests were carried out to reduce COD at different initial COD values, treatment times, adsorbent doses and pH values of the media. The results have indicated that the COD can be reduced by up to 90 percent by PTS or AC, while the use of flyash only reduces COD up to about 60 percent. The trend of COD removal percentage by PTS is fairly comparable to that of commercial activated carbon.

Though the capacity of FA is lower than that of PTS or AC, its low material cost makes it an attractive option for the treatment of domestic wastewater. Thus, the treatment of domestic wastewater can be done not only by PTS or AC, but also by flyash generated from a thermal power plant, or any factory, to reduce the organic load.

## INTRODUCTION

Water pollution by organic and inorganic chemicals is of serious environmental concern and wastewater is one type of polluted water that results from human use, be it domestic or industrial.

Domestic wastewater differs in its characteristics from industrial wastewater. In domestic wastewater the organic load mainly results from processes like bathing, sewage, food processing, and washing the floor, clothes, utensils and animals. The main components of domestic wastewater are proteins, carbohydrates, detergents, tannins, lignin, humic acid, fulvic acid, melanic acid and many other dissolved organic compounds (Manka et al., 1974). The organic content of wastewater is traditionally measured using lumped parameters such as biochemical oxygen demand (BOD), chemical oxygen demand (COD) and total organic carbon (TOC).

Commercial activated carbon is regarded as the most effective material for controlling the organic load. However, due to its high cost, and the fact that about 10 to 15 percent is lost during regeneration, unconventional adsorbents like flyash, peat, lignite, bagasse pith, wood and saw dust have been widely investigated for the removal of refractory materials (Pandey et al., 1985), with varying degree of success. Several investigations (Mott and Weber, 1992; Viraraghavan and Dronamraju, 1992) explored the use of flyash as an adsorbent for the treatment of wastewater to remove a variety of organic compounds and color. Gupta et al. (1990) used flyash for the removal of chrome dye from aqueous solutions and found that the mixture of flyash and coal (1:1) may substitute the activated carbon. Each of them concluded that flyash has a significant capacity for adsorption of organic compounds from aqueous solutions. It was reported that the carbon content of flyash plays a significant role during the adsorption of organic compounds by flyash (Banerjee et al., 1995). The adsorption capacity increases with the increasing carbon content of flyash. However, a review of the literature showed that very little investigation has been conducted to find out the suitability of synthetic sorbents like PTS or flyash for the removal of COD from domestic wastewater.

The aim of this research was therefore to evaluate the ability of a synthesized pyroaurite type sorbent (PTS) as an alternative media over activated carbon (AC) and flyash (FA) for water treatment. The research is likely to lead to the commercial development and modification of self synthesized pyroaurite -type sorbent for water treatment, with the following perceived benefits: aluminium (Al) free, multipurpose, low cost and rapid sorption medium.

## **TOXICITY OF ALUMINIUM**

Recently, aluminium exposure has been hypothesized as a risk factor for the development or acceleration of the onset of neuro-degenerative disorders such as Alzheimers disease and encephalopathia in humans. The so-called biologically inert Al has cumulative effects and it has been reported to cause dementia (Lopez et al., 2000). It can also cause brain damage, bone disease and anaemia in patients subjected to haemodialysis using water containing 0.1-1 ppm Al, which is the normal dose of Al (DL = 0.03 mg/l and MPL = 0.20 ppm) in drinking water, where aluminium is used in water treatment plants. Exploring and/or developing lower risk agents with high performance in the water treatment is therefore important, so as to avoid such levels of aluminium (Al) that can have detrimental effects on human health.

## **REASON FOR SYNTHESIZING PYROAURITE TYPE SORBENT**

Conventional sorbents face numerous shortcomings, summarised below, which constitute the principal reasons for synthesizing pyroaurite type sorbent:

- Activated carbon is an ideal adsorbent for organics but has high production and regeneration costs
- Flyash has a significant capacity for absorption of organic compounds from aqueous solutions. The carbon content of flyash plays a significant role during the absorption of organic compounds. Flyash has a low sorption capacity and cannot be used directly in column without modification.
- Conventional sorbents cannot remove contaminants rapidly from very dilute solutions (Köci et al., 2004).
- The use of microbes for water treatment is an attractive technique but unsuitable for applications on a large scale.
- Advanced treatment processes such as ion exchange, reverse osmosis, membrane separation, electrodialysis, chemical precipitation are very expensive.
- Pyroaurite-type sorbent is expected to have double layer hydroxides, oxides and other functional intercalating carbonate ion in their inner layers (Seida et al., 2001). Functionalisation can enhance its sorptive properties for specific needs.

## **MATERIALS AND METHODS**

Domestic wastewater samples were collected from a drain near St. John's Crossing of Agra city. The pH and EC of the samples were measured on site and the other parameters were analysed in the lab according to the APHA (1998). Samples were stored at a temperature below 4°C to avoid any change in the physico-chemical characteristics. The COD of the samples was estimated by dichromate oxidation before and after the sorption of contaminants with sorbents.

A pyroaurite-like compound (PLC) was synthesized from  $MgCl_2$  and  $FeCl_3$  by following the method reported (Seida et al., 2001). PLC was modified to obtain PTS. The modification was made by treating PLC with cetyltrimethyl ammonium bromide and dodecan-1-thiol.

Flyash was obtained from the Faridabad thermal power plant, Haryana. The flyash was derived out of the bituminous coal obtained from the Siyal and Gaddi coal mines of Bihar (India). The sample received was washed with distilled water to remove surface dust and was dried in the sun. Flyash samples were stored in the laboratory in an airtight plastic container. The physico-chemical characterisation of flyash was carried out using standard procedures. In addition, physical properties such as density and surface area were also determined. The major components of flyash are: alumina, silica, iron oxide, calcium oxide and residual carbon. However, the constituents of flyash vary according to the type of coal used and degree of combustion. In this case, granular activated carbon was procured from CDH, India.

The batch experiments were run in different glass flasks of 250 ml capacity, using a shaker at an average speed of 150 repetitions per minute (rpm). Prior to each experiment, a predetermined amount of adsorbent was added to each flask. The stirring was kept constant for each run throughout the experiment, ensuring equal mixing. The desired pH was maintained using dilute NaOH/HCl solutions. Each flask was filled with a known volume of the sample, with the desired pH, to commence the stirring. The flask containing the sample was withdrawn from the shaker at the predetermined time interval and filtered through Whatmann No. 44 filter paper.

The experiments were carried out under different conditions. The effect of initial COD values was investigated by keeping all the conditions constant except for a change in the initial COD concentration, using simulated COD bearing solutions prepared by dissolving a known amount of glucose in distilled water. The residual COD concentration was determined after each run.

Each sorbent was agitated with 10 g/l of wastewater of COD value 600 mg/l for different time periods, of between 30 and 220 minutes. After the predetermined time intervals, the samples were withdrawn and filtered and the residual COD concentration was determined.

100 ml of the sample was treated with different doses of sorbents (10-70 g/100 ml) to evaluate the effect of sorbent dose. A control sample with 0 g/100 ml was used to estimate sorption from any other matter than sorbent. The samples were agitated for a specific time, filtered and then analyzed for the residual COD.

The pH effect was studied taking a specific concentration, adsorbent dose, and contact time, and varying the pH values from 2 to 8 using dilute NaOH/HCl solutions. The samples were agitated for specific time, filtered and then analysed for the residual COD concentration.

## **RESULTS AND DISCUSSION**

The results observed after the physicochemical analysis of the wastewater as depicted in Table 1 indicate that domestic wastewater is highly polluted with organic load and suspended matter. Organic load is depicted in terms of COD and BOD.

The COD value is much higher than the permissible limit. The composition of flyash in Table 2 indicates that the flyash is predominantly silicious followed by the insoluble oxides of aluminium, iron, calcium, magnesium, titanium, alkali oxides and a negligible amount of phosphorus pentoxide and sulphur oxides. In case of flyash as an adsorbent, the metal salts hydrolyse in the presence of natural alkalinity to form metal hydroxides. The multivalent cations present in flyash can reduce the zeta potential while the metal hydroxides are good adsorbents. They form monomolecular layer on the surface of suspended organic matter and remove it by enmeshing them and settling.



Table 1. Physico-chemical properties of domestic wastewater

S.No.	Parameter	Value	Max permissible limit*
1.	pH	7.2	8-8.5
2.	Electrical conductance or EC (m mhos/cm)	1330	400
3.	Temperature (°C)	20.5	16-32
4.	Turbidity (NTU)	320	10
5.	Total solids (mg/l)	3491	.....
	Total suspended solids (mg/l)	341	.....
6.	Total dissolved solids (mg/l)	3150	2000
7.	Chemical oxygen demand (mg/l)	780	6
8.	Biochemical oxygen demand (mg/l)	383	6

These limits are for drinking water.

Table 2: Characteristics of sorbents

Characteristics	PTS	PLC	AC	FA
Density (g/cc)	2.20	2.50	1.40	1.80
Bulk density (g/ml)	1.6	1.8	1.20	1.21
Moisture (%)	11.31	16.31	3.61	15.0
Ash (%)	9.65	12.65	3.32	12.32
Volatile matter (%)	6.74	5.74	9.39	3.26
Loss of ignition	5.02	4.02	3.83	13.02
Chemical Analysis SiO <sub>2</sub> (%)	2.00	2.00	7.05	4.20
Al <sub>2</sub> O <sub>3</sub> (%)	0.02	0.02	2.05	2.10
CaO (%)	0.12	0.12	0.04	0.21
Fe <sub>2</sub> O <sub>3</sub> (%)	5.32	5.02	1.23	0.30
MgO (%)	3.02	3.00	1.10	0.10
Surface area (m <sup>2</sup> /g)	590.0	470.0	538.2	378.5

Figure 1 (below) represents the effect of initial COD value on the percentage COD reduction by PTS, commercial activated carbon and flyash at the optimum pH, adsorbent dose and the contact time. It is clear that PTS seems to be a fairly active adsorbent even at higher initial concentrations. At lower initial concentrations, the ratio of the initial number of moles available to the adsorbent surface area is low and subsequently the fractional adsorption becomes independent of initial concentration. At higher concentrations, the available sites of adsorption become fewer and hence the percentage removal of COD depends upon the initial concentration. The COD removal of over 90 percent to 96 percent obtained with PTS within the concentration range was investigated. The comparison in trend of percentage COD reduction by flyash with respect to commercial activated carbon under this condition is depicted in Figure 1 below.

Figure 1. COD percentage reduction by sorbents at pH 6, sorbent dose 10 g/l, contact time 1 h, temperature 20.5°C and rpm 150

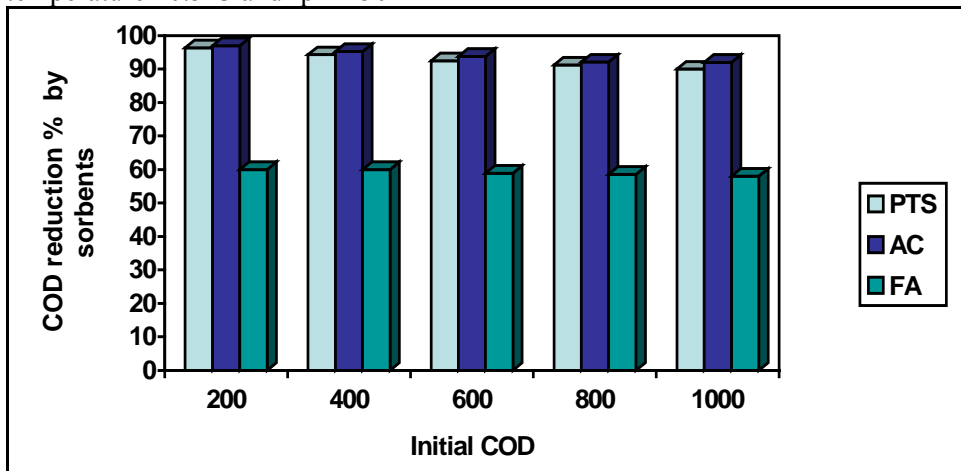

Figure 2. COD percentage reduction at different contact times and at pH 6, sorbent dose 10 g/l, initial COD 600 mg/l, temperature 20.5°C and rpm 150

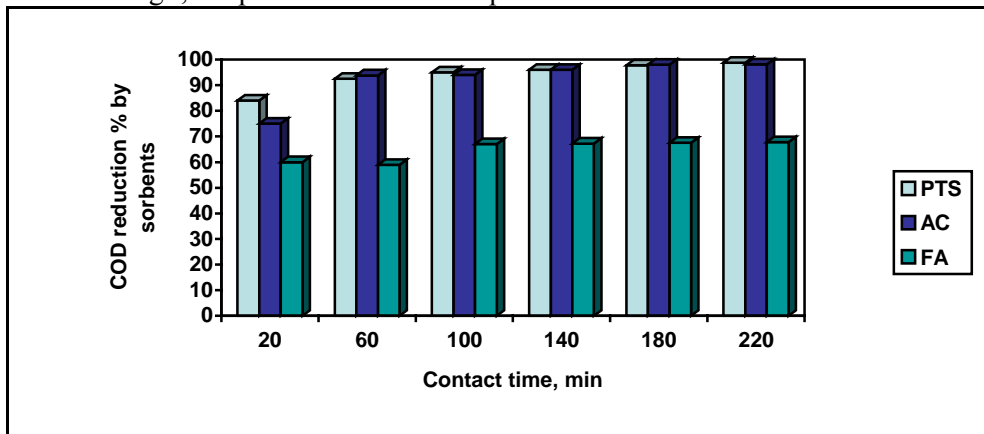

Figure 2 represents the percent removal of COD at different contact times by PTS, flyash and commercial activated carbon. It seems that COD removal has been achieved to the extent of more than 98.7, 98.1 and 67.8 % by PTS, AC and FA respectively at a maximum time period of 220 minutes and the trend of percent COD reduction with PTS was comparable to that of commercial activated carbon.

Figure 3. COD percentage reduction using different sorbet doses at pH 6, initial COD 600 mg/l, contact time 1 hr, temperature 20.5°C and rpm 150

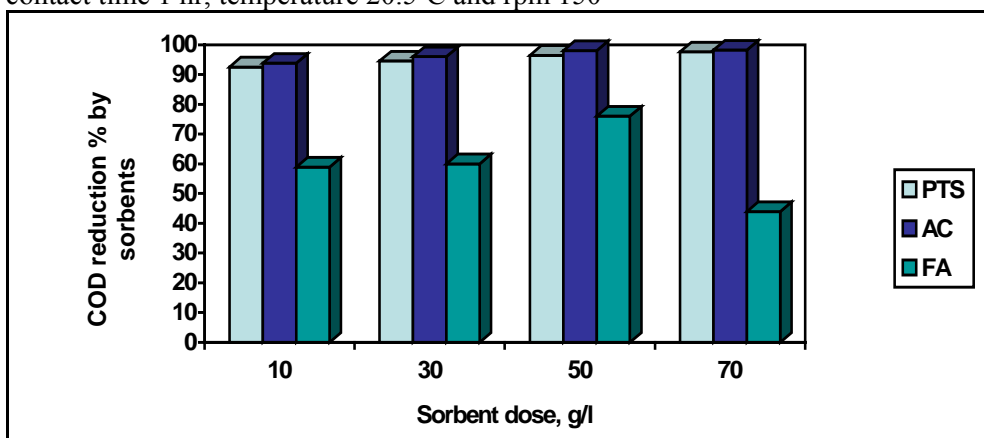
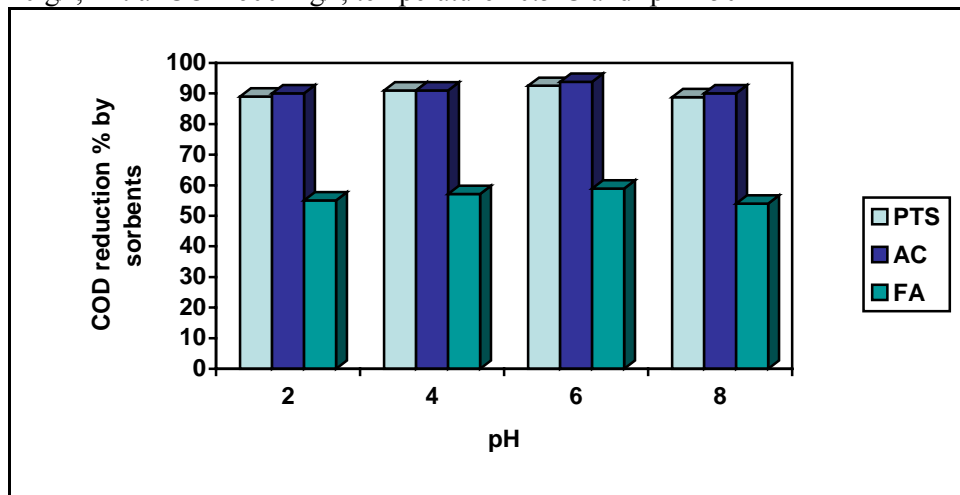

Figure 3 indicates the effect of adsorbent dose on the percent COD reduction by these sorbents. The equilibrium was then set up by further addition of adsorbent dose. Flyash did not show the same trend as that of commercial activated carbon. The results showed the tremendous increase in percent COD removal with the increment of adsorbent dose, owing to the increase in the number of sites. At lower doses, the significant small adsorption is possibly due to the saturation of surface active sites with the adsorbate molecules. According to the effect of pH on percent COD reduction by PTS, AC and FA, the runs were taken at the constant initial COD concentration, adsorbent dose and the contact time. The results indicate that at pH level 6.0, the sorbents have consistently higher adsorption capacity for COD.

At high pH the capacity of the adsorbent is recessed (Figure 4). The reason for the better adsorption capacity observed at low pH levels may be attributed to the larger number of  $H^+$  ions present, which in turn neutralise the negatively charged adsorbent surface, thereby reducing hindrance to the diffusion of organics at higher pH. The reduction in adsorption may be possible due to the abundance of  $OH^-$  ions, causing increased hindrance to diffusion of organics (contributing to COD) ions. Oxides of aluminium, calcium, silicon and iron are abundant in flyash that adsorb contaminants.

Figure 4. COD percentage reduction at different pH values and at contact time one hour, sorbent dose 10 g/l, initial COD 600 mg/l, temperature 20.5°C and rpm 150



## CONCLUSIONS

From the discussion above, the following conclusions can be reached:

- Results indicated that the COD can be reduced by up to 90 percent by PTS or AC while use of flyash reduces COD by up to 60
- The percentage of COD removal by PTS is fairly comparable to that of commercial activated carbon.
- Though its capacity of FA is lower than that of PTS or AC, the low material cost makes it an attractive option for the treatment of domestic wastewater.
- The treatment of domestic wastewater can be achieved not only by PTS or AC but also by flyash generated from thermal power plants or any factory to reduce the organic load.

## ACKNOWLEDGEMENT

The authors are grateful to the Council of Scientific and Industrial Research of India for funding this study through the project No. 01(1828)/02/EMRII. They also thank Dr O.P. Garg, Mr S.P. Garg and their trust Smt. Basanti Devi and C.L. Garg Educational Trust for getting their laboratory renovated.

## REFERENCES

Clesceri, L.S., Greenberg, A.E. and Eaton, A.D. (eds). 1998. 'Standard Methods for the Examination of Water and Wastewater', 20th edition. Washington DC: APHA, AWWA, WEF,

Banerjee, K., Cheremisinoff, P.N. and Cheng, S.L. 1995. 'Sorption of organic contaminants by flyash in a single solute system', *Environmental Science Technology*. 29: 2243-2251

Gupta, G.S., Prasad, G. and Singh, V.N. 1990. 'Removal of chrome dye from aqueous solutions by mixed adsorbents: flyash and coal', *Water Research*. 30: 24-45

Johnson, G.E., Hunka, L.M. and Field, J.H. 1965. 'Use of coal and flyash as adsorbents for removing organic contaminants from secondary effluents', *Ind. Eng. Chem. Proc. Design Develop.* 4: 323-327

Kőcí V., Ocelka T., Mlejnek M. and Grabic R. (2004) Efficiency assessment of wastewater treatment plant based on SPMD sampling. *Central European Journal of Chemistry* 2, 91-112

Lopez F.F., Cabrera C., Lorenzo M.L. and Lopez N.C. 2000. 'Aluminium levels in species and aromatic herbs', *Science Total Environment*. 257 : 191-196

Manka, J., Rebhun, M., Mandelbaum, A. and Bortinger, A. 1974. 'Characterization of organics in secondary effluents', *Environmental Science Technology*. 8: 1017-1020

Pandey, K.K., Prasad, G. and Singh, V.N. 1985. 'Copper Removal from aqueous solution by flyash', *Water Research* 9: 869-873

Seida, Y., Nakano, Y. and Nakamura, Y. 2001. 'Rapid removal of dilute lead from water by pyroaurite like compound', *Water Research* 35(10): 2341-2346

Viraragharan, T. and Dronamraju, M.M. 1992. 'Utilization of coal ash, water pollution control', *Journal of Environmental Studies*. 40: 79-85

# REMOVAL OF HEAVY METALS FROM ELECTROPLATING EFFLUENTS BY CARBONIZED AGROWASTES

R.P Singh, N. Gupta, R. Suman and Radha Gupta

School of Chemical Sciences, Chemistry Department, St. John's College, Agra

E-mail: [rp17\\_in@yahoo.com](mailto:rp17_in@yahoo.com)

## ABSTRACT

This paper discusses a study aimed to evaluate the feasibility of using powdered pseudoactivated carbon prepared from agrowastes for the removal of heavy metals from electroplating effluents. During the study, batch tests were conducted using an electroplating industry effluent that contained 18.0, 18.9, 8.6 and 15.6 ppm of Cr(VI), Ni(II), Cu(II) and Zn(II) respectively.

The ability of coconut coir carbon (CCC), sagaun sawdust carbon (SSC), wheat stem carbon (WSC) and rice husk carbon (RHC) to remove heavy metals from the effluent was studied. The removal was in the order of Ni > Zn > Cu > Cr over a wide range of initial concentrations: 1-20 mg/l at sorbent dose 1 g/l, pH 4.8, temperature 25°C, rpm 250 for five hours (5 h). The sorption increased with increasing contact time but the equilibrium was attained in two hours for Cr, 3.0 h for Cu, 3.5 h Zn and 4 h for Ni. The order of metal removal capacities for these chemical sorbents was: RHC > CCC > WSC > SSC. Electroplating effluent showed four to ten percent lower removal as compared to synthetic standard solution under similar conditions.

## INTRODUCTION

In India, there are over 50,000 large, medium and small electroplating units mostly scattered in urban areas. Most large units are captive to some other large industrial units (Chauhan and Chauhan, 2002). Medium units cater to selected business groups as feeder units. Small units mostly carry out job plating where, unlike captive and feeder units, most of the operations are performed manually by family-owned business in residential areas and there is no space for effluent treatment.

The variety of processes and methods of operation in the metal finishing industry gives rise to a wide range of effluent compositions (Pigage et al., 2002). The processing baths contain a high concentration of potentially polluting materials. In general, the wastewater can be expected to contain cyanides of potassium or sodium, complex cyanides, copper, nickel and zinc in acid solution, hexavalent chromium, oil wastes and solvents. Due to the proprietary nature of many products used in the metal finishing, the precise composition is quite often not known. Dissolved chemicals and metals, which are not toxic to aquatic life at very low concentration levels, are, however, the major concern. The permitted levels of metal contaminants in the electroplating wastewater to be discharged, as applicable in various parts of the world as well as in India, are very low, but the electroplating effluents have their very high levels. A typical wastewater from an electroplating industry is likely to have in ppm 100-500 suspended solids, 20-100 Cr(VI), 30-150 total Cr, 15-90  $\text{CN}^-$ , 5-25 Cu, 15-70 Ni and 10-200 Zn whereas the permitted levels of these contaminants in the electroplating wastewater to be discharged are 100, 0.1, 2.0, 0.2, 2.0, 2.0 and 5.0 ppm respectively. The pH is in the range of 4 to 10, and should be changed to between 6.5 and 7.5 before water is released into the environment.

Though activated carbon is an ideal adsorbent for organic matter due to its organophilic character, it is not economical for wastewater and soil treatment owing to its high production and regeneration costs, and about 10 to 15 percent loss during regeneration by chemical or thermal treatment. The high cost of activated carbon and synthetic resins has prompted the search for substitutes that are abundant, cheap, renewable and ecofriendly (Dakiky et al, 2002; Buerge-Weirich et al, 2002). Subsequently, the use of agricultural residues such as sawdust or industrial by-products like bagasse have received considerable attention (Achari and Anirudhan, 1995; Gaghate et al., 1990; Siddique et al., 1999; Haribabu, 1992;

Rai and Surendra, 1999; Rangaraj et al., 1999; Selvakumari et al. 2001; Singh et al., 2000). Most of these materials contain functional groups associated with proteins and polysaccharides like lignin, cellulose and hemicellulose. The pollutant uptake is believed to occur through coulombic attraction and ion exchange processes involving these groups. Though these materials generally do not have high sorption capacity as compared to activated carbon, they are plentiful, inexpensive and renewable. This offers an attractive approach to the removal of metal cations in solution. The sorption capacity of these materials could be enhanced by various physicochemical modifications to improve their physical and structural properties, making them more suitable for full-scale filter applications. The goal of this research is to evaluate the ability of coconut coir carbon (CCC), sagaun sawdust carbon (SSC), wheat stem carbon (WHC) and rice husk carbon (RHC) as effective, low cost, biomass sorption media to remove heavy metals from the electroplating effluent.

## MATERIAL AND METHODS

The sagaun sawdust used in this study was collected from the saw machine at Panchkuan, Agra. Coconut coir, rice husk and wheat stem were obtained from the local market. All the four agrowastes were dried in the sun, crushed, washed thrice with distilled water and rinsed with 1 percent HCl to remove water soluble impurities, particularly metal ions and surface adhered particles. Then they were kept in 0.1 N NaOH solution overnight to remove lignin and in 0.1 CH<sub>3</sub>COOH to remove alkalinity developed due to NaOH. Thereafter, they were washed well with distilled water till the wash water became colourless, and dried at 110°C in an oven for two hours to get rid of moisture and other volatile impurities. Their carbons were prepared by keeping four parts of the above agrowastes with three parts by weight of concentrated H<sub>2</sub>SO<sub>4</sub> in an air oven maintained at 150°C for 24 h. The carbonized agrowastes were washed with distilled water to remove free acid (SO<sub>4</sub><sup>2-</sup> ions). Then they were soaked in 1% w/v sodium carbonate solution overnight to remove any residual acid. Again they were washed with distilled water and dried at 110°C for two hours. The carbons so obtained were ground in a mortar with a pestle and sieved through a standard sieve to get the particle size less than 300 microns throughout the study.

All chemicals used were of analytical grade unless otherwise specified. Distilled deionized water (DDW) was used throughout the experiment. Five standard solutions of 1, 5, 10, 15 and 20 mg/l concentrations of Cr, Ni, Cu and Zn for instrument calibration and sorption study were prepared by diluting their stock solution of 1 g/l, i.e., 1 ml □ 1 mg metal. To prepare the Cr (VI) stock, 2.828 g anhydrous K<sub>2</sub>Cr<sub>2</sub>O<sub>7</sub> was dissolved in about 200 ml DDW, 1.5 ml conc. HNO<sub>3</sub> and diluted to 1 litre with DDW. The stock solution of Ni, Cu and Zn were prepared by dissolving 1.000 g of 99.5 percent AR 325 mesh metal powder from CDH, New Delhi in a minimum volume of 1:1 acid (HNO<sub>3</sub> for Ni and Cu, and HCl for Zn) and diluting to one litre with one percent (v/v) acid.

The capacity studies were carried out by transient batch tests. In 25 numbers (5 concentrations of 4 metals each + 5 controls one for each) of 100-ml capacity PVC bottles with screw caps, 0.05 g of sorbent was added to each bottle of 5 sets, each set having 6 bottles 5 for different concentrations of a metal and 1 for its control. 50 ml of the metal solution or effluent was added to each bottle. The solution was buffered with 0.07M sodium acetate - 0.03 M acetic acid to pH 4.8. Each bottle was shaken in a reciprocating shaker at 180 rpm for five hours at room temperature, and the metal concentration was measured per hour until the solution reached equilibrium. The control samples without sorbent were to demonstrate metal uptake due to the sorbent, not from other sources such as the walls of the container, centrifuge tube etc. The contents were centrifuged at 2000 rpm for 10 min and the supernatant liquid was filtered using a 0.45-µm membrane filter. The filtrate was analysed for metal ions. The initial and final concentrations of the metal solutions were determined using a Perkin-Elmer A-Analyst 100 AAS by Standard Methods (APHA et al., 1998). Experiments were triplicated and results averaged.

## RESULTS AND DISCUSSION

The characteristics of the final solutions are listed in Table 1 below. Such carbons are expected to be more than four times more effective than raw agrowastes (Manju and Anirudhan, 1997; Perisamy and Namasivayam, 1995).

Table 1. Characteristics of Adsorbents

Parameters	RHC	CCC	WSC	SSC
Composition (in %)				
Moisture	3.82	4.96	5.67	4.22
Ash	4.56	7.85	5.68	8.36
Carbon	79.89	80.32	78.9	81.73
Silica	2.76	4.36	3.02	4.64
Sodium	0.13	0.11	0.17	0.09
Potassium	0.29	0.31	0.27	0.23
Calcium	0.35	0.39	0.41	0.32
Magnesium	0.03	0.02	0.07	0.01
Phosphorous	0.05	0.04	0.06	0.03
Iron	0.27	0.19	0.32	0.12
Miscellaneous	7.85	1.45	5.34	0.25
Properties				
pH	8.32	7.64	7.34	7.83
Conductivity ( $\mu\text{S}/\text{m}$ )	0.92	0.80	0.75	0.62
Specific gravity (g/L)	1.20	1.34	1.10	1.12
Porosity (ml/g)	1.01	0.92	0.83	0.72
Surface area ( $\text{m}^2/\text{g}$ )	456	397	328	298
Cation exchange capacity(meq/g)	0.70	0.90	0.53	Nil

The physicochemical properties of carbonized agrowastes vary widely from plant to plant and method to method of carbonization. They depend on the variety of a plant and area in which it is cultivated, temperature of carbonization, operational features and efficiency of the heating equipment like oven or furnace, The peaks of their X-ray diffractogram can be used to identify major components, such as crystalline quartz, amorphous silica, calcium orthosilicate, cristobalite, sillimanite, crystalline carbonate etc. (Swamy et al. 1998). Their scanning electron micrographs can depict their morphology, particularly linear or curved type fibers with holes in the fibers and other places in the skeletal structure. The number and size of pores of a carbon can also be determined. More numerous and larger-sized pores but smaller particle size make a better sorbent. The bands of their FTIR spectra can indicate the presence of carboxy, hydroxyl and sulphonic groups responsible for cation exchange.

Table 2. Effect of Cr, Ni, Cu and Zn concentration on their % removal at agitation time 4 h, rpm 240 and sorbent dose 1 g/l, pH 4.8 and temperature 25°C

Metal	Concentration (mg/l)*	RHC	CCC	WSC	SSC
Cr(VI)	1	92.1	90.9	88.3	85.1
	5	89.5	88.2	84.5	80.0
	10	84.2	82.4	76.8	70.9
	15	75.7	71.1	65.9	58.4
	20	68.1	62.3	56.1	48.5
Ni(II)	1	97.6	95.9	94.3	92.8
	5	97.0	94.7	92.7	90.4
	10	95.5	91.9	88.4	84.5
	15	91.3	86.0	79.6	71.2
	20	84.2	76.6	70.9	62.9
Cu(II)	1	94.2	93.6	91.9	88.0
	5	92.7	91.7	89.0	83.6
	10	89.2	86.9	83.9	76.1
	15	81.2	78.9	73.4	62.3
	20	72.5	68.6	63.4	54.1
Zn(II)	1	95.4	94.7	92.3	90.8
	5	94.2	93.2	90.6	87.0
	10	91.5	89.4	84.5	80.2
	15	85.2	80.9	75.2	68.1
	20	78.5	72.1	64.2	56.5
Cr(VI)	18.0	67.4	61.0	55.7	47.2
Ni(II)	18.9	83.0	75.2	68.5	60.3
Cu(II)	8.6	89.0	86.5	83.4	75.5
Zn(II)	15.6	81.0	75.4	68.3	60.7

\*The second set of data is for metal ions present in electroplating effluents.

Figure 1. Effect of contact time on the % removal of Cr at 5 mg/l concentration, sorbent dose 1 g/l, pH 4.8 and temperature 25°C

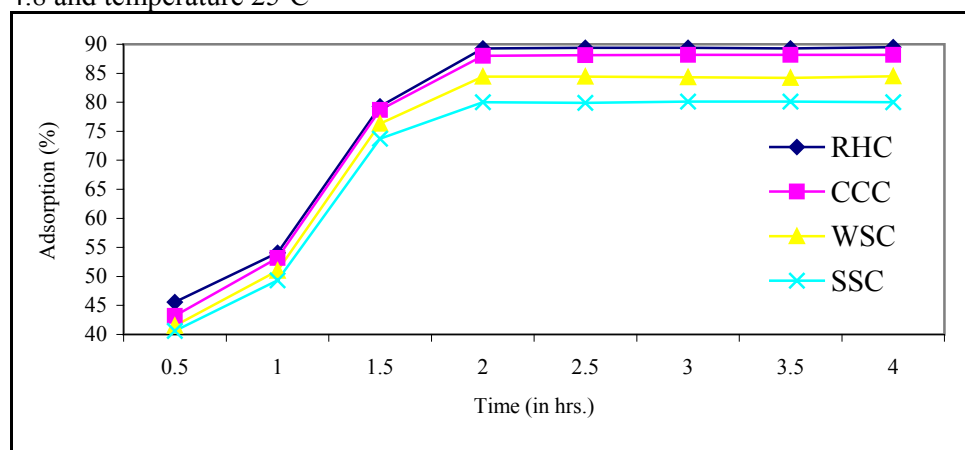

The effect of contact time on sorption was also investigated (Figure 1) The uptake of metal ions at 1, 5, 10, 15 and 20 mg/l concentrations by different sorbents was thus calculated and results are listed in Table 2.



The data were analysed using the Freundlich and the Langmuir equations:

$$\ln a = \ln k + 1/n \ln c \quad \text{Freundlich equation}$$

$$c/a = 1/Qb + c/Q \quad \text{Langmuir equation}$$

where a (mg/g) is the metal sorbed per unit mass of sorbent ( $a = x/m$  where x mg of metal is sorbed on m grams of sorbent), c (mg/l) is equilibrium concentration in aqueous phase, k (mg/g) and n are Freundlich constants related to adsorption capacity and adsorption intensity respectively, Q (mg/g) and b (l/g) are Langmuir constants related to adsorption capacity of sorbent and adsorption maximum (energy of adsorption) respectively. The Langmuir constants were calculated at five initial concentrations under optimal conditions (Table 3).

Table 3. Comparison of Langmuir and Freundlich constants and correlation coefficients ( $R^2$  values) for the sorption of heavy metals by RHC, CCC, WSC and SSC

System	Langmuir constants and $R^2$			Freundlich constants and $R^2$		
	Q, mg/g	b, l/g	$R^2$	k, mg/g	1/n	$R^2$
Cr/RHC	15.5637	0.7730	0.9975	7.422	0.5057	0.9665
Cr/CCC	14.3753	0.7581	0.9986	6.985	0.4686	0.9529
Cr/WSC	13.1134	0.6130	0.9998	6.199	0.4605	0.9759
Cr/SSC	11.4383	0.5978	0.9999	5.102	0.4311	0.9531
Ni/RHC	18.7713	2.3191	0.9993	16.956	0.4823	0.9501
Ni/CCC	17.1763	1.4426	0.9998	11.884	0.4753	0.9484
Ni/WSC	15.8784	1.1181	0.9984	9.430	0.4782	0.9503
Ni/SSC	14.0016	0.9786	0.9965	7.413	0.4551	0.5266
Cu/RHC	17.1083	1.0063	0.9991	9.697	0.4839	0.9512
Cu/CCC	15.6278	0.9955	0.9998	8.936	0.4718	0.9523
Cu/WSC	14.2539	0.8527	0.9995	7.511	0.4501	0.9530
Cu/SSC	12.2523	0.6460	0.9977	5.539	0.4505	0.9534
Zn/RHC	18.3009	1.1852	0.9979	11.151	0.5088	0.9584
Zn/CCC	16.3204	1.1634	0.9987	9.922	0.4744	0.9488
Zn/WSC	14.9322	0.8557	0.9998	8.269	0.8023	0.9445
Zn/SSC	12.5572	0.8492	0.9139	6.878	0.4147	0.9468

Sorption capacity is found to decrease with increase in metal concentration. The higher uptake at lower initial concentration can be attributed to the availability of more isolated metal ions. Sorption rate is very rapid during initial the contact period due to the availability of more sites for sorption. More than 60 per cent of sorption is reached within 1 hour. However, equilibrium was attained after two hours for Cr, three hours for Zn, 3.5 hours for Cu and four hours for Ni. RHC could remove a greater amount of these metals than any other carbon studied. It was found to remove 92.1 percent Cr (VI), 97.6 percent Ni, 94.2 percent Cu and 95.4 percent Zn at concentration 1 mg/l, sorbent dose 1 g/l, rpm 240, agitation time 4 h, pH 4.8 and temperature 25°C. The order of metal removal capacities for these chemical adsorbents was RHC > CCC > WSC > SSC. The order of removal/sorption of metals was Ni > Zn > Cu > Cr. The effect of various parameters affecting the adsorption such as initial metal concentration, adsorbent dose, contact time and pH was determined. Adsorption decreases with rise in metal concentration but increases with increase in adsorbent dose.

The rate of adsorption is high in the beginning as sites are available and unimolecular layer increases. Adsorption and desorption occur together and rates become equal at a stage called adsorption equilibrium when isotherms are applied. That is why there is little increase in the percentage removal when the contact time is increased from four to five hours. The subsequent slow rise in the curve may be due to adsorption and intra-particle diffusion that occurs simultaneously with dominance of adsorption.

The pseudoactivated carbons may consist of oxides of silicon, calcium, magnesium and iron, for example. They may have anion adsorption sites similar to minerals like alumina and clay. Such sites are aquo groups ( $\text{—M—OH}_2^-$ ) and hydroxo groups ( $\text{—M—OH}$ ). The surface chemistry of an oxide in contact with an aqueous solution is determined to a large extent by deprotonation or a hydroxyl ion association reaction. However, some evidence suggests that an anion like  $\text{Cr}_2\text{O}_7^-$  can be adsorbed by an ion exchange mechanism even though the surface is neutral. Had Cr(VI) not been in dichromate form, it would have been adsorbed to the maximum extent based on its ionic size and potential.

The optimum pH for metal removal was found in the acidic medium (Singh et al. 2001). This may be attributed to the large number of  $\text{H}^+$  ions in the acidic medium that neutralize the negatively charged adsorbent surface, thereby reducing hindrance to diffusion of dichromate ions. At higher pH, the abundance of  $\text{OH}^-$  ions create increased the difficulties in the diffusion of dichromate ions.

## CONCLUSIONS

The following conclusions can be drawn from the above results:

- CCC, SSC, WSC and RHC remove heavy metals from the effluent in the order of  $\text{Ni} > \text{Zn} > \text{Cu} > \text{Cr}$  over a wide range of initial concentration 1-20 mg/l at sorbent dose 1 g/l, pH 4.8, temperature 25°C and rpm 250 for five hours.
- The sorption increased with decreasing metal concentration and increasing contact time, but the equilibrium was attained in 2 h for Cr, 3.0 h for Cu, 3.5 h Zn and 4 h for Ni.
- The order of metal removal capacities for these chemical sorbents was:  $\text{RHC} > \text{CCC} > \text{WHC} > \text{SSC}$ .
- Electroplating effluent showed four to ten percent lower removal as compared to synthetic standard solution under similar conditions.
- The sorption followed Freundlich as well as Langmuir isotherms.
- The present paper shows the possibility of using agrowastes particularly rice husk abundantly available in our country to produce cheaper activated carbons. The data thus generated may be used for designing treatment plants for industrial effluents having low levels of heavy metals and hold a promise for commercial exploitation.

## ACKNOWLEDGEMENT

The authors thank Dr O.P. Garg (an NRI scientist/businessman from Hamberg), his brother Mr S.P. Garg (an eminent architect from Delhi) and the Smt. Basanti Devi and C.L. Garg Educational Trust for renovating our laboratory and providing research facilities as well as encouragement.

## REFERENCES

- Achari S.V. and Anirudhan J.S. 1995. 'Phenol removal from aqueous system by sorptions of jackwood sawdust', *Indian Journal of Chem. Technology*, 2: 137-141
- APHA, AWWA and WEF. 1998. 'Standard Methods for the Examination of Water and Wastewater'. 20th edition, Clesceri, L.S., Greenberg, A.E. and Eaton, A.D. (Editors), APHA, AWWA, WEF, Washington DC
- Buerge-Weirich D., Hari R., Xue H., Behra P. and Sigg L. 2002. 'Adsorption of Cu, Cd and Ni on goethite in the presence of natural groundwater ligands', *Environ. Sci. Technol.*, 30, 320-330

- Chauhan S. and Chauhan S.V.S. (2002) 'Chemical characteristics of effluents of two important industries at Agra', *Nature Environment and Pollution Technology*, 1(4), 431-433
- Dakiky M., Khamis M., Manassa A., Merdo M. (2002) 'Selective adsorption of chromium(VI) in industrial wastewater using low cost abundantly available adsorbents', *Advances in Environmental Research*, 6, 533-540
- Gajghate D.G., Saxena, E. R., and Rao, M. (1990) 'Kinetics of adsorption of lead by activated carbon from aqueous solution', *Ind. Journal of Environmental. Health.*, 32, 369-376
- Haribabu E., Upadhyay S.N. and Upadhyay Y.D. 1992. 'Removal of chromium(VI) by flyash', *Chem. Environ. Pes.* 1(3), 289-294
- Manju G.N. and Anirudhan T.S. 1997. Use of coconut fibre pith-based pseudo-activated carbon for chromium (VI) removal. *Ind. Journal of Environmental. Health.* 39(4), 289-298
- Perisamy K. and Namasivayam C. 1995. 'Removal of Ni(II) from aqueous solution and nickel industry wastewater agricultural wastes: peanut hulls', *Waste Management.* 15(1), 66-68
- Pigage A., Juskenas R. and Selskis A. 2002. 'Waste treatment of two electroplating solution of Cu and Zn by mixing and precipitation', *Separation Science and Technology.* 37(13), 3155-3168
- Rai and Surendra Kumar A.K. 1999. 'Treatment of chromium bearing wastewater by adsorption on brick kiln ash and flyash', *Ind. Journal of Environmental Health.* 41(1): 65-73
- Rangaraj S., Arabindoo B. and Murugesan V. 1999. 'Sorption characteristics of parachlorophenol on activated palm seed coat carbon', *Ind. Journal Environmental Health.*, 41(1): 16-23
- Selvakumari G., Murugusan M., Patabi, S. and Satish Kumar, M. 2001. 'Sorption of metals from electroplating industry effluent by maize cob carbon'. Proceedings, X National Symposium on Environment, BARC, Mumbai, 133-135
- Siddique B.A., Sharma P.P. and Mohamad S. 1999. 'Adsorption studies on phosphate treated sawdust: Separation of Cr(VI) from Zn(II), Ni(II), Cu(II) and their removal and recovery from electroplating waste', *Ind. Journal of Environmental. Protection.* 19(11), 846-852
- Singh R.P., Singh Y. and Swaroop D. 2000. 'Defluoridation of groundwater in Agra city using low cost adsorbent'. *Bull. Environ. Contam. Toxicol.*, 65, 120-125
- Singh R.P., Singh Y., Swaroop D., Gupta N. and Singh S. 2001. 'Comparison of activated carbon, fly ash, rice husk and saw dust for the removal of Cr, Zn, Cd and Pb from wastewater'. Proceedings RAWM-2001, IAEM, 285-289
- Srinivasan K., Balasubramanian N. and Ramakrishnan T.V. 1988. 'Studies on chromium removal by rice husk carbon', *Ind. Ournal of Environmental Health.* 30: 376
- Swamy M.M., Mall I.D., Prasad B. and Mishra I.M. 1998. 'Sorption characteristics of o-cresol on baggase flyash and activated carbon', *Ind. Journal of Environmental Hlth.*, 40(1): 67-78

# ASH'SHARQIYAH SANDS WATER SUPPLY SCHEME

Eng. Zaher Bin Khalid Al Sulaimani, Eng. Said Bin Khamis Al Khamisi, Dr. Ali Gharbi, Eng. Ziad Al Aswad;  
Ministry of Regional Municipalities, Environment & Water Resources, Sultanate of Oman;  
Email: ddgwrw@ mrmewr.gov.om

## INTRODUCTION

In recent years, some towns and villages in the Ash'Sharqiyah region of the Sultanate of Oman have been faced with water shortages and deterioration in the quality of drinking water as a result of the continuing increase in water demands and prolonged drought periods.

Explorations carried out between 1989 and 1997 confirmed the existence of groundwater resources in aquifers beneath Ash'Sharqiyah Sands and the gravel plain north-east, suitable for drinking water supply and large enough to meet drinking water requirements .

Then, a pre-feasibility study was carried out in 1997, and options for the development of the aquifer were investigated and compared. Based on this study the Ministry chose the best option, and a feasibility study was undertaken to examine the financial viability and economic returns from the project.

In June 1999 the detailed design and supervised construction of Ash'Sharqiyah sands water supply scheme was started. Briefly, the design of the chosen scheme envisages the exploitation of the discovered aquifer through the development of two well fields and water supply to major towns - Al Kamil and Al Wafi, Falaj Al Mashaiekh, Jaalan bani Bu Hassan and Jalaan bani bu Ali and Al Ashkharah. The extension of the system to cover the coastal area of Jaalan Bani Bu Ali started on January 1<sup>st</sup>, 2004 and will be completed in the first quarter of 2005.

The scheme will initially supply about 79,000 people with fresh, safe drinking water. At the end of the 30-year life of the project, it is anticipated that a total of about 196,000 people will be supplied.

## HYDROLOGICAL STUDIES

Prior to 1973, there were no meteorological stations in the Ash'Sharqiyah region apart from one on the offshore island of Masirah. During the 1970s and in the course of various water resources studies, a number of rainfall stations were installed from 1982 to 1984. A climate station was set up at Sur by the Meteorological Department of the Ministry of Communications in 1982. Furthermore, 39 rainfall stations were installed in 1993-94, mainly for the Wadi al Batha project; some of these stations being replacements for 10 former long-term rainfall stations closed in 1993. This brings the current Ash' Sharqiyah rainfall station network to 53.

### Climate

In Oman, the year is divided into two distinct seasons. During the winter months (November to April) the wind comes predominantly from the north. These air masses can produce significant rainfall when modified by depressions associated with cold fronts moving south-eastwards from the Mediterranean or when encountering moist air moving inland from the Gulf of Oman.

During the summer months (May to October) the primary influence of climate is the northerly movement of the Inter-Tropical Convergence Zone (ITCZ). This separates the north-westerly winds from the moisture-laden south-westerly monsoon air masses, often called "the khareef". The incidence of summer rainfall in Northern Oman depends on the location of the ITCZ and local effects produced by the Hajar mountain range and area.

## Rainfall

Average annual rainfall for Ash'Sharqiyah in the 21 year period from 1976 to 1996 varied from 80 mm to approximately 190 mm. Isohyets constructed between 1975 and 1992 show, with the aid of rainfall-elevation relationships, that annual rainfall in the northern part of the project area can be expected to exceed 125 mm and in much of the Ash'Sharqiyah Sands is likely to be less than 75 mm. Using the Isohyets map, average annual rainfall in Wadi al Batha north of Jaalan Bani bu Ali has been calculated as 619 millions m<sup>3</sup>/yr (832 millions m<sup>3</sup>/yr if the study area of Ash'Sharqiyah sands is included).

## Wadi flows

Within Wadi al Batha there are 13 wadi gauging stations. Eight of these gauges are located in the middle catchment within or close to the main project area. The period during which records were taken for these stations varies considerably. Sabt in Wadi Bani Khalid has the longest record (1938-1996), followed by Bani Bu Hasan and Bani Bu Ali in Wadi Al Batha (both, 1991-1996). The other stations have useable records stretching from 1993 to 1996.

The average annual recorded inflows amount to approximately 18 mm<sup>3</sup>/yr. At the bottom end of the middle catchment, at Bani bu Hassan, only 2.4mm<sup>3</sup>/yr is recorded. This phenomenon indicates high recharge of wadi flows along the main Wadi al Batha. The average annual flow from Wadi Bani Khalid, Sabt, accounts for the largest flows amounting to some 12.5 millions m<sup>3</sup>/yr. On the basis of the available records, the flows from Wadi Bani Khalid represent more than 60 percent of the total measured flows of Wadi al Batha.

## Aflaj flow

Of the 74 *aflaj* in Wadi al Batha, 31 fall within the main project area and on the edge of the Ash'Sharqiyah sands, between Al Ghabbi and Bani bu Ali. The average annual falaj flow of the 31 aflaj is around 33.4 million m<sup>3</sup> per year. One *falaj* in Sabt, in Wadi Bani Khalid, is also included in this table because it lies within the study area. A further 11 *aflaj* are to be found upstream of Sabt.

In Al Ghabbi, serious declines in flows have occurred in *Falaj* Al Wasil and Hawiya, and as already noted Falaj Hataw is now dry, although whether it was due to declining flows or poor maintenance is not clear.

In the down gradient of Al Ghabbi, in the Al Wafi and Al Kamil *aflaj*, there are also definite signs of declining flows. In the case of Falaj Al Wafi there is a downward trend of 2.6 l/sec/year, to a current level of ~ 70 l/sec. At Bani Bu Hasan, there are only three long records, two of which suggest slight declines in flows. At Bani Bu Ali, all three of the long term records show definite signs of declining flows. In the case of Falaj Adhahir there is a downward trend of 1 L/sec/year, to a current level of about 11 L/sec/year. At Falaj Mashaikh, apart from the rapid and steady decline of Falaj Mashaikh, the two other *aflaj* have shown fairly steady flows over the years.

The declining flows are not only the result of declining rainfall. The most likely explanation is that groundwater levels in these areas have been adversely affected by increased groundwater abstractions.

## Remote sensing studies

Remote sensing technology has been applied to assist a number of project studies within the project area. Basic research activities were undertaken, each focusing on a major component of the regional water balance, as follows:

Regional vegetation analysis including differentiation of *aflaj*- and non-*aflaj*-feddan agriculture; and Evaluation of the extent and density of natural woodlands (*Prosopis cineraria*) in the project area.

The results indicated that the prosopis forest is a significant consumer of water, covering about 13.000 ha (approximately 85 km long and 20 km wide), and the total number of prosopis trees is about 555.000.

## Aquifer assessment work

Water resources monitoring (in terms of quantity and quality) started at the beginning of the eighties. However, major assessment works started in 1991 in the upper catchment area under the auspices of the Wadi Al Batha Project. As a result of the deteriorating water resource situation, the assessment works shifted to the lower catchment area in the vicinity of Jaalan bani Bu Hasan, Jaalan bani Bu Ali and Ash'Sharqiyah Sands.

## Geography and physiography of the study area

The groundwater resources assessment study area, shown on Figure 1 below, covers about 6.080 km<sup>2</sup>. The groundwater resources of the region are recharged by high intensity, low frequency rainfall events that generate runoff in the hard rock mountain catchments of Al Hajar Ash'Sharqiyah. Much of the runoff is lost to evaporation but a proportion infiltrates and flows south and south-east into the alluvial plain, wadis and aquifers. It then drains into Ash'Sharqiyah Sands and Wadi Al Batha, which is forced eastward by the northern edge of Ash'Sharqiyah Sands, capturing three southerly- and a westerly- draining wadis on its journey to the sea at Asilah.

Figure 1 - Location of the study area

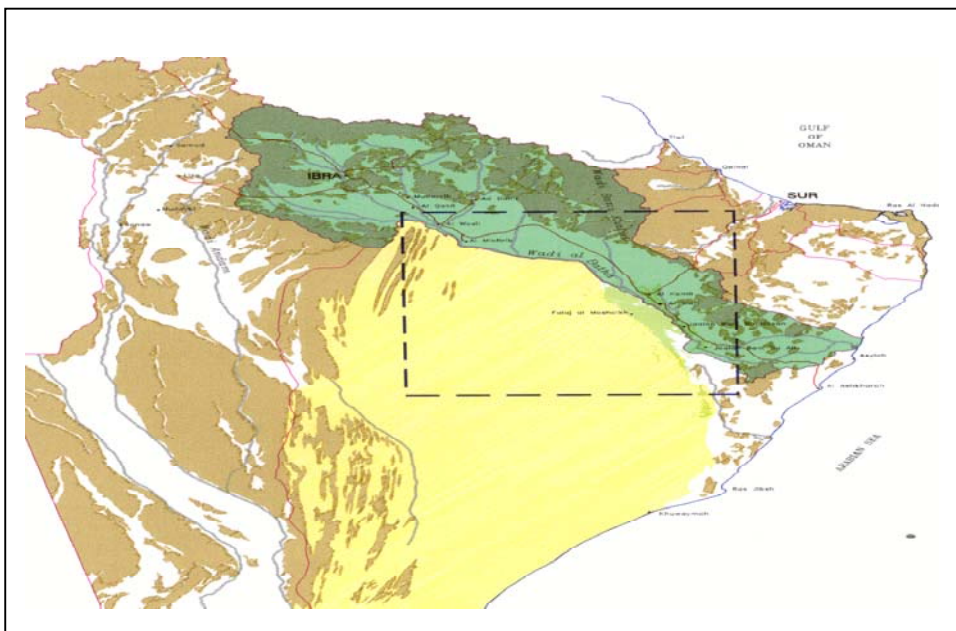

Ash'Sharqiyah Sands is roughly triangular in shape and at its maximum is about 100km wide (east to west) and 200km long (north to south), covering a total area of approximately 12,000 km<sup>2</sup> of which 3400km<sup>2</sup> lies in the Rimal Ash'Sharqiyah. To the east, the Rimal Ash'Sharqiyah is bounded by a discontinuous area of *sabkhas* and the Arabian Sea. The amount of natural scrub and woodland vegetation in Wadi Al Batha is considerable.

## Geological setting

The Eastern Oman Mountains which form around the northern and eastern margins of the study area are made up of eight distinct assemblages of rocks, which, from older to younger comprise:

- Pre-Cambrian gneiss and schists of Jabal Jaalan;

- A sequence of pre-Permian rocks that are exposed near Muscat, and in the Ash'Sharqiyah Sands are represented by the Huqf (Cambrian) and Haima (Cambro-Ordovician ) Group;
- The Hajar Super Group. These rocks are exposed in an isolated outcrop 15km north of Al Kamil at the edge of Jabal al Hajar Ash' Sharqi;
- The Hawasina, which are deep marine sedimentary rocks (radiolarian charts and solidified carbonate turbidities) of the same general age as the Hajar Super Group. These rocks are exposed to the west of the study area on the edge of the northern Ash'Sharqiyah Sands, to the north along the edge of Jabal al Hajar Ash' Sharqi, and between Jabal Jaalan and the coast;
- The Metamorphic Sole is an irregular contact of metamorphic rock located between the Hawasina and lower portion of the Samail Nappe. These rocks don't appear to find expression in the study area but do occur some 30 km northwest of Mintirib in Wadi Dahir;
- The Samail Nappe. These rocks do not extend into the study area but are exposed on the southern mountain front;
- Shallow-marine and terrestrial tertiary formations. These may lie unconformable on all other rock units,(i) to (vi) above;
- Quaternary alluvium is found throughout the study area in alluvial fans, terraces, wadi channels, and beneath the Ash'Sharqiyah Sands and varies in thickness from a few meters to in excess of 100m. The alluvium, consists of gravels, sands and clays, with variable carbonate cementation and is the main source of potable water in the region .On top of the alluvium, in the Ash'Sharqiyah sands, and sometimes inter-fingered within it, occur aeolianite and sand deposited on a surface having relatively little relief and which sloped from the northwestern corner of Ash'Sharqiyah Sands to the modern Barr al Hikman.

## **SUMMARY OF WATER RESOURCES INVESTIGATIONS**

Major programs of electromagnetic sound resistivity sounding and seismic reflection profiling have been carried out.

### **TDEM surveys**

In 1944, a total of 12 northeasterly TDEM cross-sections were surveyed to map the fresh water aquifer beneath the shallow saline zone Jaalan. The results show that the high resistivity aquifer zone thins and increases in salinity towards the south, and is bounded in the east by the faulted Hawasina contact. Figure 2 shows a resistivity section extending southeast along the wadi from west Jaalan bani bu Hasan to Southeast Jaalan bani Bu Ali.

Four additional time-domain electromagnetic (TDEM) surveys were made in 1997, extending to the coast, and these were successful in mapping electrical resistivity boundaries associated with increasing salinity and /or increasing clay content.

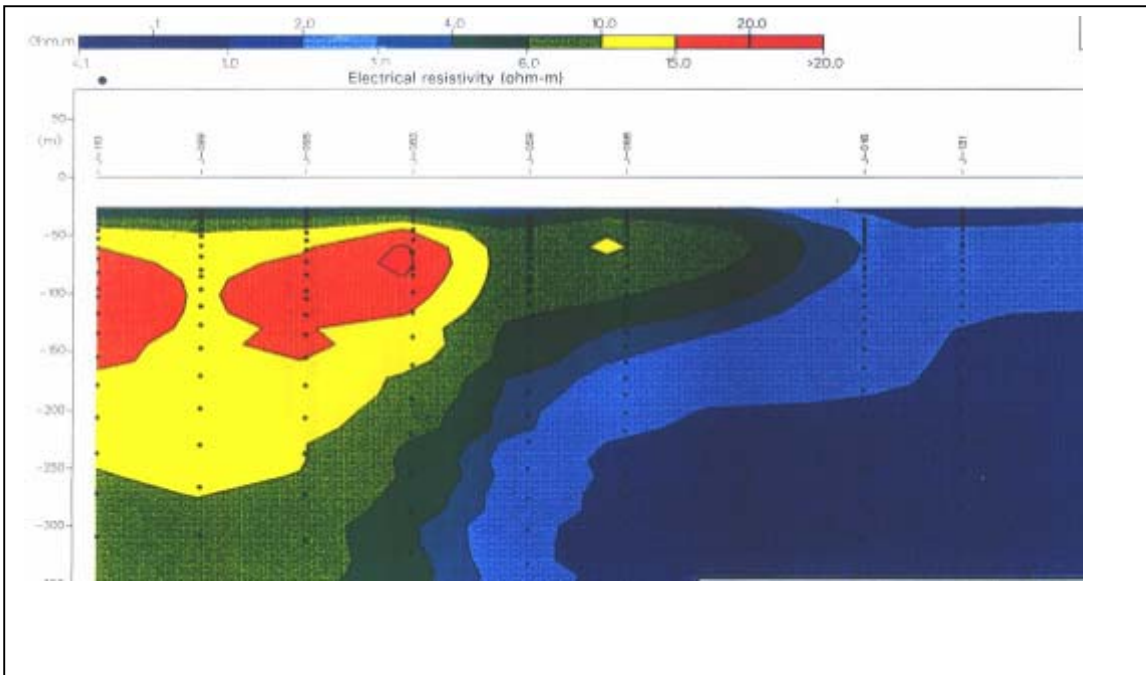
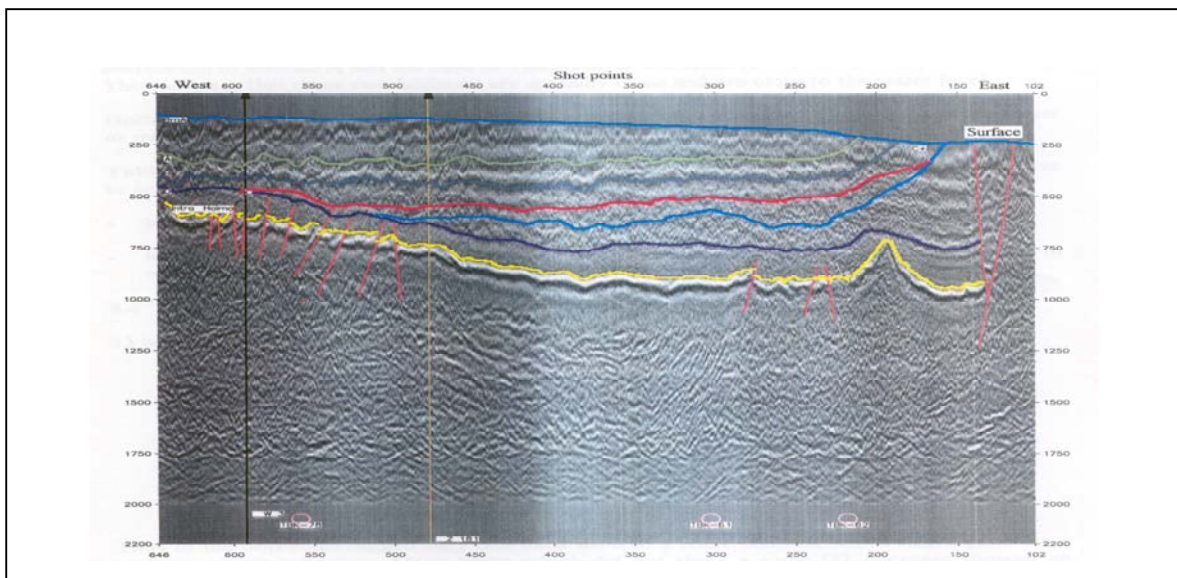

Figure 2 : Resistivity Cross Section

### Seismic results

Deep seismic reflection profiles were run by Amoco Oman Oil Company in the 1980s. As part of the present study, some of these have been reprocessed and re-interpreted to reveal the gross structural and sedimentological features of the tertiary basin in which the aquifer lies. Several horizons were mapped, in order of depth, as shown on Figure 3 below.

Figure 3 : Seismic cross-section





## **Geophysical borehole logging**

71 boreholes have been geophysically logged in the study area, in four phases:

- by PAWR in the period 1984 to 1986.
- by Wadi al Batha project until June 1995.
- by Badiyah project until April 1996.
- by the (previous) MWR Geophysics Section from May 1996

Resistivity, sonic and porosity logs indicated potentially high yielding intervals of the gravels. These logs also clearly indicated the formation of water level intersected by mud-filled holes. The gamma-ray signature of the clays in the gravel alluvium was muted, and the sonic log is considered to be a more indicator of clays. The geophysical characteristics of the alluvium were very variable over short vertical distances and it was difficult or impossible to correlate downhole log horizons laterally between boreholes spaced more than 1.5 km apart. The aeolianite is more consistent and shows characteristic resistivity and gamma responses. The increase in groundwater salinity with depth in the aeolianite is clearly indicated.

## **Drilling investigations – Phase 1**

Drilling in Wadi al Batha was carried out in three main phases. The purposes of these drilling contracts were to:

- calibrate the geophysical methods in the widespread alluvial environment of the project area, and to assess their efficiency in locating maximum thicknesses of alluvium for future drilling programs;
- enhance the existing water level and hydro-chemical monitoring networks, much of which consisted of hand-dug wells, a source of data inadequate for either purpose;
- acquire information about the yields and quality of water in the alluvium and weathered bedrock.
- prove the sustainability of well yields;
- measure the response of the aquifer to abstraction and to provide quantitative information on aquifer properties for use in modeling;
- enhance the existing Wadi al Batha water level and hydro- chemical monitoring networks and to extend them beneath Ash'Sharqiyah Sands;
- collate, by drilling and pump-testing, data for the lithology, yield and groundwater quality of aquifers underlying Ash'Sharqiyah Sands and to determine aquifer geometry; and
- determine the sustainability of well and aquifer discharges and to identify sites suitable as potential sources of water for the towns of the region.

In total 149 boreholes were drilled.

## **Aquifer testing**

The pumping test programme comprised 33 short constant rate aquifer tests of four hour's duration carried out on all wells with significant yield, and 13 more prolonged aquifer tests of one to seven days duration. In addition, a four-day group test was performed on the four test wells at the WAB230 site (Figure 4) to demonstrate the feasibility of pumping large volumes of water from Ash'Sharqiyah Sands. This site was selected because of its proximity to Al Kamil and high specific capacity.

Figure 4 – Pumping Test for WAB230



Distance- drawdown plots of data from individual tests at the WAB230 test-site would suggest that the radius of influence was less than 1,200m when pumping at the rate of less than 65 l/sec, after three days of pumping.

Airlift and pumping test data indicate that the aeolianite is generally of good quality. The productivity of the alluvium is highly variable with airlift yields in the range 1-73 l/s. For the alluvium, the EC is less than 2,000  $\mu\text{/cm}$  beneath the northeastern Wahaybah, increasing southwestward to more than 5,000  $\mu\text{/cm}$ .

### **Groundwater sampling, analysis and potability**

Hydrochemical assessment work involving laboratory analysis has been undertaken in the Sharqiyah Region since 1982. A hydrochemical and groundwater assessment of the Rimal Ash'Sharqiyah/ Jaalan areas has been compiled as part of the project (MWR, 1996). This was followed by an internal MWR laboratory report (MWR, October 1996) providing a preliminary assessment of the potability of water from the principal alluvial and aeolianite aquifers. Furthermore, comprehensive analyses have subsequently been completed, based on samples taken from potential development areas.

### **Alluvial aquifer**

Sample locations and EC distributions are shown in Figure 5. The EC=2,500  $\mu\text{/cm}$  contour encloses the courses of Wadi al Batha and Bani Khalid and extends southward some distance beneath the sands. Analysis of the less common trace metals and phenols included within the Omani Standard have been executed at ten sites. The reference potability standard for a number of parameters was met, with the exception of few sites within the EC(-TDS) delimited area. All anomalies appear isolated and do not, in any material sense, affect an overall potable classification for the entire area within the EC (-TDS) delimited area.

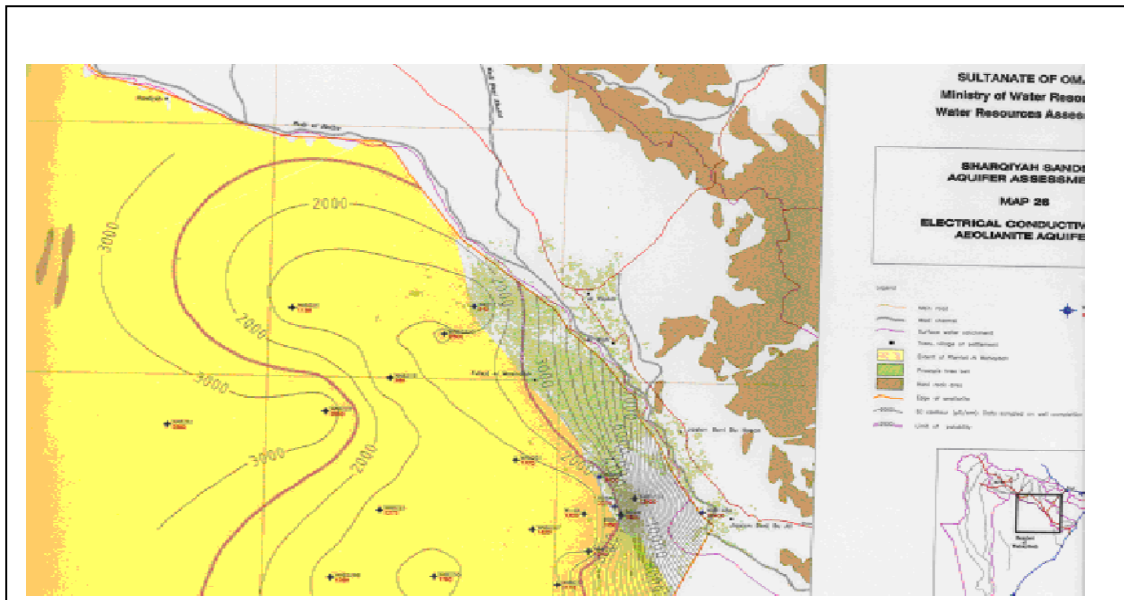

Figure 5: EC Distribution for Alluvial Aquifer

### **Aeolianite aquifer**

Sample locations and EC distributions are shown on Figure 6 below. The EC = 2,500  $\mu\text{m}/\text{cm}$  contour encloses a vast area of the north-eastern Sands area. The less common trace metals and phenols included within the Omani Standard have been executed at two sites, WAB234 and WAB237. The reference potability standard for all parameters is met by all samples collected from within the EC (-TDS) delimited area: all aeolianite aquifer groundwater within this area can thus be classified as potable.

### **Hydrogeological interpretation**

As a result of these intensive assessment works, two major aquifers have been identified in the study area: aeolianite and gravel alluvium. These are classified on the basis of modern replenishment as "active" (alluvial) and essentially "inactive" (aeolianite).

### **Alluvial aquifer**

The gravel aquifer, which has a thickness of 160m, lies within the upper horizon of the alluvium, which extends to depths of greater than 600m in a largely fault-bounded Basin. The upper part of the gravel alluvium contains the most transmissive gravel zones and potable water. The aquifer has been mapped over 1,653 km<sup>2</sup>.

The alluvial system receives primary recharge from bedrock seepage and infiltration of wadi flows. Throughflow has been determined to be 65 mm<sup>3</sup> per year, with major contributions emanating from Wadi Bani Khalid. Groundwater flow does occur from Wadi al Batha beneath the sands: transmission is facilitated by more permeable strata that offer preferential flow paths. Water use and water balance studies suggest that most, if not all, of the alluvial aquifer throughflow is consumed through agricultural development and the evapo-transpiration demand of the large natural woodland area that border the Sands.

Figure 6 . EC Distribution of Aeolianite Aquifer

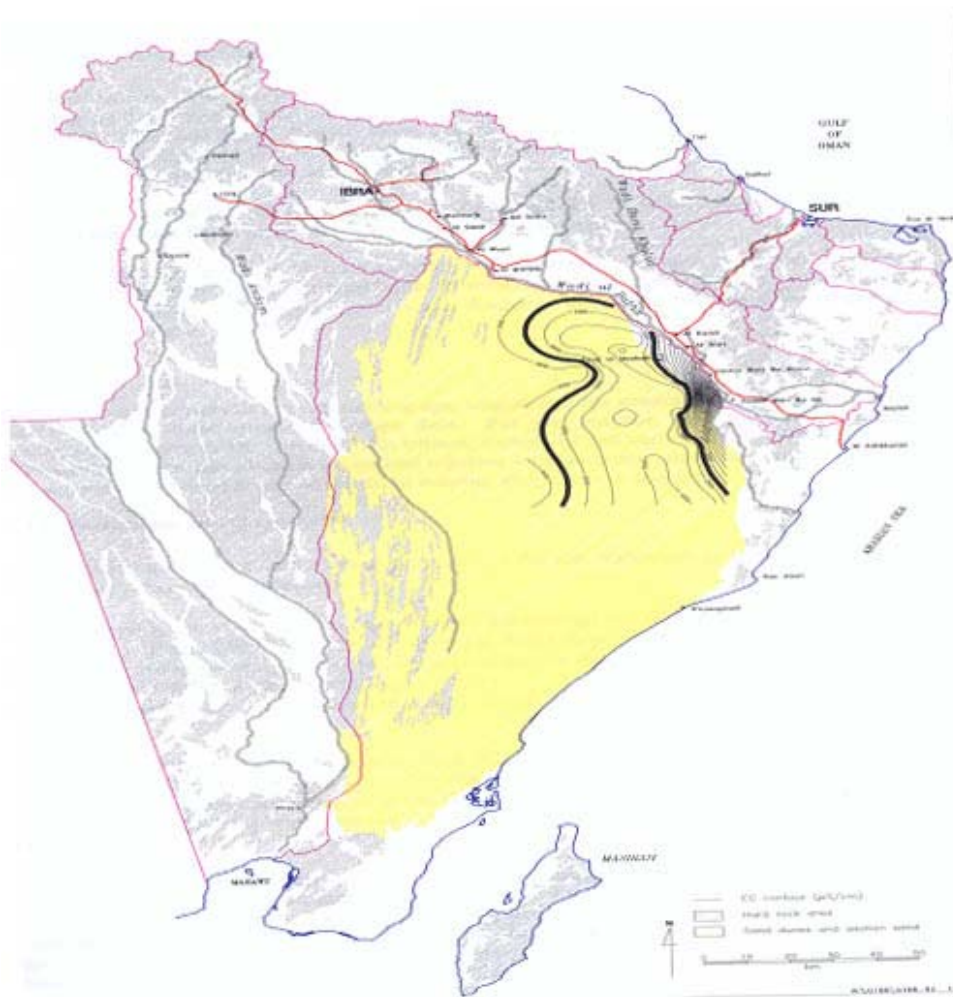

### **Aeolinite aquifer**

The aeolianite lies on top of the gravel alluvium locally attaining saturated thicknesses of 100m. Within the study area, the aquifer has been mapped over 1.529km<sup>2</sup>. Limited exploration work has confirmed major southward extension.

Recharge to the aeolianite appears limited to relatively minor amounts (three percent) of rainfall; throughflow, of the order 10 millions m<sup>3</sup>/year, occurs southeastward with discharge mainly to sabkhas. Most of the aeolianite water is "old" in that it has resulted from recharge during "water" periods, several thousands years ago. As such, the current aeolianite freshwater body appears as a remnant of a "fossil" freshwater "mound". Decay of the mound in recent arid periods has occurred through discharge at the perimeter of the Sands; the occurrence and extent of the natural prosopis woodland probably reflects this phenomenon.

The juxtaposition of "modern" and "fossil" systems creates a complex hydrogeological environment. Whilst the "active" system is now reasonably well understood, this is not the case for the aeolianite system. Uncertainties remain on boundaries, recharge processes and a number of water balance components.

Notwithstanding, significant volumes of potable groundwater storage have been firmly established. Freshwater thickness in excess of 100m (from the combined aquifer systems) extends over an area in the order of – 1,000 km<sup>2</sup>. Total groundwater storage has been estimated at 24,000 Mm<sup>3</sup> comprising 8,000 Mm<sup>3</sup> in the aeolianite. Assuming a 50 percent recovery factor, the total recoverable reserves are estimated to be around 12,000 Mm<sup>3</sup>.

## MAIN STAGES PRIOR OF THE PROJECT IMPLEMENTATION

### Pre-feasibility study

In 1996-97 a pre-feasibility study was carried out by MWR.

### Feasibility study

Based on results of the above study, a feasibility study was carried out and it was concluded that the project will provide highly needed water to the Wilayats of Al Kamil Wa Al Wafi, Jaalan bani bu Hasan and Jaalan Bani bu Ali.

### Engineering study

A consultancy services agreement was signed on the 5<sup>th</sup> of June 1999. The scope of work was to study the aforementioned program of exploration and pre-feasibility study, evaluate the results, provide different options for using the available water, to carry out an inventory of the private properties which could be affected by the project, design and prepare tender document for the construction of the Project, evaluate, and supervise construction of the Water Supply Scheme in the Ash' Sharqiyah Region. The design of services for the main water supply system was completed in October 2000 and the distribution system in February 2001.

### Modelling

A groundwater model was developed to simulate the effects of future development. The result showed that the implementation of the scheme would not have negative environment impacts on Aflaj or Prosopis trees, as the drawdown in these areas after 20 years will be less than one metre (Figure 7 below).

Figure 7 : Modelled drawdown in the project area

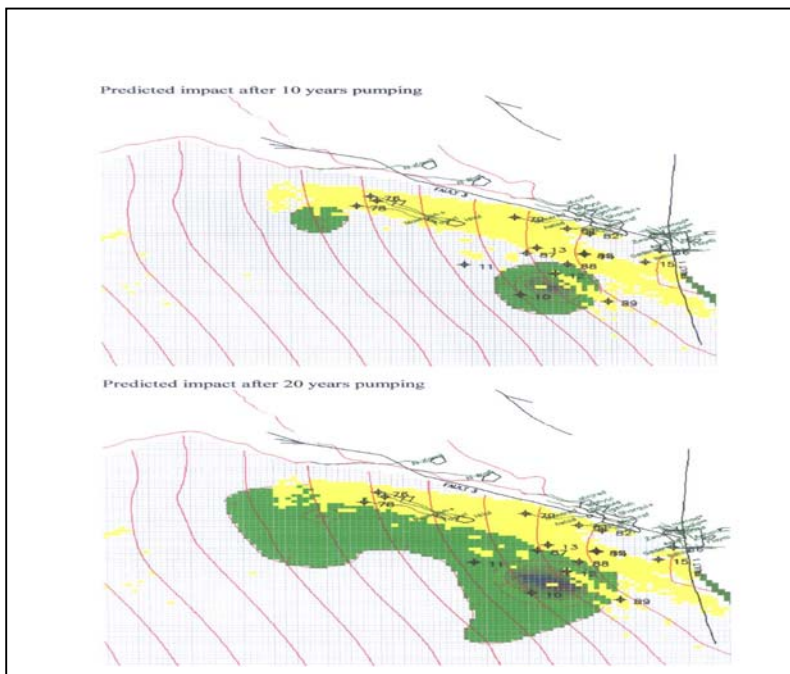

## THE PROJECT: ASH'SHAQIYAH SANDS WATER SUPPLY SCHEME

### Current water supply sources and usage

The number of residential buildings supplied with potable water in the Ash'Sharqiyah Region is 27,953, which represents 84.4 percent of the total number of buildings. Out of the total population of 195,077, 75.4 percent are provided with potable water. The water is provided to the buildings by tankers from "fixed tanker" points at every town. The residents also use *aflaj* for potable water, in addition to its use in the irrigation of agricultural lands. As well as the tanker points and *aflaj*, some private wells inside individual properties are used as non-potable water sources. The current average water consumption is 75 to 120 l/capita/day according to the socioeconomic study in the project area. The cost of water ranges from R.O.10 to 15/family/month. The water is distributed by privately owned water tankers.

### Population and water demand

Varying levels of water supply will be provided to the population (Figure 8) in the project area .

### Project components

Two well-fields were constructed. The northern well-field will supply the towns of Al Kamil and Al Wafi. The southern well-field will supply the Wilayats of Jaalan Bani Bu Hasan, Jaalan Bani Bu Ali. Smaller communities will be supplied by tankers from points in these towns or along the transmission lines. In the first phase, transmission pipelines, pump stations, storage reservoirs, power plants, water treatment facilities and production wells have been constructed (Figure 8 below).



Figure 8 : Main Components of the Scheme (Including Coastal Extension)

## PHASE 1 (MAIN WATER SUPPLY SYSTEM)

### **Al Kamil Wa Al Wafi Scheme**

- Drilling and development of 8 production wells, 10 monitoring wells, and installation of 4 km of collector pipes with a diameter ranging from 100 to 400mm.
- Construction of 1 ground reservoir with a capacity of 6, 000 m<sup>3</sup>
- Construction of 1 pumping station at the well field.
- Extension of the existing electricity supply grid to all sites of the project.
- Installation of 34 km of transmission mains (Ductile iron pipes) from the wellfield to the project towns and villages. The diameters ranges from 100 to 500 mm
- Construction of 3 water towers (capacity ranges from 500 to 1300 m<sup>3</sup>), and 1 water tank of 25 m<sup>3</sup> capacity.
- Construction of 3 tanker filling stations.
- The Construction of a work compound .The compound contains the administrative, control, operation, workshop, and maintenance facilities .
- Supply and installation of the SCADA system.
- Construction of fluoridation and chlorination facilities

### **Jaalan Bani bu Hasan and Jaalan Bani bu Ali Scheme**

- Drilling and development of 23 production wells, and installation of 4 km of collector pipes with a diameter ranging from 100 to 400mm
- Construction of 2 ground reservoirs. The first is located at the wellfield and has a storage capacity of 12300 m<sup>3</sup> capacity and the second is located near Al Ashkharah and has a capacity of 3330 m<sup>3</sup> and the second is located near Al Ashkharah and has a capacity of 3330m<sup>3</sup>.
- Construction of 1 pumping station at the wellfield.
- Extension of electricity supply grid to all sites of the project.
- Installation of 81 km of transmission mains (Ductile Iron Pipes) from the wellfield to the project towns and villages. The diameters range from 100 to 800 mm.
- Construction of 4 water towers of 1300m<sup>3</sup> capacity each and water tanks of 25-m<sup>3</sup> capacity.
- Construction of 8 tanker filling stations.
- Supply and Installation of the SCADA SYSTEM.
- Construction of fluoridation and chlorination facilities.



*Al Kamil Wa Al Wafi Scheme*

## PHASE 2 : DISTRIBUTION SYSTEM

The second phase of the project which was implemented in parallel to Phase I. It includes the supply and installation of 500 km of water distribution networks at the towns of Al Kamil wa Al Wafi, Jaalan Bani Bu Hasan, Jaalan Bani Bu Ali, Al Ashkharah and Falaj Al Mashaikh. The diameter of these pipes ranges from 100 to 400 mm. The work will also include valve chambers, fire hydrants, roads and wadi crossings.

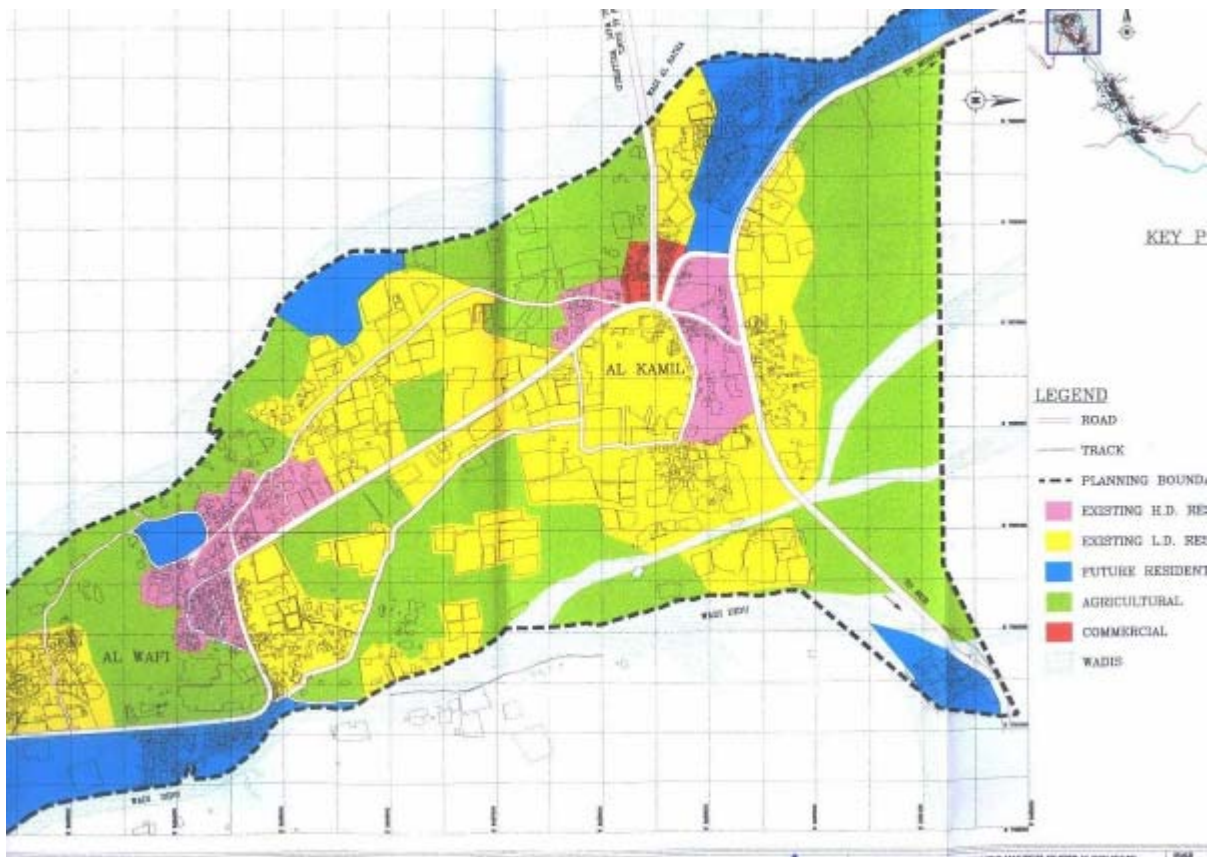

Figure 9: Al Kamil Wa Al Wafi Distribution System

### Extension to Coastal Area

In view of the deteriorating water situation in the coastal areas and the importance of water in the development of such areas, the Ministry has awarded the extension of this project to cover the towns of Al Sowaih, Al Bander Al Jadeed, Al Haddah, Ras Al Rowais, Al Khabbah, Al Daffah and Wadi Sal. A total of 54 km of pipes with a diameter ranging from 150 to 400 mm will be required. A ground reservoir of 5000 m<sup>3</sup> capacity and a pumping station in Asilah and 6 tanker filling reservoirs of 25 m<sup>3</sup> capacity will be constructed and equipped.

### Quantity and Quality Monitoring Control

The water supply system will be monitored and controlled by a state of the art instrumentation and control system which will accurately measure abstractions, flows and water quality at the production wells, pumping stations, transmission and distribution pipelines. In addition, a new system using pre-paid water credit cards will be installed at tanker points in order to control the selling of water and to minimise water losses.



The system will supply water at Omani standards for potable water and will be chlorinated and fluoridated to these required standards. Water quality will be regularly checked at an on-site laboratory and, in order to ensure continuity of supply in case of grid power failure, standby generators will automatically be brought into operation to operate well pumps and pumping stations.

### Wellfield Protection Zone

In order to protect Ash'Sharqiyah Sands Water Supply System Scheme from pollution and over abstraction, wellfield protection zones will be established, as indicated via differentiated colours in Figure 10 below:

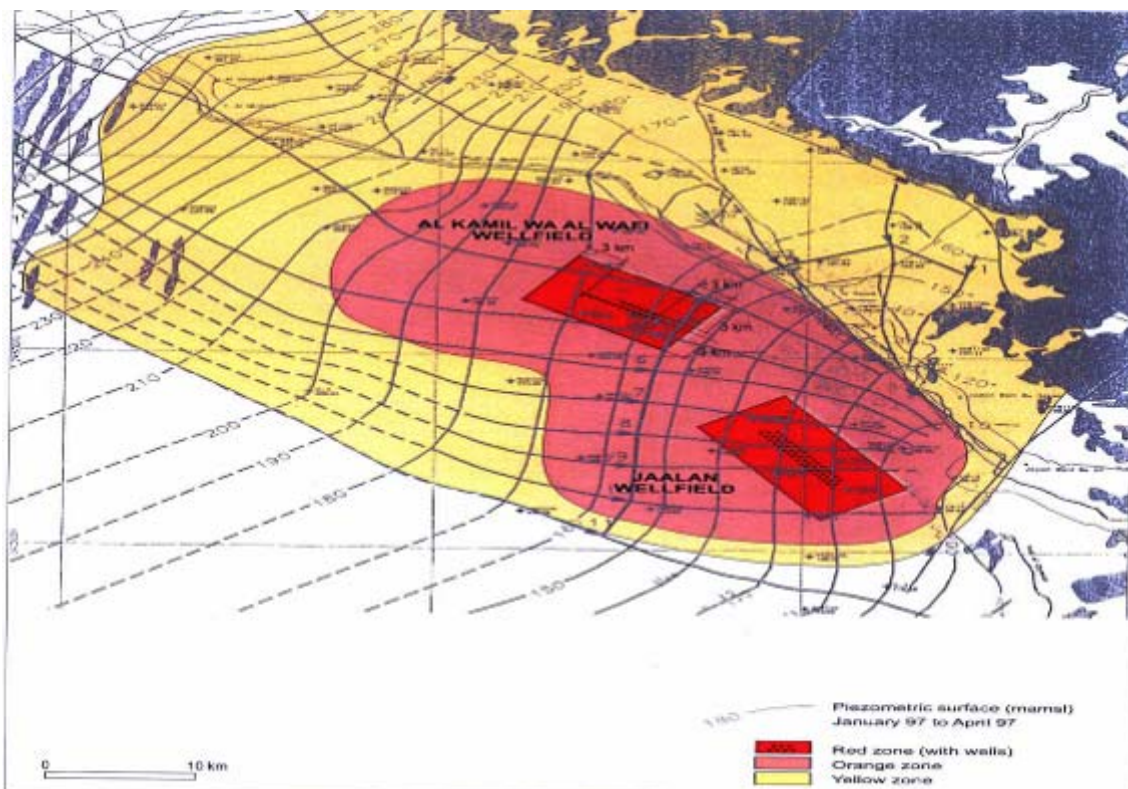

Figure 10 : Well field Protection Zones

**Red Zone:** In this zone there is a ban on the construction of new private wells as well as any pollution activity.

**Orange and Yellow Zones:** permitting and monitoring of all liquid waste discharge shall comply with mandatory treatment standards.

Other specific requirements for the three zones will be issued during the establishment of the protection zones.

### Environmental Study of the Project

In order to prevent any adverse impacts, especially to the Aflaj and Prosopis cineraria, an environmental impact assessment study of the project that included necessary technical specifications was conducted and as a result, 19 monitoring wells will be drilled to monitor water quality and levels. The project facilities such as water towers and the project administrative offices were designed so as to be suitable for the environment and heritage of Oman. In addition, a preliminary study was conducted on the state of the sewerage system in the area and its future requirements (Figure 11).

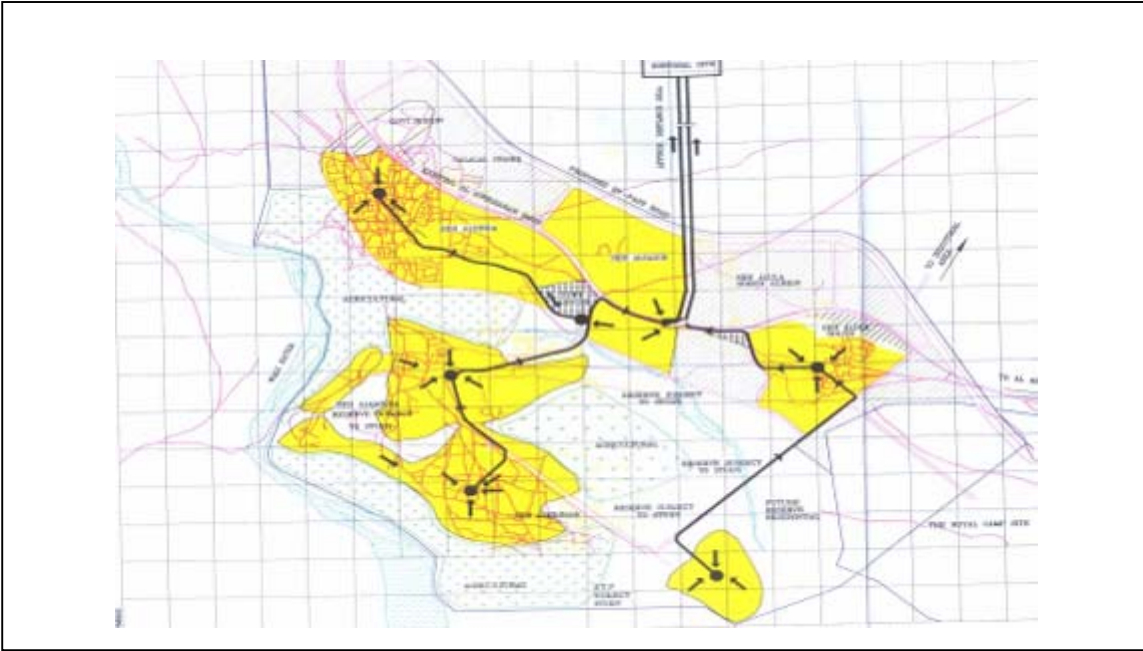

Figure 11: Concept of Wastewater Collection Scheme for Jaalan Bani Bu Ali

## CONCLUSION

This paper has explored how groundwater resources in aquifers beneath Ash'Sharqiyah Sands and the gravel plain north-east have been used to meet water shortages. The construction of Ash'Sharqiyah sands water supply scheme has enabled water supply to major towns - Al Kamil and Al Wafi, Falaj Al Mashaiekh, Jaalan bani Bu Hassan, Jalaan bani bu Ali, Al Ashkharah and Jaalan Bani Bu Ali – or approximately 79,000 people. This is an important achievement in the face of on-going water shortages, drought, increasing demands for water and other water-related problems in the region.



*Photos of Phase 1: Jaalan Bani bu Hasan and Jaalan Bani bu Ali Scheme*



*Photos of Phase 2: Water distribution*

# FAYOUM CITY SEWAGE TREATMENT PLANT, DEVELOPMENT STAGES, CASE STUDY

Ahmed El-Zayat, Environmental Engineering Group, Egypt  
Email: ahmed\_el\_zayat@yahoo.com

## Introduction

This case study focuses on three development stages of different types of processes utilized by the Fayoum city wastewater treatment plant in Egypt, in activated sludge biological wastewater treatment applications, namely: trickling filters, Sheffield aeration, and conventional processes. The three development stages have been evaluated, showing the design features, basis, parameters, and capacity. The performance analysis of each case is evaluated based on the experimental work and sampling analysis records for the influent characteristics and effluent quality. The assessment of each development process type is identified by the final effluent quality disposal to the drain with respect to the legal protection Law 48/82 and regulations of Egypt.

## FAYOUM CITY WASTEWATER TREATMENT PLANT DEVELOPMENT STAGES

### Fayoum City Old Wastewater Treatment Plant (A), 1936

The British established the Fayoum city old Wastewater treatment plant in 1936. The design flow was 200 l/s. The plant was located in the Kohafa area, 2.20 km east of the southeast edge of the city. The final effluent traveled 0.75 km east to be finally disposed of at the Al Bates Drain (Main Agriculture Drain in Fayoum). The effluent traveled from the Al Bates drain northwards and then west about 50 km where it entered the upper eastern end of Lake Quarun.

### Fayoum City Upgraded Wastewater Treatment Plant (B), 1986

In 1986 the plant was upgraded and rehabilitated, in order to improve the plant flow design capacity and its efficiency. The upgrading works were completed by extending vertically (increase the flow capacity) from 200 to 300 l/s (1,080 m<sup>3</sup>/hr).

### Fayoum City New Wastewater Treatment Plant (C), 1996

In order to increase the wastewater flow discharge of Fayoum city up to 70,000 m<sup>3</sup>/day in 1996, and to mitigate environmental violations caused by the upgraded plant (B) effluent; a new plant was established by NOPAWS. The construction of the new plant sought to meet the environmental regulations and capacity requirements for Fayoum city via horizontal extension of the plant design, reaching a total capacity 40,000 m<sup>3</sup>/day. This was implemented in two stages, with a flow capacity of 20,000 m<sup>3</sup>/day reached each day and then extended during the design extension, to reach a total flow 60,000 m<sup>3</sup>/day in the year 2000.

## FINAL EFFLUENT QUALITY AND PERFORMANCE EFFICIENCY

### Fayoum City Upgraded Old Plant (B) Performance Efficiency

The plant was upgraded to become a high-rate trickling filter plant, with a capacity of 300 l/s. While treatment efficiency of the trickling filters could be expected to decline somewhat under such higher hydraulic and corresponding organic loads, the overall treatment efficiency of the STP and its effluent quality should be better than those found in the results of sampling analysis. The final STP effluent quality (F-E) and treatment efficiency represent a combination of (F-P), (F-AS), and (F-TF). The STP effluent (F-E)

BOD<sub>5</sub> was 160mg/l, representing an overall treatment efficiency of 66.2 percent or an intermediate between primary and secondary treatment. Suspended solids concentration in the effluent was comparatively high at 104 mg/l due to the high influent suspended solids and the high percentage of primary effluent by-passed to the night tank. However, the percent removal of suspended solids at 51.7 percent proved disappointing, as it was significantly lower than the 85 percent removal of suspended solids from secondary treatment of because the final clarifiers were not constructed.

### **Fayoum City New STP (C) Performance Efficiency**

The final effluent quality of plant (C) is yielding impressive results; as they are comply with standard limits of Law 48/1982. The implementation of a conventional single-stage activated sludge process in the new wastewater treatment plant was successful and has no negative impacts on the environment, when taking into consideration that the plant capacity is running at a capacity of 695 l/s.

## **CONCLUSION**

The different development stages of the Fayoum City Wastewater treatment plant are as follows: (A) Old Plant, (B) Upgraded Plant, and (C) New Plant, each showing plant performance and unit treatment process efficiency for the different process trains. The effluent quality impact of the Fayoum City Old Upgraded Plant is not in compliance with the standards limits of the Ministry of Irrigation and Water Resources under Law No. 48/1982 due to lack of final settling tanks and the other operational problems. The final effluent quality of the Fayoum City New Plant (C) is giving impressive results, which in compliance with the standard limits of the Ministry of Irrigation and Water Resources Law No. 48/1982.

The implementation of a conventional single-activated sludge biological treatment process has no significant impacts on agricultural drains, water bodies and other aspects of the surrounding environment. It will be obvious that the activated sludge process, when compared to plants employing biological filter beds, provides a method of treatment which is capable of effecting considerable economic gains. It must be stressed that all claims and comparisons are substantiated by results obtained under actual plant working conditions over a period of years, as the method and the equipment have already proved successful in a variety of applications.

The major advantages of an activated sludge treatment plant are therefore self-evident in a variety of ways:

- In economic terms, by reducing the total ground area requirement.
- In practical terms, by simplifying construction and management through the use of vertical-shaft aerators which can be used in deeper channel and present a more compact arrangement.
- In terms of quality, the activated sludge system readily achieves a 20:20 BOD/SS, standard.

## **CASE STUDY: FAYOUM CITY WASTEWATER TREATMENT PLANT DEVELOPMENT STAGES**

### **Fayoum City Old Wastewater Treatment Plant (A), 1936**

The British established the Fayoum city old Wastewater treatment plant, in 1936. It is located at Kohafa area, approximately 2 km east of the southeast edge of the Fayoum city. The final effluent, after traveling approximately 0.5 km east, enters the Al Bates Drain (main agriculture drain in Fayoum). From this point of entry, the effluent travels north from the Al Bates Drain and then west, for a total of about 50 km, where it enters the upper eastern end of the Lake Quarun (see Figure 1).

Figure 1: Fayoum City Wastewater Treatment Plant Location Plan

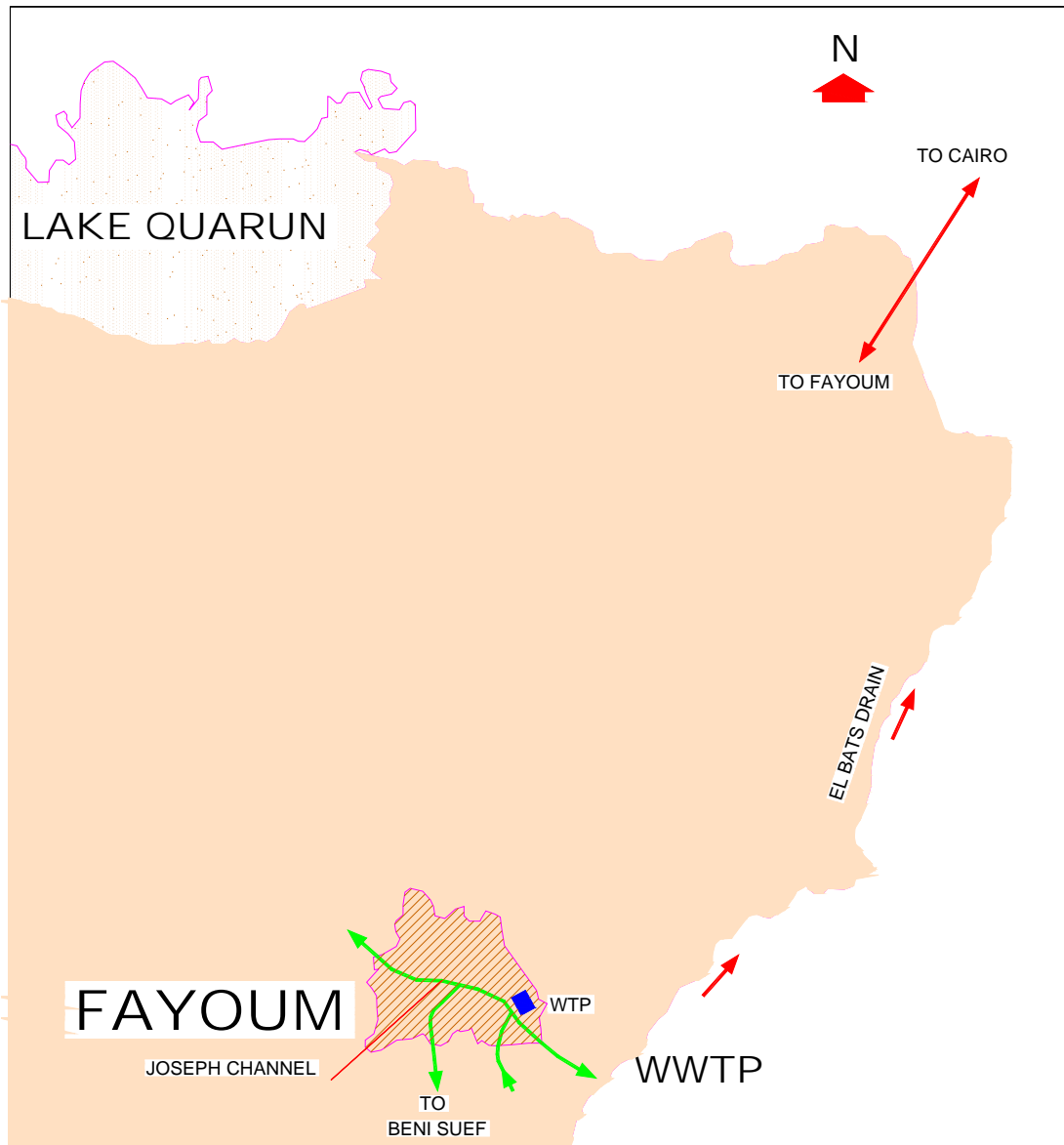

**Description of unit processes**

The plant was designed for capacity 200 l/s (17,280 m<sup>3</sup>/d), with the intention to serve until 1956. The biological process contains two types of treatment streams: one stream is a trickling filter, and the other stream is working as an activated sludge process or oxidation ditches (Sheffield aeration tanks). The process flow diagram and plan view layout are shown in Figures 2 and 3 below.

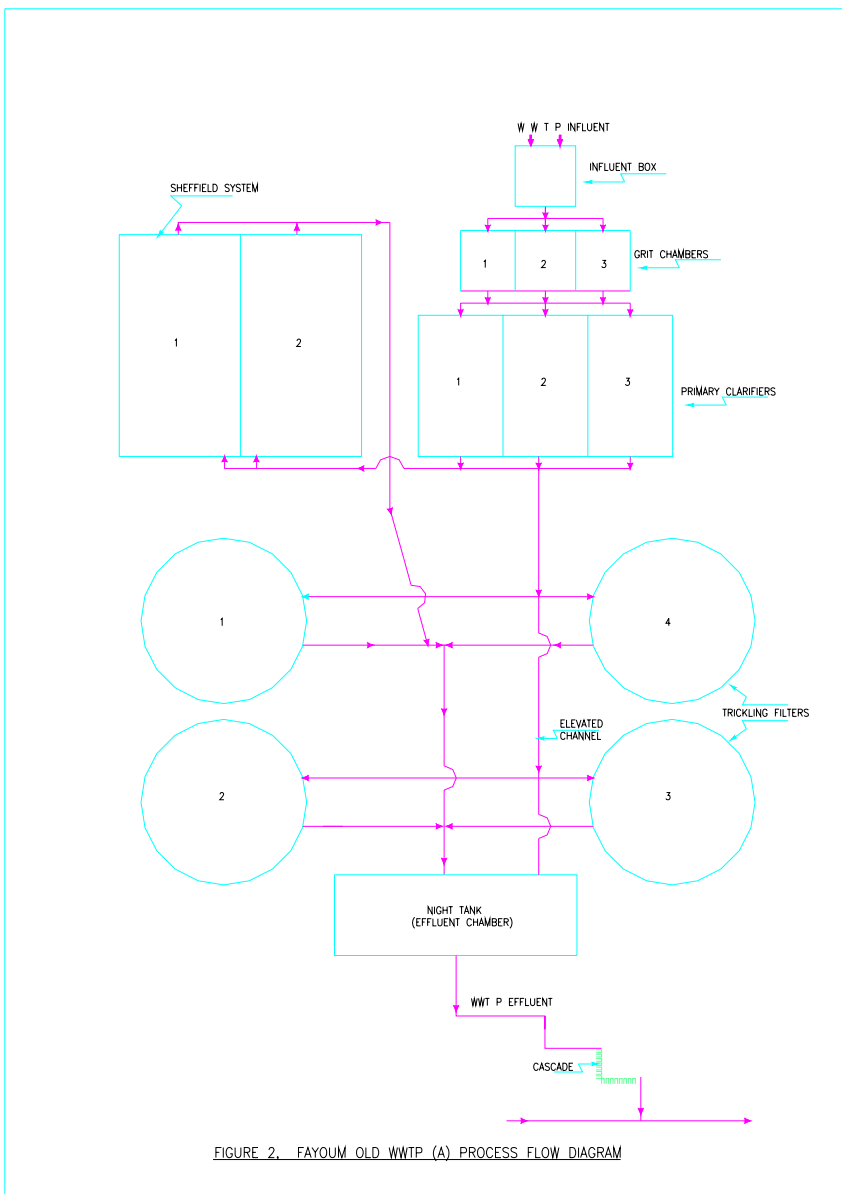

### Preliminary and primary treatment units

The Inlet chamber receives the influent from the force mains where the manual screens are located. It is then distributed into three grit chambers and collected in the outlet channel before being finally distributed to three primary sedimentation tanks (Lybzeying type).

### Biological treatment units

The biological treatment units are divided into two streams. The first stream flows to the trickling filters followed by the night storage tank (it was used for water storage in the night hours to irrigate the surrounding agriculture land in the mooring hours according to original design, but now is drained to Al-Bates drain). The second stream flows to the aeration tanks (Sheffield type) followed by final sedimentation zones (Dortomond type). The activated sludge is returned by sludge pumps to the inlet of the aeration tank to be mixed with the raw wastewater.

### Sludge drying beds

The primary sludge is received from the primary sedimentation tanks, scum, floating matter, whereas secondary waste/ surplus sludge is received from final sedimentation zones.

Figure 3: Old Wastewater Treatment Plant Layout

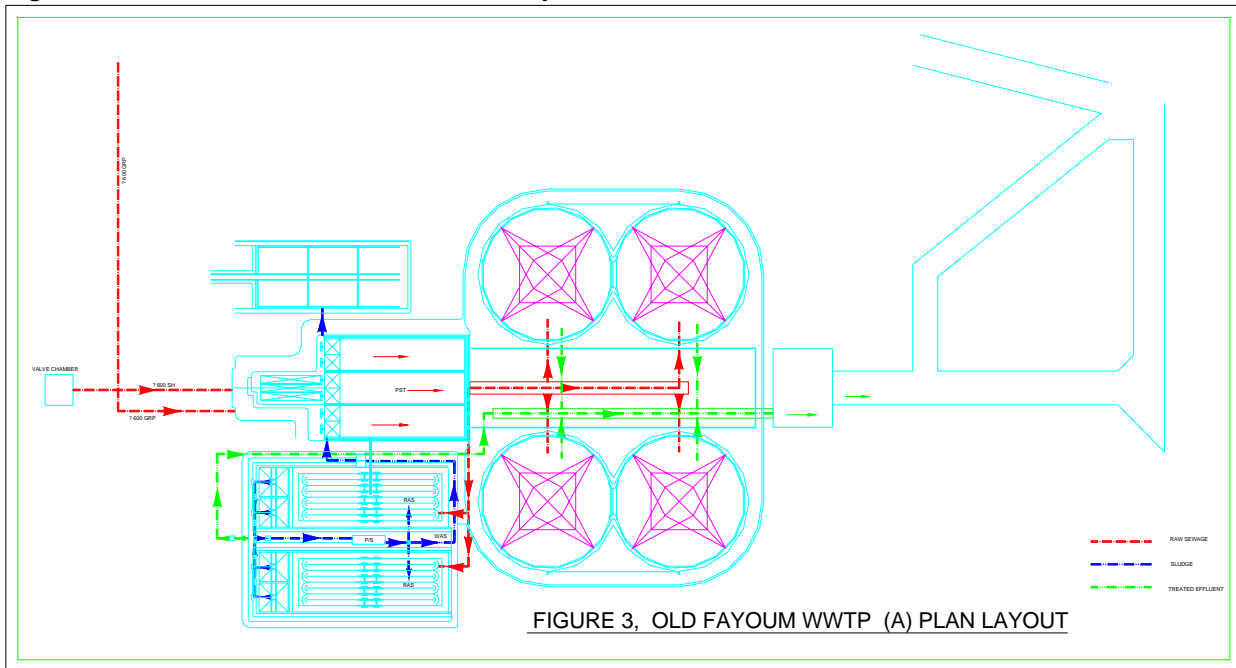

### FAYOUM CITY UPGRADED OLD WASTEWATER TREATMENT PLANT (B), 1986

In 1986 the Fayoum city old wastewater treatment plant was upgraded and rehabilitated in order to improve the plant capacity and efficiency. The upgrading work was done vertically (increasing the flow capacity) from 200 up to 300 l/s (25,920 m<sup>3</sup>/day). This process is explained in more detail in the following sections.

#### Upgrading and modification works

##### Primary Treatment Units

*a. Inlet Chamber*

Construction of a new inlet chamber with new screens to sustain a maximum design flow capacity of 500 l/sec. The new inlet chamber was connected to the old inlet chamber via a channel.

*b. Measuring Discharge Weir*

Construction of a new measuring weir at the old inlet chamber.

*c. Grit Chamber*

Construction of new splitter baffles for equal flow distribution to the three grit chambers with installation of new penstocks for flow control.

*d. Primary Sedimentation Tanks “Lybzeying”*

Adapting primary sedimentation tanks outlet weir to sustain a maximum flow 500 l/s.

##### Biological / Secondary Treatment Units

*a. Biological Trickling Gravel Filters*

Upgrading the standard-rate system to a high-rate system by recirculation of final sedimentation zones effluent to inlet of the trickling filters (for dilution of the inlet organic load concentration) and replacing the filter gravel media and the feeding inlet pipes.

*b. Recirculated Wastewater Pumps for the High-Rate Trickling Filters*

Recirculation of the final sedimentation zones effluent to the biological gravel trickling filters by installing two new pumps ( $Q= 150 \text{ l/sec}$ ,  $H_m= 10 \text{ m}$ ).

*c. Trickling Filters Effluent Channel*

Elevation of effluent channel sides to divert the trickling filters' effluent from the night storage tank and installation of a new 16 inch pipe which is connected to the recirculation sump.

*d. Sheffield Aeration Tanks followed by Final Sedimentation Zones "Dortomond"*

Rehabilitation of the influent distribution weir, replacement of the return activated sludge pumps with new pumps, and rehabilitation of the final sedimentation zones "Dortomond".

*e. Implementation of the Final Clarifiers*

The construction of the new final clarifiers was not implemented due to a lack of the construction project budget, which is still affecting the plant's effluent quality.

**Disinfection works**

Installation of a new disinfecting chlorinating system, featuring a rectangular contact tank, with outlet discharge measuring weir.

**Post-aeration by cascade**

Construction of a new cascade for post-aeration of the final effluent before chlorination, the cascade is 9 m high and consists of three steps, each three meters high and 20 meters wide.

**Sludge treatment**

*a. Thickeners*

Construction of new circular tanks 10m in diameter and 4.2m deep for sludge thickening and construction of a new sump to collect primary sludge.

*b. Drying Sludge Beds*

Construction of 105 new drying beds, with an under-drain system with submersible pumps. Removal of the existing earth beds by construction of new concrete bottom beds.

**FAYOUM CITY NEW WASTEWATER TREATMENT PLANT (C), 1996**

Due to the increment in the wastewater flow discharge of the Fayoum city ( $70,000 \text{ m}^3/\text{day}$ ) and due to the environmental violation from the upgraded plant (B) effluent quality, a new plant was established in 1996. The aim was to satisfy the environmental and capacity requirements for Fayoum city as by horizontally extending the plant to a total design capacity of  $40,000 \text{ m}^3/\text{day}$ . This was implemented in two stages, each stage comprising a  $20,000 \text{ m}^3/\text{day}$  capacity, and was eventually extended to a maximum flow capacity of  $60,000 \text{ m}^3/\text{day}$  in the year 2000.

**Description of unit processes**

The process flow diagram and plan-view layout are shown in Figures 4 and 5 (below).

**Preliminary Treatment Units**

*a. Deceleration Chamber*

Reinforced concrete chamber 5.50 m depth.

*b. Inlet Deceleration Chamber*

The chamber receives the influent, returned sludge, thickeners supernatant, and drained water from the drying beds.

*c. Mechanical Screens*

Four mechanical screens 1.5 m wide with self-cleansing operation every 15 minutes.



#### *d. Oil, Grease and Grit Removal Chambers*

Pre-aeration occurs in the grit chambers by air injection via nozzles at 2m deep for oil and grease flotation which will be skimmed.

### **Primary treatment units**

#### *a. Main Primary Splitter*

A circular chamber receives the effluent from the grit chambers for distribution into three streams, each with a 20,000 m<sup>3</sup>/day capacity, to three sub-primary splitters. The main primary splitter contains a by-pass line to the Al-Bates drain in case of emergencies.

#### *b. Sub-Primary Splitter*

Three circular tanks each receive effluent from the main primary splitter, which is then distributed into two primary sedimentation tanks.

#### *c. Primary Sedimentation Tanks*

For each stream, two circular tanks receive the effluent from the primary sub-splitter, each with a one hour detention time. The excess or waste sludge from the final sedimentation tank is returned from the WAS pumping station into the sub-splitter to enhance the flocculation process in the primary sedimentation tanks.

### **Secondary biological treatment**

#### *a. Surface Aeration Tanks "Simplex"*

The primary sedimentation tanks effluent is collected in a channel, and then flows to the aeration tanks which includes surface aerators fixed with a vortex stopper (X-shape) at bottom of each aeration tank. The Return Activated Sludge from the final clarifiers is lifted by screw pumps to be mixed with primary sedimentation tanks effluent (MLSS 4000 ppm, aeration detention time is 6 hrs).

#### *b. Final Effluent Splitter*

A circular tank for splitting the aeration tanks effluent into four final sedimentation tanks.

#### *c. Final Sedimentation tanks*

Four circular tanks for each stream (detention time is two hours). Using a scraper, the secondary sludge is collected in a sludge hopper and then drawoff goes into the RAS screw pumps sump.

### **Disinfecting tanks**

Two rectangular tanks receive the effluent from final clarifiers for disinfection (contact time is 30 minutes with a chlorine dose 15 ppm).

### **Sludge treatment units**

#### *a. Thickeners*

Two circular tanks receive excess sludge from the main sludge sump. The sludge is thickened and supernatant is flow out.

#### *b. Drying Beds*

The thickened sludge flows to the drying beds every 12 hours and the drained water flows to a drainage sump to be lifted to the inlet chamber.

### **RAS Screw Lifting and WAS pumping Station**

It receives RAS from the final clarifiers and is lifted via two screw pumps to the aeration tanks according to the required MLSS ratio (4 g/l). Waste sludge is pumped by two submersible pumps to the main primary splitter for co-settling with the primary sludge.

## Main Sludge Sump

It receives the scum and primary sludge from primary sedimentation tanks. The scum is collected in the main scum sump and pumped via submersible pumps to the thickeners.

## Main Scum Sump

When industrial waste is intruded with the raw wastewater, the scum is not pumped to the main sludge sump, but will be treated separately.

## Supernatant Pumping Station

It receives supernatant from the thickeners, and the drained water from the drying beds is then pumped to the inlet chamber.

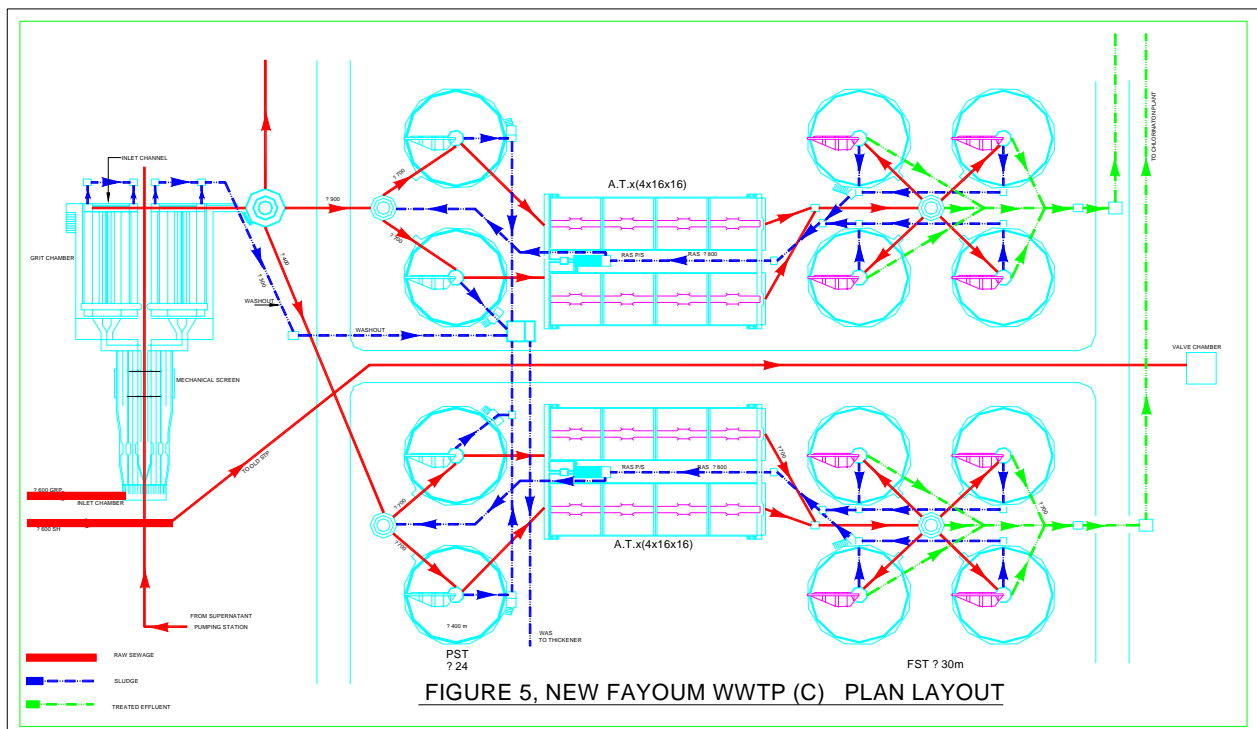
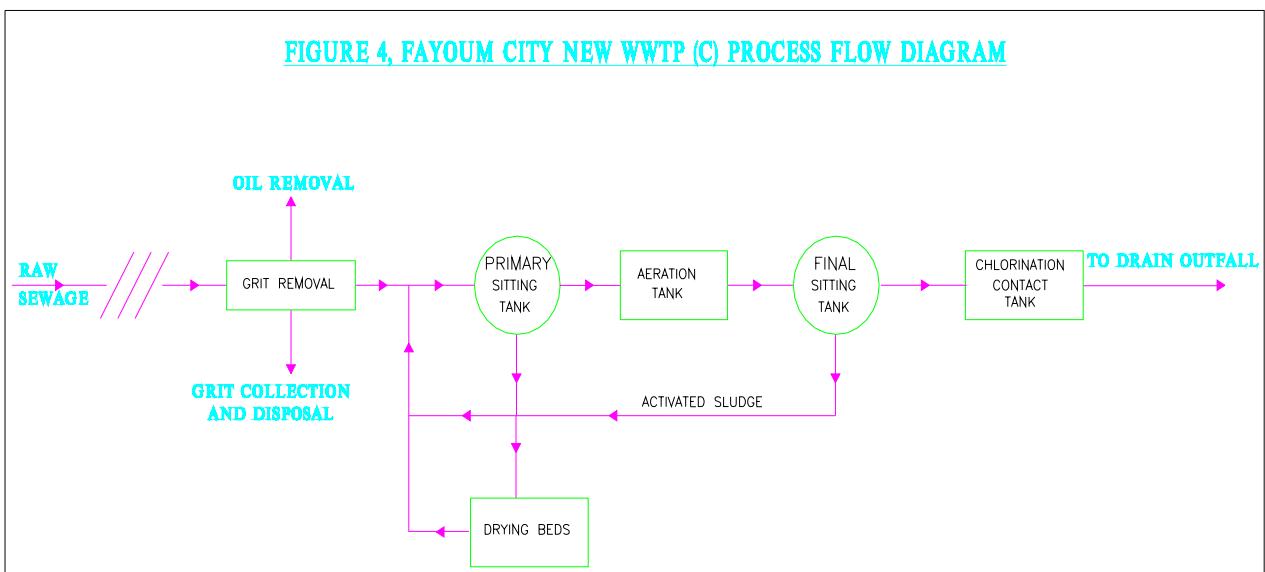

## **EXPERIMENTAL WORKS**

### **Fayoum Old WWTP (A) Performance Evaluations**

The sampling stations and flow points are shown in Figure 6 below. Records of sampling analysis results are obtained from the plant history and are presented in Figure 7 below. The flow measured was 330 l/s. The process treatment percentage removal efficiency is presented in Figure 8. The Fayoum Old WWTP was more than a primary treatment plant in that it contains several secondary unit treatment processes including a dual activated sludge or oxidation ditch unit as well as four large, single-stage, standard-rate trickling filters. However, it lacks final clarifiers and chlorination facilities. Therefore, the plant was capable only of providing treatment intermediate between primary and secondary at that time.

### **Fayoum City Upgraded Old WWTP (B) Performance Evaluation**

The flow measured was 330 l/s and experimental work done in order to evaluate the implemented modifications (upgrading) works for the Fayoum Upgraded WWTP (B) as presented in figures 9 and 10. The plant was upgraded for a capacity 300 l/s as a high-rate trickling filter plant. Therefore, it appears that it should be possible to pass all the flow up to 300 l/s through the trickling filters. While treatment efficiency of the trickling filters can be expected to decline somewhat under such higher hydraulic and corresponding organic loads, the overall treatment efficiency of the STP and its effluent quality should be better than those found in the results of sampling analysis. The final STP effluent quality (F-E) and treatment efficiency represent a combination of (F-P), (F-AS), and (F-TF). The STP effluent (F-E) BOD<sub>5</sub> was 160 mg/L, representing an overall treatment efficiency of 66.2 percent, or constituting an intermediate between primary and secondary treatment. Suspended solids concentration in the effluent was comparatively high at 104 mg/l due to the high influent suspended solids and the high percentage of primary effluent by-passed to the night tank. However, the percent removal of suspended solids was disappointing at 51.7 percent, a figure much lower than secondary treatment of 85 percent, because the final clarifiers were not implemented.

### **Fayoum City New WWTP (C) Performance Evaluation**

The flow measured was 685 l/s and the results of average yearly sampling experimental work were done in order to evaluate the Fayoum New WWTP (C), as presented in Figures 11 and 12. The final effluent quality of the Fayoum City New Plant (C) yielded impressive results, in compliance with the standards limits of the Ministry of Irrigation and Water Resources under Law No. 48/1982.

### **Fayoum City Wastewater Effluent Quality Impact Assessment**

The water quality impact analysis of the wastewater flow from the Fayoum Upgraded WWTP (B) and New WWTP (C) on the receiving water bodies, Al Bates Main Agricultural Drain and, in turn on Lake Quarun was performed under the actual treatment levels. These data, in turn, were compared with the standard limits of the Ministry of Irrigation under Public Law 48, as shown Figures 13 and 14 below.

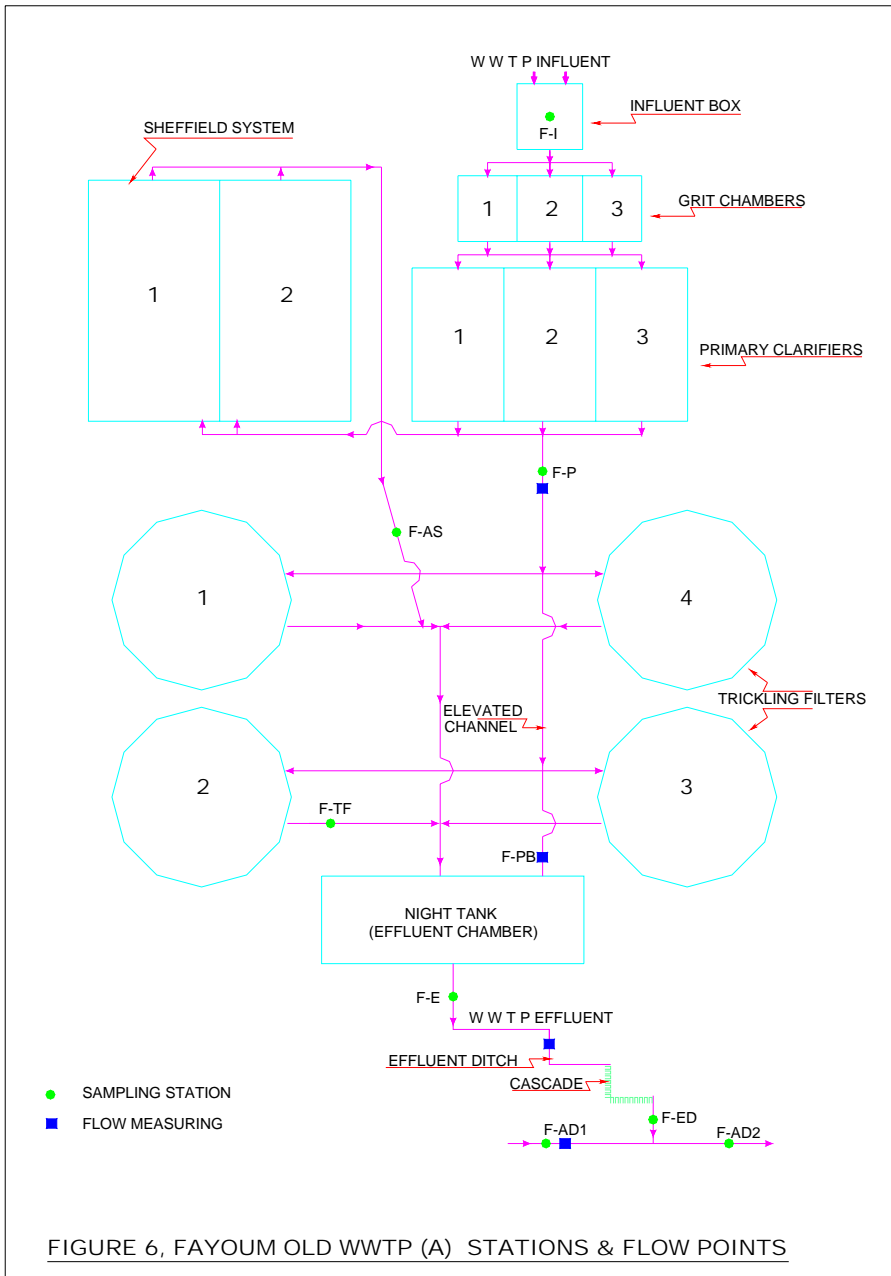
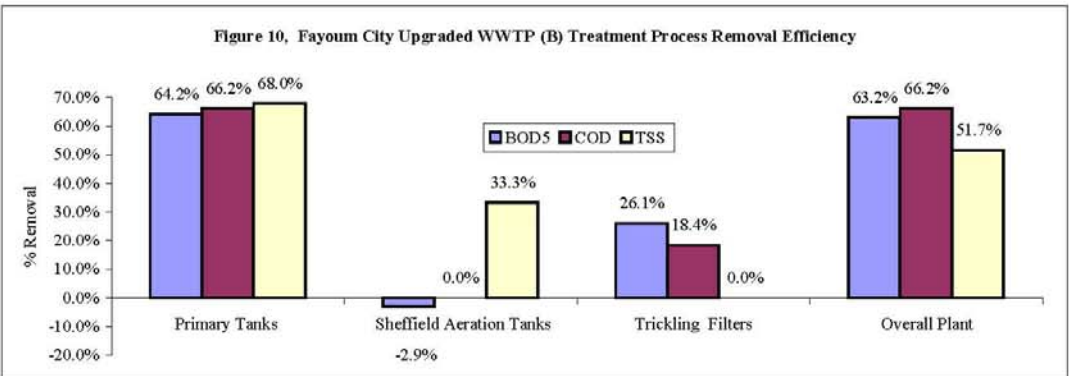
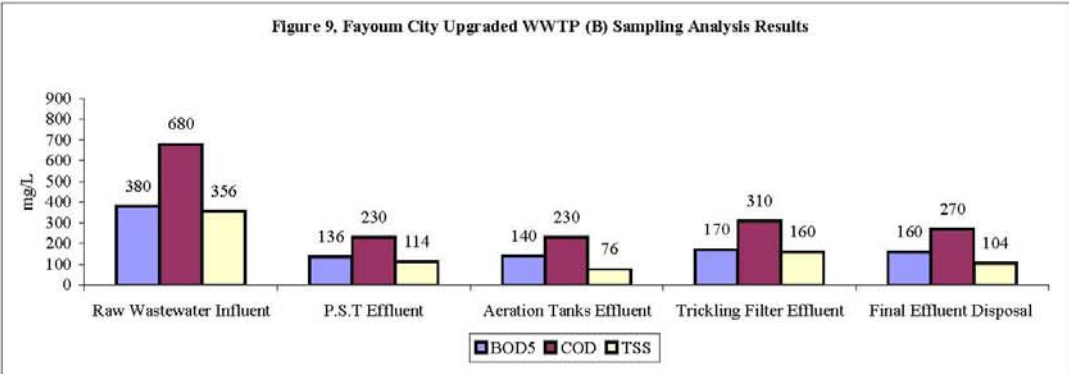
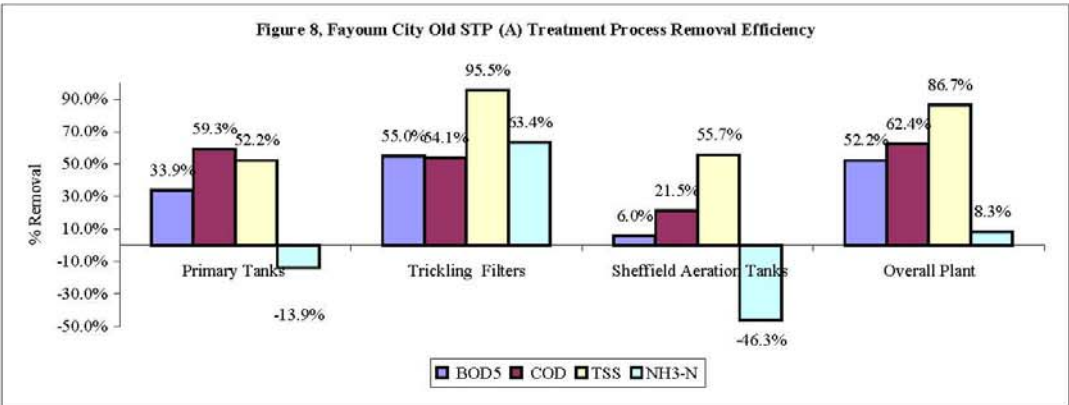
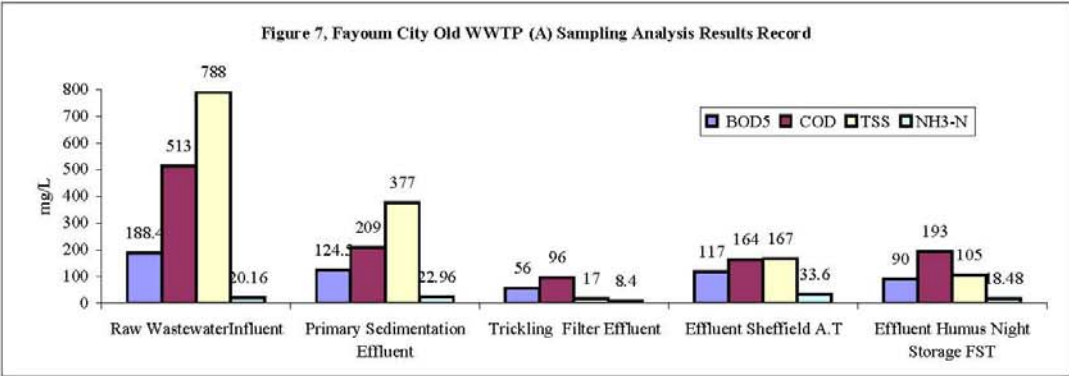

FIGURE 6, FAYOUM OLD WWTP (A) STATIONS & FLOW POINTS



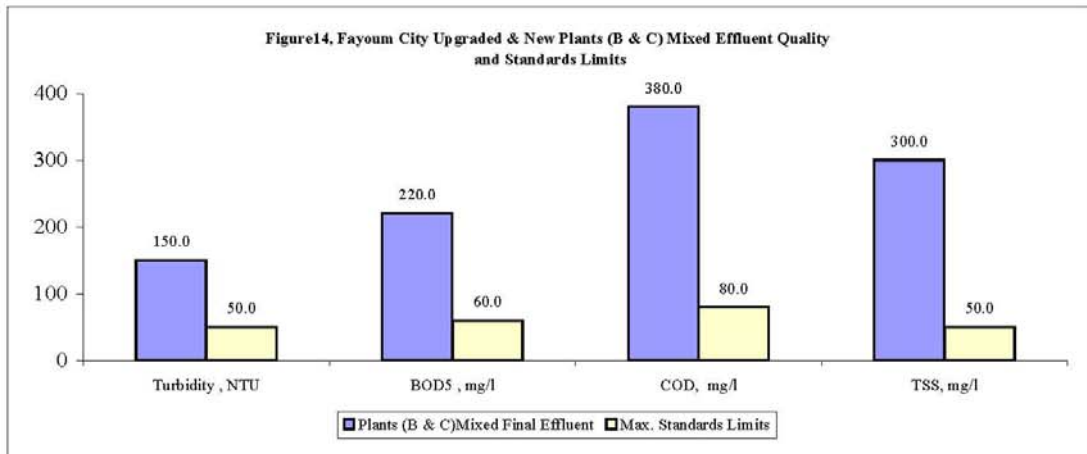
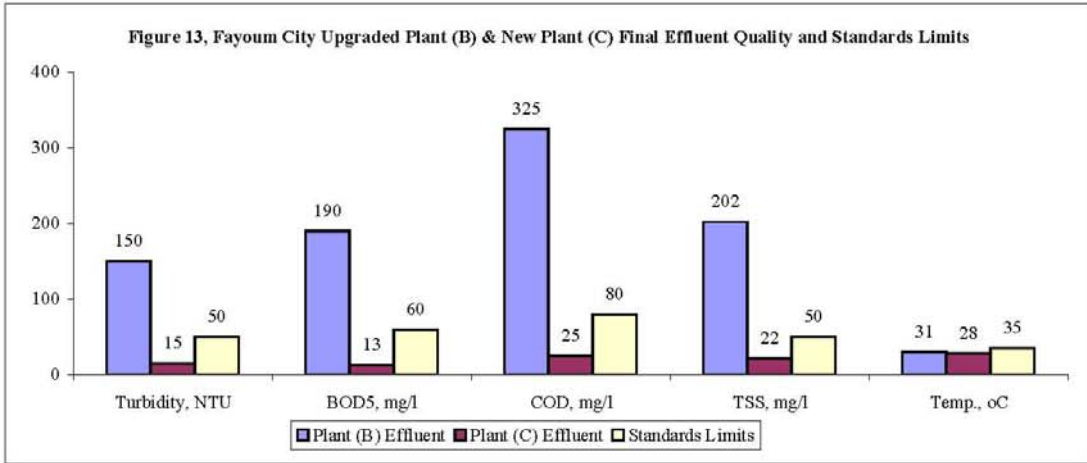
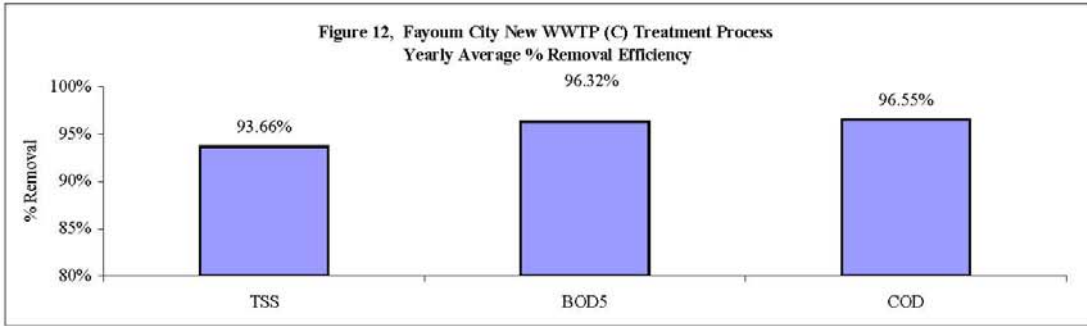
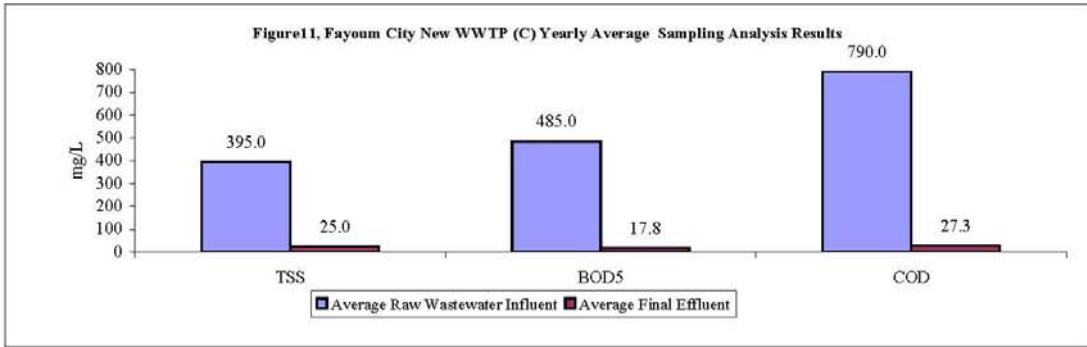

Table (1) Summary of the Fayoum City WWTP Development Stages

#	ITEM	FAYOUM WWTP
1.	Old System	
1.1	Commissioning Year	1936
1.2	Type of System	Trickling Filter + Sheffield Aeration Tanks
1.3	Type of Process	Attached Growth + Suspended Growth, Complete Mix Conventional Activated Sludge
1.4	Process Train	Sc + GRC + PST + TF + HNT + SAT + FST
1.5	A.D.F, m <sup>3</sup> /day	17,280
2.	Upgraded System	
2.1	Upgrading Year	1986
2.2	Type of System	Trickling Filter + Sheffield Aeration Tanks
2.3	Type of Process	Attached Growth + Suspended Growth, Complete Mix Conventional Activated Sludge
2.4	Process Train	Sc + GRC + PST + TF + HNT + SAT + FST
2.5	Type Of Upgrading	Vertical Upgrading
2.6	ADF, m <sup>3</sup> /day	25,920
3.	New Developed System	
3.1	Development Year	1996
3.2	Type of System	Conventional Aeration Tank
3.3	Type of Process	Suspended Growth, Complete Mix Conventional Activated Sludge
3.4	Process Train	Sc + GRC + PST + AT + FST + CT
3.5	Type of Upgrading	Horizontal Extension
3.6	ADF, m <sup>3</sup> /day	60,000
3.7	Aeration Tanks Detention Time, hrs	6
4.	New Plant (C) Raw Influent Characteristics / Secondary Effluent Quality (% Removal)	
4.1	BOD <sub>5</sub> , mg/L	485 / 17.8 (96.33%)
4.2	TSS, mg/L	395 / 25 (94%)
4.3	COD, mg/L	790 / 27.3 (97%)
4.4	DO	0.2 / 4.9
4.5	pH	7 / 7.54
4.6	Average Temp. °C	25
5.	Final Effluent Disposal Outfall	Al Bates Agricultural Drain Discharge to Lake Quarun
6.	Sludge Disposal	Drying Beds
7.	Surrounding Environment	Agricultural Areas

Sc (Screens), GRC (Grit Removal Chamber), PST (Primary Sedimentation Tanks), TF (Trickling Filters), HNT (Humus Night Tank), SAT (Sheffield Aeration Tanks), FST (Final Settling Tanks), CT (Contact Tank).

## CONCLUSION

The different development stages of the Fayoum City Wastewater treatment plants are summarized in Table 1: (A) Old Plant, (B) Upgraded Plant, and (C) New Plant, showing the performance and unit treatment process for different process trains. The effluent quality impact of the Fayoum City Upgraded Old Plant is not in compliance with the standard limits of the Ministry of Irrigation and Water Resources under Law No. 48/1982, due to the lack of final settling tanks and the other operational problems. The final effluent quality of the Fayoum City New Plant (C) has yielded impressive results, which comply with the standard limits of the Ministry of Irrigation and Water Resources under Law No. 48/1982.

The implementation of a conventional single-stage activated sludge biological treatment process has no significant impacts on the surrounding environment like agricultural drains and water bodies. It will be obvious that the activated sludge process relative to plants employing biological filter beds provides a method of treatment that is capable of achieving considerable economic gains.

It must be stressed that all claims and comparisons are substantiated by the results obtained under actual plant working conditions over a period of some years. Thus it can be said that the method and the equipment have already proved successful in a variety of applications.

The major advantages of an activated sludge treatment plant are self-evident in a number of different ways:

- In economic terms, by reducing the total ground area requirement.
- In practical terms, construction and management are simpler. The use of vertical-shaft aerators allows operation in a deeper channel and presents a more compact arrangement.
- In terms of quality, the activated sludge system readily achieves a 20:20 BOD/SS, standard.